

**TECHNICAL MANUAL
OPERATOR'S, UNIT AND
DIRECT SUPPORT
MAINTENANCE MANUAL INCLUDING
REPAIR PARTS AND SPECIAL TOOLS
LIST**

**MODULAR PRINTING
SYSTEM,
MODULE B
PRESS SECTION**

(NSN 3610-01-283-4582)

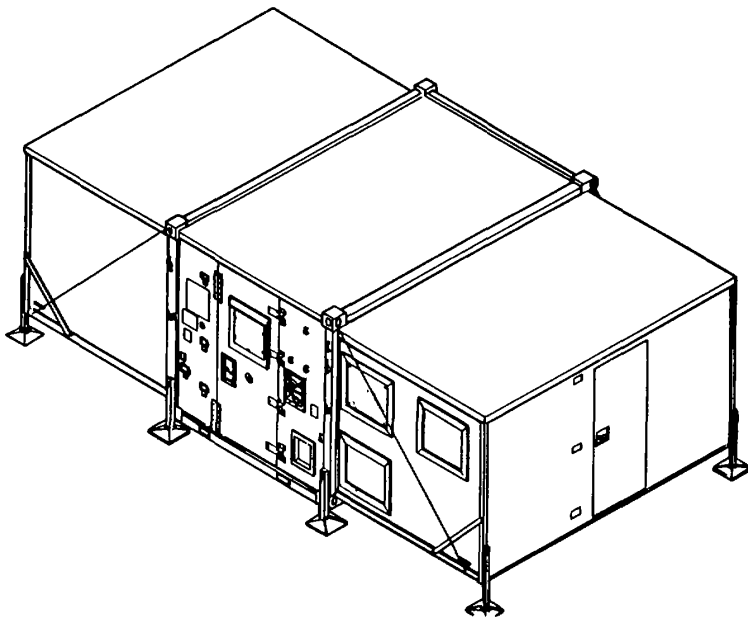

Approved for public release; distribution is unlimited.

INTRODUCTION	1-1
OPERATING INSTRUCTIONS	2-1
OPERATOR MAINTENANCE	3-1
UNIT MAINTENANCE	4-1
DIRECT SUPPORT MAINTENANCE	5-1
REFERENCES	A-1
MAINTENANCE ALLOCATION CHART	B-1
COMPONENTS OF END ITEM AND BASIC ISSUE ITEMS LIST	C-1
ADDITIONAL AUTHORIZED LIST ITEMS	D-1
EXPENDABLE/DURABLE SUPPLIES AND MATERIALS LIST	E-1
REPAIR PARTS AND SPECIAL TOOLS LIST	F-1
ILLUSTRATED LIST OF MANUFACTURED ITEMS	G-1

CHANGE
NO. 2

HEADQUARTERS
DEPARTMENT OF THE ARMY
WASHINGTON, D.C., 31 OCTOBER 1994

OPERATOR'S, UNIT AND DIRECT SUPPORT
MAINTENANCE MANUAL
INCLUDING REPAIR PARTS AND SPECIAL TOOLS LIST
MODULAR PRINTING SYSTEM, MODULE B, PRESS SECTION
(NSN 3610-01-283-4582)

DISTRIBUTION STATEMENT A: Approved for public release; distribution is unlimited.

TM 5-3610-293-13&P, 22 August 1990, is changed as follows:

1. Remove and insert pages as indicated below. New or changed text material is indicated by a vertical bar in the margin. An illustration change is indicated by a miniature pointing hand.

Remove pages

i and ii
1-1 and 1-2
C-9 and C-10

Insert pages

i and ii
1-1 and 1-2
C-9 and C-10

2. Retain this sheet in front of manual for reference purposes.

By Order of the Secretary of the Army:

Official:

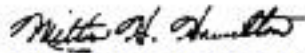

MILTON H. HAMILTON
*Administrative Assistant to the
Secretary of the Army*
07603

GORDON R. SULLIVAN
General, United States Army
Chief of Staff

DISTRIBUTION:

To be distributed in accordance with DA Form 12-25-E, block no. 5533, requirements for TM 5-3610-293-13&P.

CHANGE

NO. 1

HEADQUARTERS
DEPARTMENT OF THE ARMY
WASHINGTON, D.C., 27 APRIL 1992

Operator's, Unit and Direct Support Maintenance Manual
(Including Repair Parts and Special Tools List)
for
MODULAR PRINTING SYSTEM, MODULE B, PRESS SECTION
(NSN: 3610-01-283-4582)

Approved for public release; distribution is unlimited.

TM 5-3610-293-13&P, dated 22 August 1990, is changed as follows:

1. Appendix F, Unit and Direct Support Maintenance (Including Depot Maintenance) Repair Parts and Special Tools List (RPSTL), Sections II through IV, have been revised to incorporate 100% National Stock Number assignment. Because entire sections are revised, no change bars/hands are used in Appendix F.

Remove pages

F-11 through F-163/(F-164 blank)

Insert pages

F-11 through F-163/(F-164 blank)

2. Retain this sheet in front of manual for reference purposes.

By Order of the Secretary of the Army:

Official:

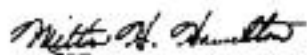

MILTON H. HAMILTON
Administrative Assistant to the
Secretary of the Army
01069

GORDON R. SULLIVAN
General, United States Army
Chief of Staff

DISTRIBUTION:

To be distributed in accordance with DA Form 12-25E, (qty rqr block nos. 5533)

WARNINGS

HIGH VOLTAGE

exists in the electrical system of this equipment.

DEATH ON CONTACT

may result if personnel fail to observe safety precautions.

Before performing continuity checks or replacing electrical components, make sure that electrical power is completely disconnected from the circuit involved.

In the event of fluorescent lamp breakage, care must be taken in the removal of broken glass fragments and white phosphorous dust. Inhalation of phosphorous dust could cause dangerous injury.

In extreme cold, do not touch metal parts with bare hands. Severe skin damage may result.

Safety goggles must be worn by personnel when drilling metal with an electric drill to prevent serious eye injury from flying metal fragments.

a/(b Blank)

TECHNICAL MANUAL
NO. 5-3610-293-13&P

HEADQUARTERS
DEPARTMENT OF THE ARMY
WASHINGTON, D.C., 22 August 1990

OPERATOR'S, UNIT AND DIRECT SUPPORT
MAINTENANCE MANUAL
INCLUDING REPAIR PARTS AND SPECIAL TOOLS LIST
MODULAR PRINTING SYSTEM, MODULE B, PRESS SECTION
(NSN: 3610-01-283-4582)

DISTRIBUTION STATEMENT A: Approved for public release; distribution is unlimited.

Current as of date
28 July 1990

REPORTING ERRORS AND RECOMMENDING IMPROVEMENTS

You can help improve this manual. If you find any mistake or if you know of a way to improve the procedures, please let us know. Mail your letter, DA Form 2028 (Recommended Changes to Publications and Blank Forms), or DA Form 2028-2 located in the back of this manual directly to: Commander, U.S. Army Aviation and Troop Command, ATTN: AMSAT-I-MP, 4300 Goodfellow Boulevard, St. Louis, MO 63120-1798. A reply will be furnished directly to you.

TABLE OF CONTENTS

Chapter/Section	Title	Page
CHAPTER 1	INTRODUCTION	1-1
Section I.	General Information	1-1
Section II.	Equipment Description and Data	1-5
Section III.	Technical Principles of Operation	1-13

TABLE OF CONTENTS-Continued

Chapter/Section	Title	Page
CHAPTER 2 OPERATING INSTRUCTIONS	2-1
Section I.	Description and Use of Operator's Controls and Indicators.....	2-1
Section II.	Operator Preventive Maintenance Checks..... and Services (PMCS)	2-17
Section III.	Operation Under Usual Conditions.....	2-27
Section IV.	Operation Under Unusual Conditions.....	2-49
CHAPTER 3 OPERATOR MAINTENANCE	3-1
Section I.	Lubrication Instructions.....	3-1
Section II.	Troubleshooting Procedures.....	3-5
Section III.	Operator Maintenance Procedures	3-11
CHAPTER 4 UNIT MAINTENANCE	4-1
Section I.	Unit Lubrication Instructions.....	4-1
Section II.	Repair Parts, Special Tools, TMDE and..... Support Equipment	4-3
Section III.	Service Upon Receipt of Equipment.....	4-5
Section IV.	Unit Preventive Maintenance Checks and Services.....	4-7
Section V.	Unit Troubleshooting	4-9
Section VI.	Unit Maintenance Procedures.....	4-21
CHAPTER 5 DIRECT SUPPORT MAINTENANCE PROCEDURES	5-1

LIST OF APPENDICES

		Page	Illust/ Figure
APPENDIX A.	REFERENCES	A-1	
APPENDIX B.	MAINTENANCE ALLOCATION CHART	B-1	
Section I.	Introduction.....	B-1	
Section II.	Maintenance Allocation Chart	B-5	
Section III.	Tool and Test Equipment Requirements	B-7	
Section IV.	Remarks	B-7	
APPENDIX C.	COMPONENTS OF THE END ITEM and BASIC ISSUE ITEMS LIST	C-1	
Section I.	Introduction.....	C-1	
Section II.	Components of End Item	C-3	
Section III.	Basic Issue Items.....	C-9	
APPENDIX D.	ADDITIONAL AUTHORIZED LIST ITEMS	D-1	
Section I.	Introduction.....	D-1	
Section II.	Additional Authorized List	D-1	
APPENDIX E.	EXPENDABLE/DURABLE SUPPLIES and MATERIALS LIST	E-1	
Section I.	Introduction.....	E-1	
Section II.	Expendable/Durable Supplies and Materials List.....	E-3	
APPENDIX F.	REPAIR PARTS and SPECIAL TOOLS LIST (RPSTL)	F-1	
Section I.	Introduction.....	F-1	
Section II.	Repair Parts List.....	F-10	
Group 01	Isatrol Control Box		
	Power Filter Assembly	F-11	1
Group 02	Cargo Door Vent Assembly		
	Cargo Door Vent Installation.....	F-13	2
Group 03	Air Conditioner Assembly		
	24K Air Conditioner Installation	F-15	3
	36K Air Conditioner Installation	F-17	4
	Air Conditioner Mounting Bracket Assembly	F-19	5
Group 04	Ducting Assembly, Air Conditioner		
	Duct Installation.....	F-21	6
	Ductwork Cap Installation	F-23	7
	Light Storage Assembly.....	F-25	8

Group 05	Ceiling Light Assembly		
	Fixed Roof Light Assembly	F-27	9
Group 06	Housing Assembly, Air Conditioner		
	Air Conditioner Housing Installation	F-29	10
	Air Conditioner Housing Equipment Mounting Installation	F-33	11
Group 07	Ink Cart and Tool Caddy Assembly		
	Ink Cart and Transporter Assembly.....	F-35	12
	Ink Cart Assembly	F-39	13
	Transporter Assembly.....	F-41	14
	Transporter Wheel Assembly	F-43	15
Group 08	GTO Cabinet Assembly		
	GTO Cabinet Assembly.....	F-45	16
	GTO Cabinet Modifications	F-47	17
	Roller Back Assembly.....	F-49	18
	Transporter Assembly.....	F-51	19
	Transporter Wheel Assembly	F-53	20
Group 09	Storage Cabinet, Wall Mounted		
	Wall Cabinet Assembly	F-55	21
Group 10	Table Folding		
	Folding Table Assembly	F-57	22
Group 11	Sink Assembly		
	Sink and Transporter Assembly.....	F-59	23
	Control Panel Assembly	F-61	24
	Sink Assembly.....	F-63	25
	Float Valve Assembly.....	F-65	26
	Sink Attaching Hardware	F-67	27
	Sink Piping Assembly	F-69	28
	Transporter Assembly.....	F-71	29
	Transporter Wheel Assembly	F-73	30
Group 12	Cabinet Assembly, Paper Jogging		
	Paper Jogging Cabinet and Transporter Assembly	F-75	31
	Paper Jogging Cabinet Assembly	F-77	32
	Transporter Assembly.....	F-79	33
	Transporter Wheel Assembly	F-81	34
Group 13	Work Transfer Cart		
	Work Cart Assembly.....	F-83	35
Group 14	Complexing Kit (Not Applicable)		
Group 15	Shelter, Iso		
	Outside Shelter Modifications.....	F-85	36
Group 16	Phase Monitor Meter		
	Phase Meter.....	F-87	37
Group 17	Rifle Rack Assembly		
	Weapons Rack Installation	F-89	38

Group 18	Blackout Buzzer Assembly		
	Blackout Buzzer Installation.....	F-91	39
	Blackout Switch Assembly.....	F-93	40
Group 19	Miscellaneous Support Items		
	Emergency Light Installation.....	F-95	41
	First Aid Kit Assembly	F-97	42
	Slide Hammer and Grounding Rod Installation	F-99	43
	Thermostat Assembly.....	F-101	44
	Storage Clamp Assembly	F-103	45
	Bulletin Board.....	F-105	46
	Solar Bar Wrench Handle Installation	F-107	47
	Solar Bar Handle Modifications	F-109	48
	Electrical Installation	F-111	49
	Power Panel Modifications	F-113	50
	Floor Inserts Installation	F-115	51
	Towel Dispenser Assembly.....	F-117	52
	Coat Rack Assembly	F-119	53
	Telephone Bracket Assembly	F-121	54
	Fire Extinguisher Assembly	F-123	55
	Eye Wash Assembly	F-125	56
Group 20	Printing Press		
	Printing Press Assembly.....	F-127	57
Section III.	Special Tools List (Not Applicable)	F-128	
Section IV.	Cross Reference Indexes.....	F-129	
	National Stock Number Index.....	F-129	
	Part Number Index	F-130	
	Figure and Item Number Index.....	F-147	
APPENDIX G.	ILLUSTRATED LIST OF MANUFACTURED ITEMS	G-1	

LIST OF FIGURES

Figure No.	Title	Page
1-1	Modular Printing System (MPS)	1-2
1-2	Outside Front View of Press Section	1-6
1-3	Outside Rear View of Press Section	1-7
1-4	Press Section Equipment Layout.....	1-8
2-1	Power Distribution Panel Controls and Indicators	2-2
2-2	Emergency Light	2-3
2-3	Hygrometer and Temperature Indicator	2-4
2-4	Islatrol Control Box.....	2-4
2-5	Phase Monitor Meter	2-6
2-6	Air Conditioner (AC) Units, 24,000 BTUH and 36,000 BTUH	2-8
	Controls and Indicators	
2-7	Air Conditioner Ceiling Duct Assembly (Looking at ceiling).....	2-9
2-8	Fluorescent Light Assemblies.....	2-10
2-9	Cargo Door AC Vent Assemblies.....	2-11
2-10	Sink Assembly	2-14
2-11	Transporter Assembly	2-15
2-12	Site Layout.....	2-28
2-13	Operating Location of Press Section Equipment.....	2-30
2-14	Ceiling Light Assembly	2-31
2-15	Ceiling Light Assemblies, Stored Location, View Looking up at Ceiling.....	2-32
2-16	Power Cable Connections to Press Section Shelter.....	2-34
2-17	Power Distribution Box Controls and Indicators	2-35
2-18	Setting Up Sink Assembly	2-39
2-19	Press Section Equipment Storage Location.....	2-42
2-20	Power Distribution Panel Data Index Card.....	2-43
2-21	Sink Assembly Decal Locations.....	2-44
2-22	Ink Cart and Tool Caddy Assembly Decal Locations.....	2-45
2-23	Printing Press Decal Locations.....	2-46
2-24	Transporter Assembly Decal Locations.....	2-47
2-25	Shelter Decal Locations	2-48
3-1	Air Conditioner Air Vent Door Hinges	3-2
3-2	Cargo Doors AC Vent Assemblies	3-3
3-3	Ceiling Light Assembly	3-12
3-4	AC Filters.....	3-13
3-5	Cargo Door Vent Filters.....	3-14

LIST OF FIGURES

Figure No.	Title	Page
4-1	Islatrol Control Box Assembly.....	4-22
4-2	Cargo Door Vent Assemblies	4-24
4-3	Air Conditioner Assembly (Outside).....	4-28
4-4	Air Conditioner Assembly (Inside)	4-29
4-5	Lifting Air Conditioner With Fork Lift.....	4-31
4-6	Air Conditioner Mounting Bracket Assembly (24,000 BTUH and 36,000 BTUH)	4-35
4-7	Air Conditioner Ducting Assembly 4-Way Register	4-36
4-8	End Registers.....	4-37
4-9	Solar Bar Push Rod Access Plate	4-38
4-10	Air Conditioner Housing Assembly	4-39
4-11	Sidewall Vent Assembly.....	4-40
4-12	Heating Element Access Plate	4-41
4-13	Front Wall Vent Assembly.....	4-42
4-14	Ink Cart and Tool Caddy	4-43
4-15	GTO Cabinet Assembly.....	4-45
4-16	Wall Mounted Storage Cabinet.....	4-47
4-17	Folding Table	4-48
4-18	Sink Assembly	4-51
4-19	Replace Fresh Water Pump	4-52
4-20	Replace Drain Pump	4-54
4-21	Replace Switch	4-57
4-22	Replace Power Supply	4-59
4-23	Replace Fuse Holder.....	4-61
4-24	Replace Water Heater.....	4-64
4-25	Replace Water Level Monitor	4-65
4-26	Replace Fresh Water and Gray Water Tank Level Probe.....	4-68
4-27	Replace Fresh Water and Gray Water Drain Solenoid	4-69
4-28	Replace Drain Pump Impeller	4-71
4-29	Replace Water Float Valve Assembly	4-73
4-30	Replace GFI Receptacle	4-75
4-31	Replace Transporter Assembly.....	4-77
4-32	Paper Jogging Cabinet Assembly.....	4-79
4-33	Work Transfer Cart	4-81
4-34	Repair Phase Monitor Meter.....	4-83
4-35	Repair Rifle Rack Assembly.....	4-90
4-36	Blackout Buzzer Assembly.....	4-93
4-37	Emergency Light.....	4-94
FO-1	Sink Assembly Wiring Diagram.....	FO-1
FO-2	Phase Monitor Meter Wiring Diagram.....	FO-2

LIST OF TABLES

Table No.	Title	Page
2-1	Operator Preventive Maintenance Checks and Services (PMCS).....	2-19
3-1	Operator Troubleshooting.....	3-5
4-1	Press Section Checklist.....	4-5
4-2	Unit Troubleshooting	4-9

HOW TO USE THIS MANUAL

This manual is used by the Army for operation and maintenance of the Press Section, Module B. Use front cover index and black tabs at the edge to quickly find the chapters, appendices and index of the manual.

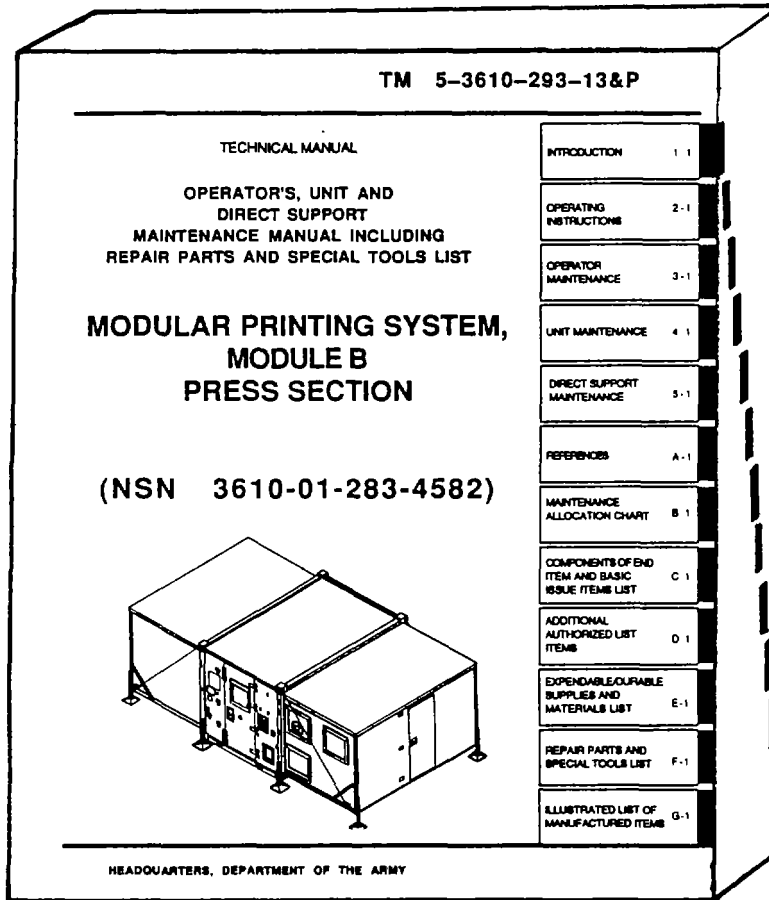

This manual is divided into chapters, sections, and paragraphs which are numbered in sequence. Pages and paragraphs are numbered by chapters. For example: Chapter 2, page 3 is marked 2-3; Chapter 3, paragraph 5 is marked 3-5.

CHAPTER 1. INTRODUCTION

SECTION I. GENERAL INFORMATION

1-1. SCOPE.

- a. Type of Manual. Operating Instructions, Unit and Direct Support Maintenance.
- b. Model Number and Equipment Name. Model Number-None assigned. Modular Printing System (MPS), Module B, Press Section of the Army Special Warfare Modular Printing System, hereafter referred to as the Press Section.
- c. Purpose of Equipment. The Press Section contains a two-color printing press limited to 8,000 sheets per hour. The purpose of the Press Section is to print leaflets for distribution areas. The Press Section greatly expands the production capability of Army Psychological Operations (PSYOPS) units through use of its high-speed commercial printing press. Refer to Figure 1-1 for a layout of the Modular Printing System.
- d. Supplementing Manuals. The following manuals contain operating and maintenance instructions for other components of the MPS.

- (1) TM 5-3610-294-13&P Finishing Section (Module C)
- (2) TM 5-4120-395-14&P Air Conditioner Unit, 24,000 BTUH
- (3) TM 5-4120-396-14&P Air Conditioner Unit, 36,000 BTUH
- (4) TM 5-3610-295-13&P-1 Editorial and Photomechanical Shelter, Module A, Volume 1
- (5) TM 5-3610-295-13&P-2 Press Shelter, Module A, Volume 2

1-2. **MAINTENANCE FORMS AND RECORDS**. Department of the Army forms and procedures used for equipment maintenance will be those prescribed by DA Pamphlet 738-750, The Army Maintenance Management System (TAMMS).

1-3. **REPORTING EQUIPMENT IMPROVEMENT RECOMMENDATIONS (EIR's)**. If your Press Section needs improvement, let us know. Send us an EIR. You, the user, are the only one who can tell us what you don't like about your equipment. Let us know why you don't like the design or performance. Put it on an SF 368 (Quality Deficiency Report). Mail it to: Commander, U.S. Army Aviation and Troop Command, ATTN: AMSAT I-MDO, 4300 Goodfellow Boulevard, St. Louis, MO 63120-1798. We'll send you a reply.

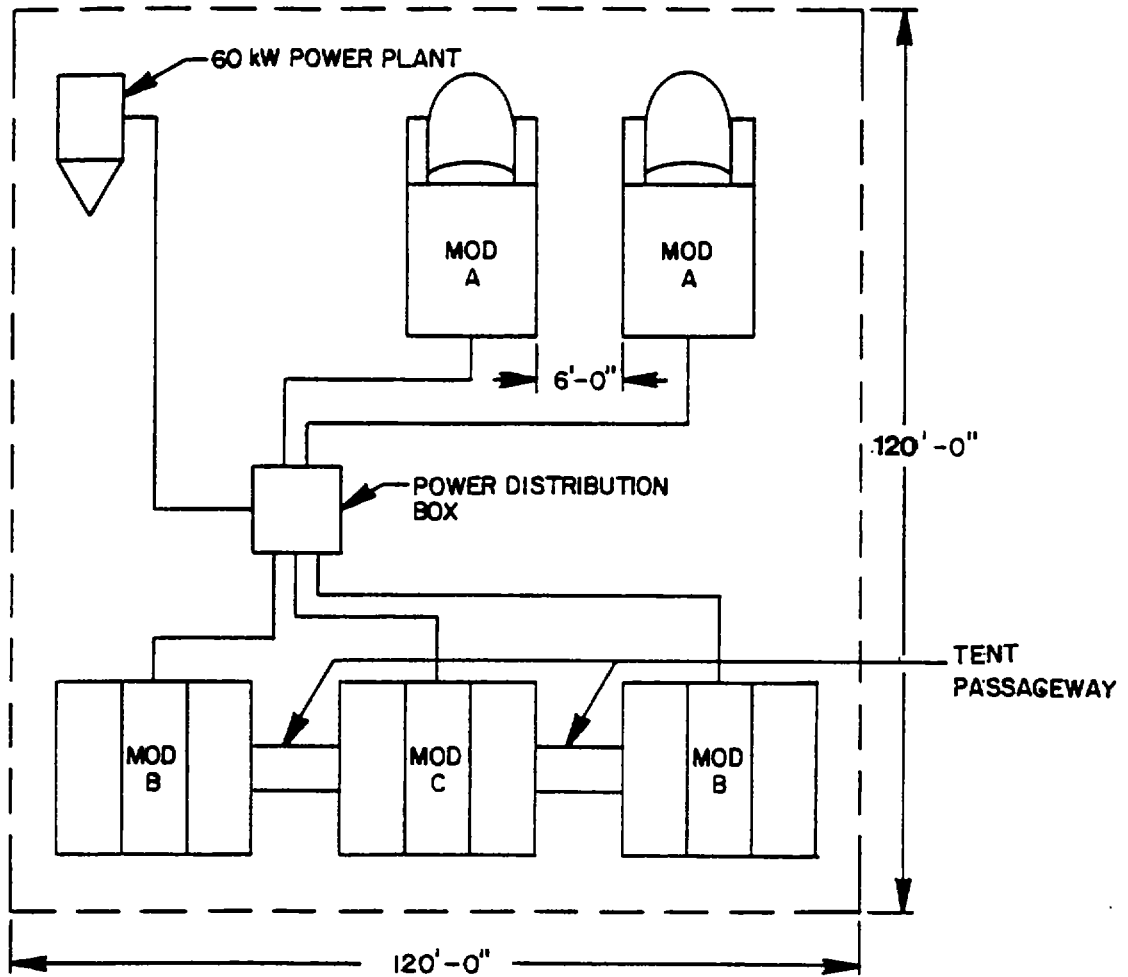

SITE LAYOUT

Figure 1-1. Modular Printing System (MPS)

1-4. **WARRANTY INFORMATION.** Refer to individual component manuals for warranty information.

1-5. **DESTRUCTION OF ARMY MATERIAL TO PREVENT ENEMY USE.** For destruction procedures for material, refer to TM750-244-3.

1-6. **PREPARATION FOR STORAGE OR SHIPMENT.** Refer to Chapter 2, Section III, paragraph 2-15, for instructions on preparation of equipment for storage or shipment.

1-7. **DEPOT MAINTENANCE.** Depot maintenance for the Modular Print System is performed by a specially trained depot team. Requests for depot maintenance should be forwarded to the U.S. Army Troop Support Command, Directorate for Maintenance, ATTN: AMSTR-MPD, 4300 Goodfellow Boulevard, St. Louis, Missouri 63210-1798, AUTOVON 693-9413 or commercial (314) 263-9413.

1-8. **LIST OF ABBREVIATIONS.**

I

IPH	Impressions Per Hour
ISO	International Standardization Organization

M

MPS	Modular Printing System
-----	-------------------------

P

PSYOPS	Psychological Operations
--------	--------------------------

S

SPH	Sheets Per Hour
-----	-----------------

SECTION II. EQUIPMENT DESCRIPTION AND DATA

1-9. EQUIPMENT CHARACTERISTICS, CAPABILITIES AND FEATURES.

a. Equipment Characteristics. The Press Section is housed in a tactical, two-sided expandable shelter. All equipment is designed to be stored in the center section of the shelter for storage or transport. The Press Section is a vehicular transportable reproduction/printing facility used in conjunction with Modules A and C of the Modular Printing System.

b. Equipment Capabilities. The Press Section provides Army Psychological Operations (PSYOPS) battalions high-speed, two-color printing of propaganda material for delivery to dissemination points. It is heated and air conditioned, and can operate 24 hours a day in all weather conditions.

c. Equipment Features. The Press Section contains a high-speed commercial printing press, two air conditioners, tables and specially designed paper carrying and storage carts. It also contains overhead fluorescent lighting and specially designed air conditioning duct work for temperature control.

1-10. **LOCATION AND DESCRIPTION OF MAJOR COMPONENTS**. Left and right orientation is determined by facing the ISO shelter personnel door from the outside. Paragraph numbers below correspond to callouts in Figure 1-2 through figure 1-4. All equipment is located in its operational position.

a. Outside Front View of Shelter. Refer to Figure 1-2 for location of major components.

(1) Personnel Door-Provides means for entering the shelter.

(2) Blackout Button-When depressed, sounds buzzer. Used only during blackout conditions.

1-10. LOCATION AND DESCRIPTION OF MAJOR COMPONENTS. -Continued

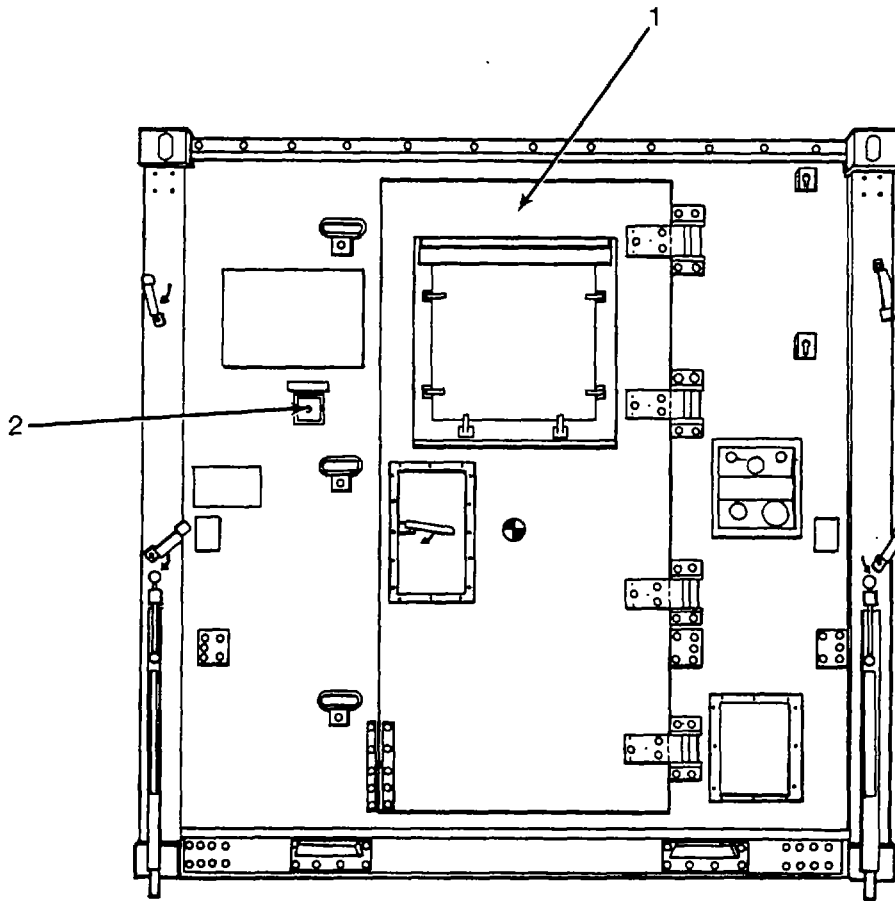

Figure 1-2. Outside Front View of Press Section

b. Outside Rear View of Shelter. Refer to Figure 1-3 for location of major components.

(1) Cargo Doors-Provides access to air conditioning units.

(2) Air Conditioner Vents-Provides fresh air circulation for air conditioners. Must be opened for operation and for transport by aircraft.

1-10. LOCATION AND DESCRIPTION OF MAJOR COMPONENTS. -Continued

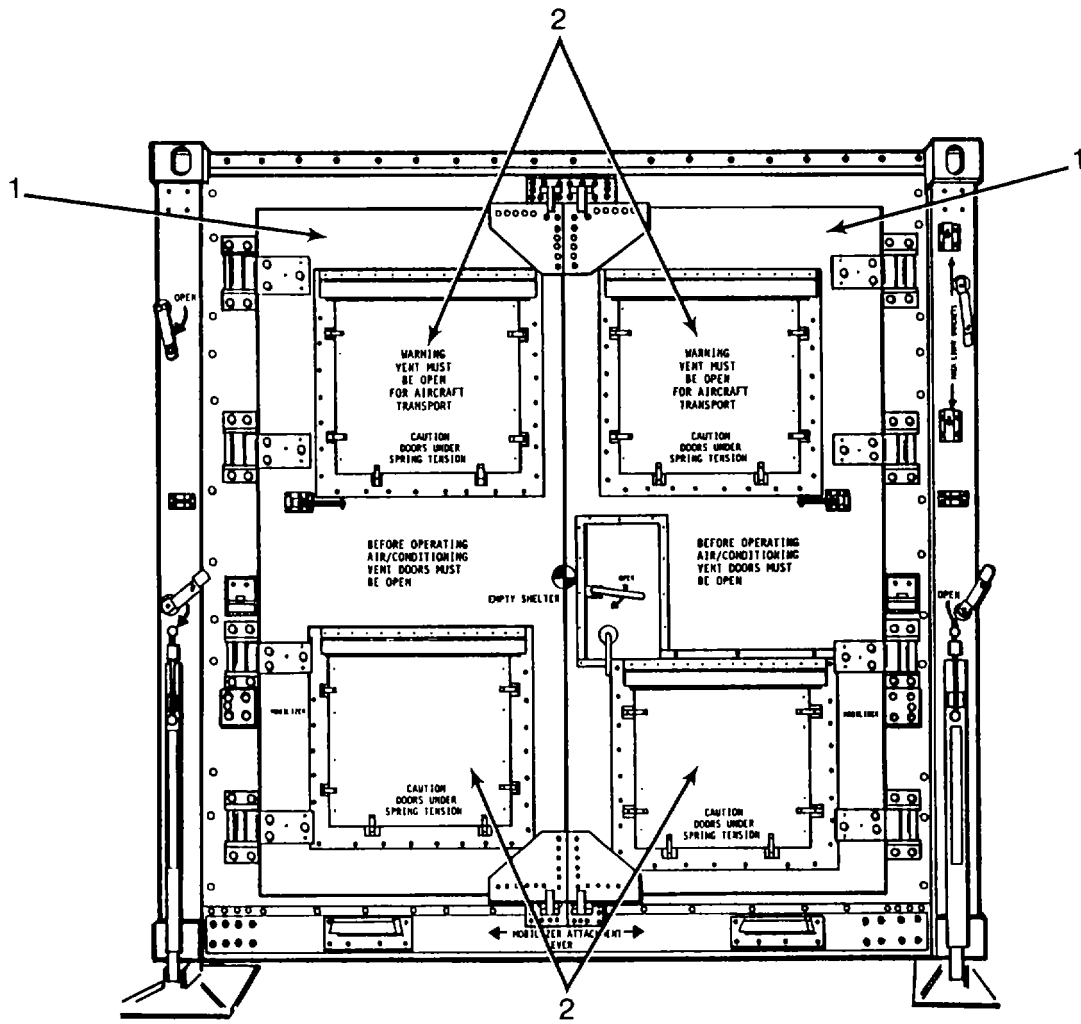

Figure 1-3. Outside Rear View of Press Section

1-10. LOCATION AND DESCRIPTION OF MAJOR COMPONENTS. -Continued

c. Interior View of Press Section. Refer to Figure 1-4 for location of major components.

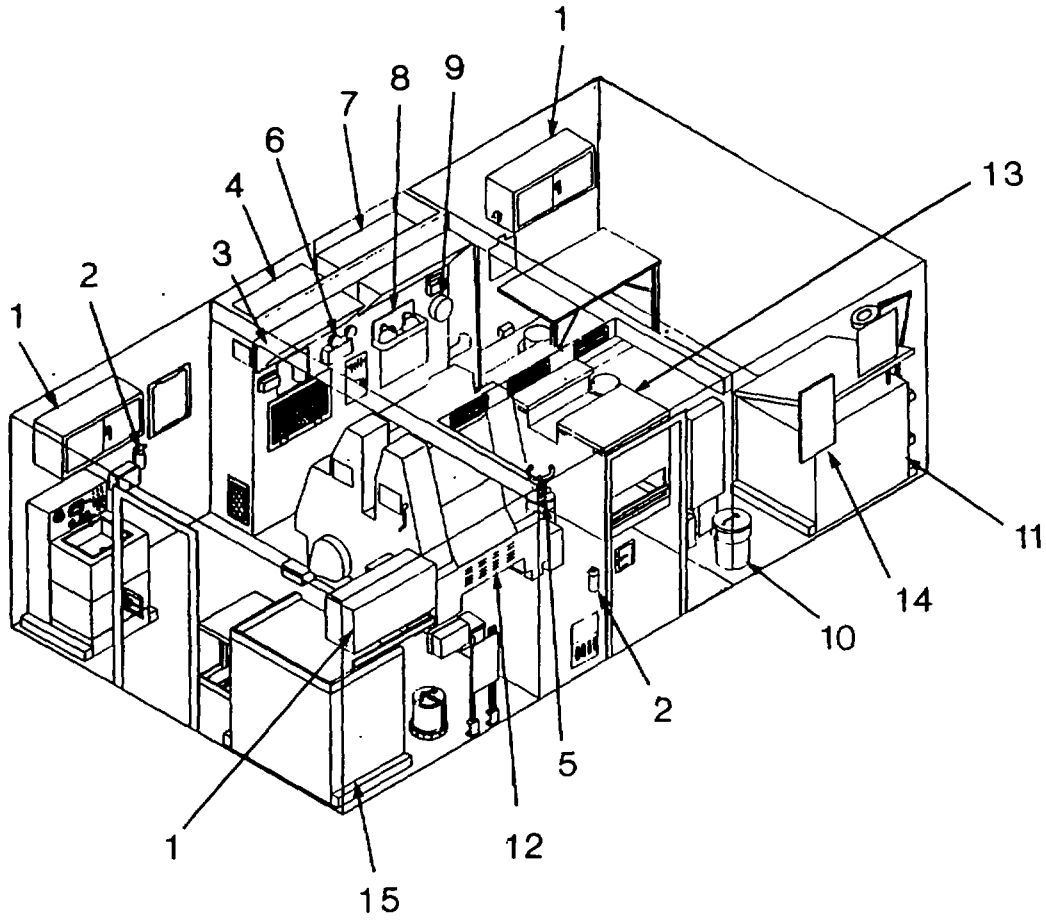

Figure 1-4. Press Section Equipment Layout (Sheet 1 of 2)

1-10. LOCATION AND DESCRIPTION OF MAJOR COMPONENTS. -Continued

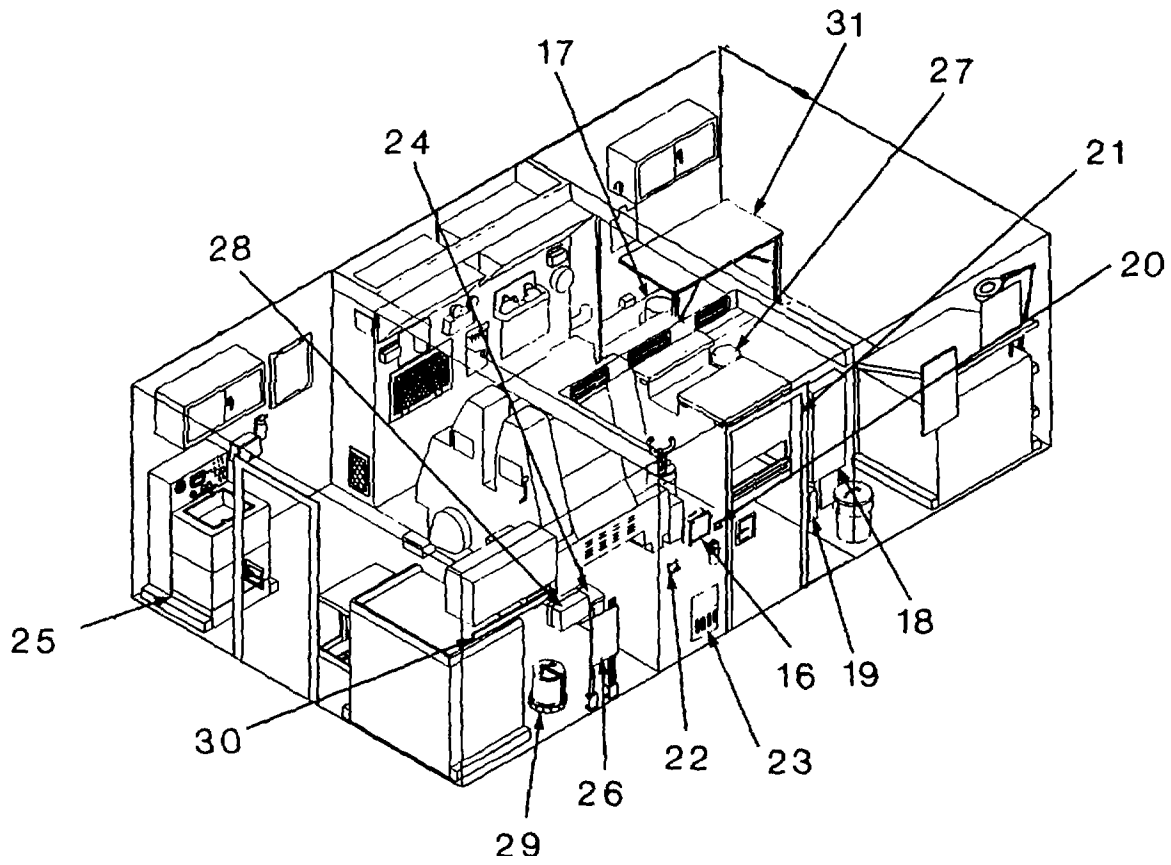

Figure 1-4. Press Section Equipment Layout (Sheet 2 of 2)

1-10. LOCATION AND DESCRIPTION OF MAJOR COMPONENTS. -Continued

- (1) Wall Storage Cabinet-Standard 2-door storage cabinet with one shelf. The shelter contains three storage cabinets.
- (2) Fire Extinguisher-Two Class 2-B dry chemical type fire extinguishers suitable for all types of fires except for liquid oxygen generating equipment.
- (3) Solar Bar-Secures ISO shelter roof in place. Handle has been modified for MPS application.
- (4) Air Conditioner Unit, Model 36WH-Heat pump and air conditioning unit with manual changeover thermostat.
- (5) Eyewash Station-Isotonic eyewash station.
- (6) Emergency Light-Battery powered light which activates automatically if the shelter loses power.
- (7) Air Conditioner Unit, Model 24WH-Heat pump and air conditioner with manual changeover thermostat.
- (8) Liquid Container Rack-Storage rack for liquids.
- (9) Hygrometer and Temperature Indicator-Monitors barometric pressure and temperature in the Press Section shelter.
- (10) Trash Can-44-gallon trash can.
- (11) GTO Cabinet-Storage cabinet with ball bearing drawer, add-on top with two shelves (one with lock) . The GTO cabinet also includes a tilt top and a magnifier lamp.
- (12) Printing Press-a high speed, two-color off-set perfecting printing press rated at 8,000 sheets per minute.
- (13) Ink and Tool Caddy Cart-Used for carrying printing press supplies and for printing plate storage.
- (14) Bulletin Board-Cork faced board for posting messages.
- (15) Paper Jogging Cabinet-Table top for stacking paper and cabinet for storage.
- (16) Telephone-Standard telephone and storage bracket.

1-10. LOCATION AND DESCRIPTION OF MAJOR COMPONENTS. -Continued

- (17) Step Stool-Metal step stool.
- (18) Power Distribution Panel-Contains circuit breakers and distribution terminals for shelter electrical system.
- (19) Phase Monitor Meter-Monitors electrical voltage, frequency and three phase input power to the shelter.
- (20) Blackout Buzzer-A push-button switch to alert personnel to extinguish lighting in the shelter.
- (21) Personnel Door-Provides entrance into the shelter.
- (22) Level-all-Used when leveling the shelter.
- (23) Rifle Rack-Provides storage for weapons.
- (24) Islatrol Control Box-A line filter for input power to the printing press to suppress power fluctuations.
- (25) Sink Assembly-Provides hot and cold water for cleaning hands and equipment.
- (26) Slide Hammer-Hammer tool used for placement and removal of ground rod.
- (27) Stool-A personnel stool.
- (28) Paper Towel Dispenser-Storage container for paper hand towels.
- (29) Flammable Waste Container-A 10-gallon metal container for storage of flammable waste.
- (30) Coat Rack-Rack with hooks used to hang clothing.
- (31) Folding Table-A table hinged on shelter wall.

1-11. **EQUIPMENT DATA.**

- a. Air Conditioner Unit 24,000 BTUH. Refer to TM 5-4120-395-14&P for technical data on the unit.
- b. Air Conditioner Unit 36,000 BTUH. Refer to TM 5-4120-396-14&P for technical data on the unit.
- c. Offset Printing Press. Refer to TM 5-3610-304-10/20/20P for technical data on equipment.
- d. 3/1 Shelter. Refer to TM 10-5411-200-14/24P for technical data on the shelter.

1-12. **SAFETY, CARE AND HANDLING.** You should follow the safety practices listed on the "WARNING" pages at the front of this manual, as well as using good common sense. In addition, always read the applicable **WARNINGS** and **CAUTIONS** listed immediately before a dangerous operating or maintenance procedure.

SECTION III. TECHNICAL PRINCIPLES OF OPERATION

1-13. **PRINCIPLES OF OPERATION.** The Press Section provides the MPS with additional printing capacity of up to 8,000 sheets per hour per Press Section. Because Module B contains only a printing press, it must rely upon the editorial capabilities of Module A to provide printing and photograph plates. The product of the Press Section is printed sheets which are then moved to the Finishing Section, Module C for cutting, collating and other finishing processes as required.

Module B is comprised of two identical Press Sections, each capable of providing an additional 8,000 sheets per hour printing capacity to the MPS. The MPS can function with one or both of the Press Sections.

a. Printing and Production. The Modular Printing System provides printing and production capabilities for Psychological Operations (PSYOPS) battalions. These capabilities include sustained direct printing operations, photographic processing, layout of negatives, photolithographic plate processing, and packaging functions. The MPS is a transportable, self-contained printing plant (including its own power generator) capable of world-wide deployment under all weather conditions. See Figure 1-1.

b. MPS System Equipment. The MPS consists of three modules: (1) Printing Plant, Module A; (2) Press Section, Module B; (3) Finishing Section, Module C. Module A is comprised of two 5-280 shelters, each mounted on a 2 1/2 ton truck. The Photomechanical/Editorial Shelter contains typesetting, art work preparation, darkroom and plate making capabilities. The Press Shelter contains limited capacity printing and paper cutting capabilities.

c. MPS Press Section (Module B). Module B is comprised of two Press Sections, each of which is a two-sided expandable 8' x 8' x 20' tactical rigid wall 150 shelter. Each shelter is equipped with a two-color offset perfecting printing press, environment controls, sink, lithographic layout cabinet, work tables and storage space for printing supplies.

d. MPS Finishing Section (Module C). Module C is comprised of one Finishing Section which is also a two-sided 150 shelter equipped with a programmable hydraulic paper cutter, environmental controls, storage cabinets and work tables. Two ISO-to-ISO connectors allow passage between the three 150 units.

e. Power Requirements and Distribution. Power for the entire system is provided by a 60 KW trailer-mounted power plant. Module A, when operated in a stand alone configuration without Modules B and C, has its own power source of two 15 KW generators that are part of the standard Lightweight Printing Plant configuration. When Module A is configured with Modules B and C, the two 15 KW generators are replaced by the single 60 KW power plant providing power for the entire system. A Power Distribution Box Assembly provides central power distribution and control to the five units of the MPS.

1-13. **PRINCIPLES OF OPERATION.** -Continued

f. Movement of MPS. Movement of Modules B and C is accomplished by two five-ton cargo trucks with the shelters mounted on ISO mobilizers.

1-14. **ADDITIONAL REFERENCE MATERIAL.** Detailed information relating to commercial equipment used in the shelter is available in the respective commercial technical manuals listed in Appendix A and will not be repeated in this manual. Where applicable, the reader will be directed to refer to the appropriate commercial technical manual.

CHAPTER 2. OPERATING INSTRUCTIONS

SECTION I. DESCRIPTION AND USE OF OPERATOR'S CONTROLS AND INDICATORS

2-1. **POWER DISTRIBUTION PANEL** Refer to Figure 2-1 for location of controls and indicators. Numbers in parenthesis after control or indicator listed below appear as callouts in figure.

- a. Circuit Breaker (1) - Provides overload protection for interior utility outlets mounted on left rear wall and air conditioner room light.
- b. Circuit Breaker (2) - Provides overload protection for interior utility outlets mounted on hinged right front and rear walls and emergency light outlet.
- c. Circuit Breaker (3) - Provides overload protection for interior utility outlets mounted on left front wall.
- d. Circuit Breaker (4) - Provides overload protection for 36,000 BTUH air conditioner supply receptacle mounted on power entry panel.
- e. Main Circuit Breaker (5) - In ON position, delivers electrical power to individual circuit breakers. In OFF position, turns off all electrical power in shelter, except for the phase monitor assembly.
- f. Circuit Breaker (6) - Provides overload protection for ground fault interrupter utility outlet mounted on power entry panel.
- g. Circuit Breaker (7) - Provides overload protection for ceiling lights and blackout warning system.
- h. Circuit Breaker (8) - Provides overload protection for printing press.
- i. Circuit Breaker (9) - Provides overload protection for 24,000 BTUH air conditioner.
- j. Blackout Override Switch (10) - In the ON position, overrides door activated blackout switch mounted on the front wall adjacent to the personnel door. During blackout conditions switch must be in the OFF position.
- k. Incandescent Light Switch (11) - In the ON position, turns on left front wall light. In OFF position, turns off left front wall light.

2-1. POWER DISTRIBUTION PANEL. -Continued

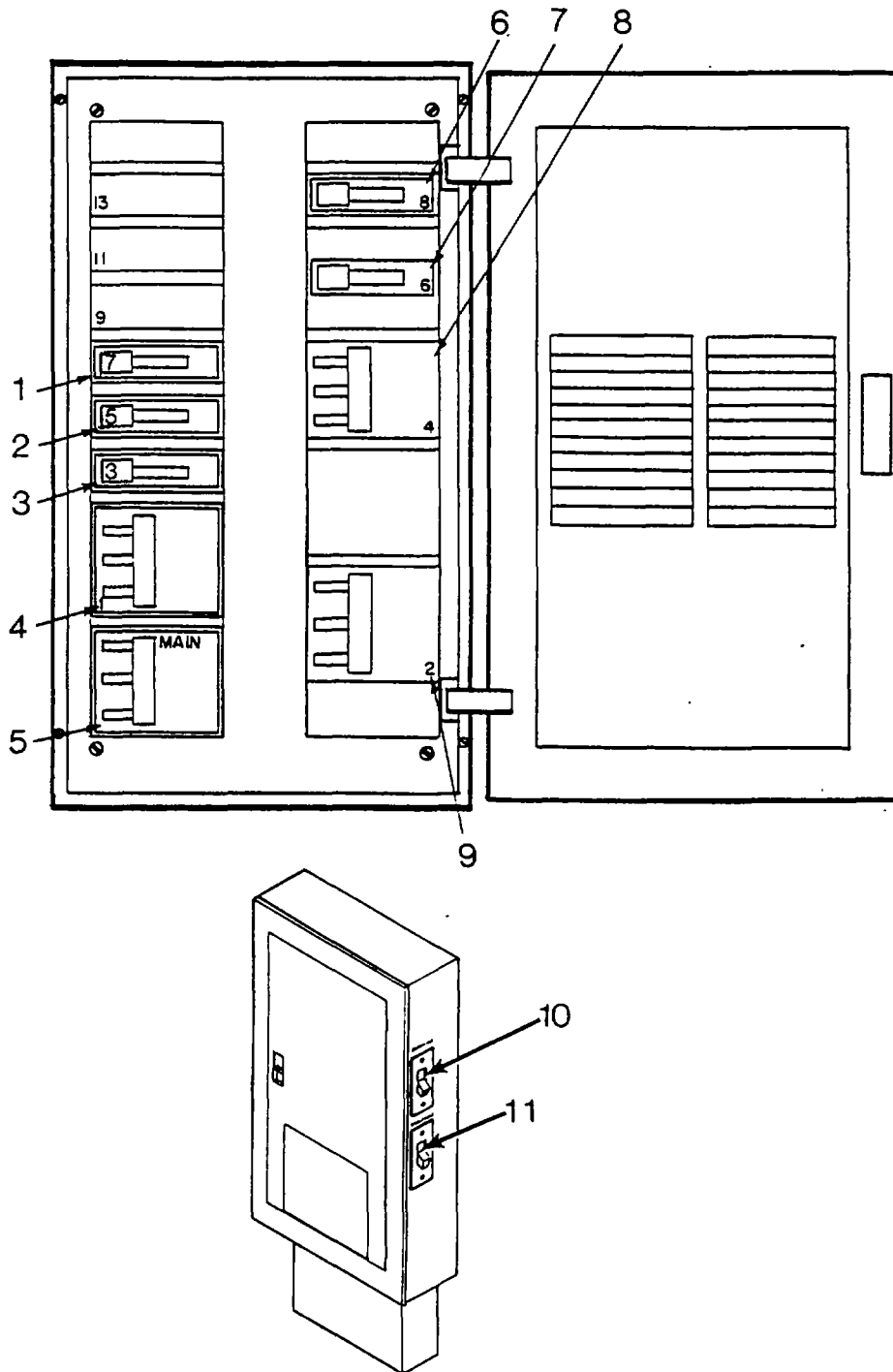

Figure 2-1. Power Distribution Panel Controls and Indicators

2-2. **EMERGENCY LIGHT.** The emergency light is self-activating when input power to the shelter is lost. The test switch allows the operator to check the condition of the batteries. Refer to Figure 2-2 for location of controls and indicators.

- a. Ready Light (1) - Indicates power is ON.
- b. ON/OFF Power Switch (2) - In the ON position, connects battery to the circuit. In the OFF position, disconnects battery from the circuit.
- c. Test Switch (3)-Switch for testing condition of the battery. When pushed, the bulbs in the emergency light will light. Test switch works only when ON/OFF power switch is in the ON position.
- d. Charge Light (4)-Indicates when battery is charging. Charge light works only when ON/OFF power switch is in the ON position.

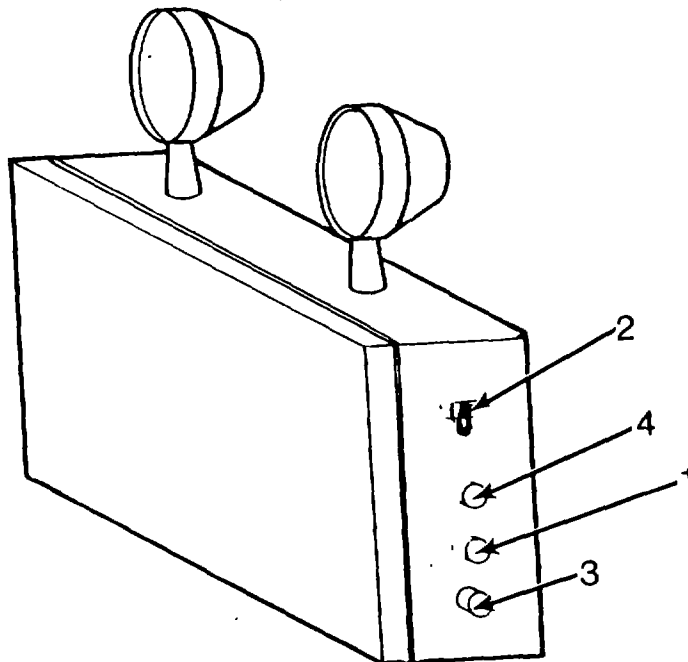

Figure 2-2. Emergency Light

2-3. **HYGROMETER AND TEMPERATURE INDICATOR.** The hygrometer indicates the relative humidity and temperature inside the shelter. There are no operator controls or adjustments.

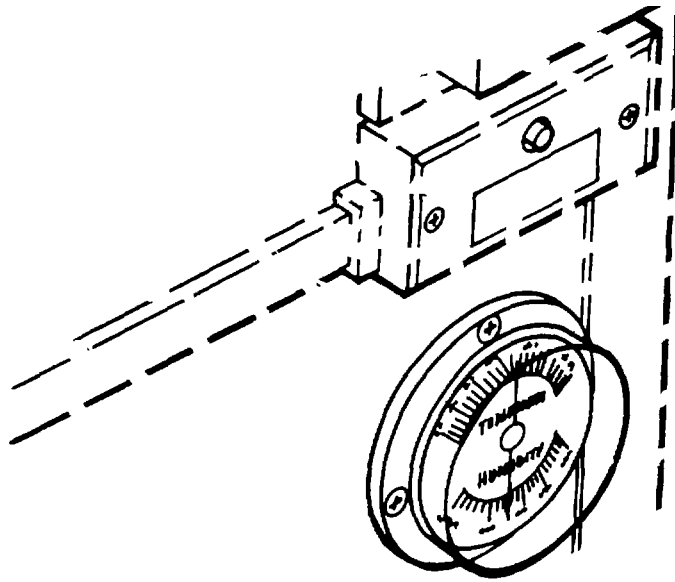

Figure 2-3. Hygrometer and Temperature Indicator

2-4. **ISIATROL CONTROL BOX.** The islatrol control box, located on the lower drive side of the printing press, contains an electrical filter to isolate the printing press from the rest of the electrical circuit.

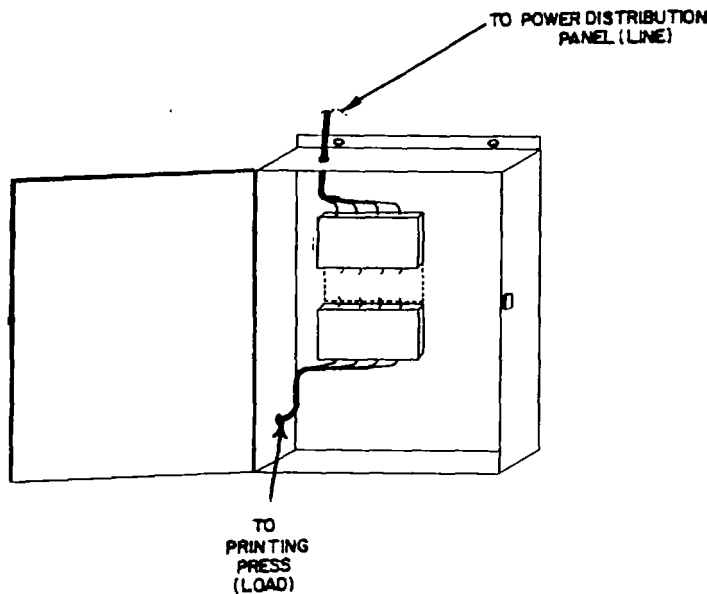

Figure 2-4. Islatrol Control Box

2-5. **PRINTING PRESS.** Refer to TM 5-3610-304-10 for description and use of operator's controls and indicators.

2-6. **PHASE MONITOR METER.** The phase monitor meter allows the operator to monitor electrical frequency, voltage and three-phase input power to the shelter. Refer to Figure 2-5 for location of operator's controls and indicators.

- a. Phase/Test Switch (1) - Allows the operator to check for correct/incorrect input power phase.
- b. Frequency Meter (2) - Allows the operator to monitor the frequency of each electrical phase as determined by the Phase Select Switch. The meter does not function when the Phase Select Switch is in the OFF position.
- c. Phase Selector Switch (3) - A four position (OFF, A, B, C) switch for selecting the electrical phase to be monitored. This switch should remain in the OFF position when the phase meter is not in use.
- d. Correct Phase Indicator (4) - Indicator lamp which lights to indicate presence of a correct electrical phase (A, B, C) being monitored.
- e. Voltage Meter (5) - Allows the operator to monitor the voltage of each electrical phase as determined by the Phase Selector Switch. The meter does not function when the Phase Selector Switch is in the OFF position.
- f. Incorrect Phase Indicator (6) - Indicator lamp which lights to indicate the presence of an incorrect electrical phase (A, B, C) that is being monitored.
- g. Fuse (7) - Protects the Phase Monitor Meter from an electrical overload.

2-6. PHASE MONITOR METER. - Continued

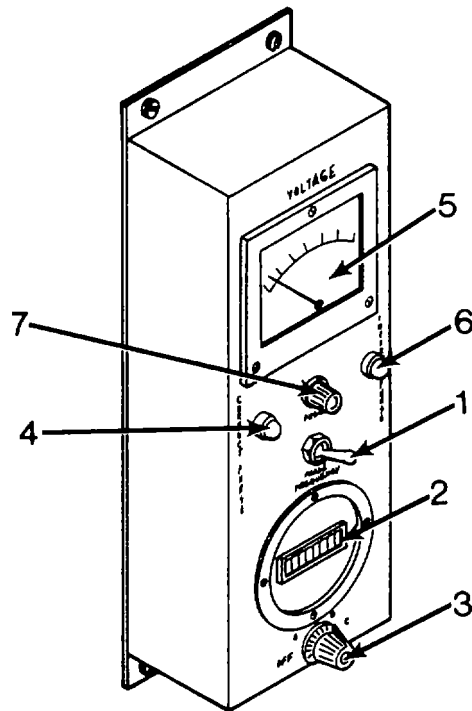

Figure 2-5. Phase Monitor Meter

2-7. **AIR CONDITIONER (AC) UNITS (24,000 BTUH AND 36,000 BTUH).** Each air conditioner has a separate thermostat for controlling temperature; however, the controls and indicators are the same for both. Refer to Figure 2-6 for location of operator's controls and indicators.

- a. Temperature Set Point Lever (1) - Allows the operator to select the cooling or heating temperature point. The AC units will cycle on and off automatically as the shelter temperature fluctuates about the selected temperature.

2-7. AIR CONDITIONER (AC) UNITS (24,000 BTUH AND 36,000 BTUH). - Continued

- b. Heat/Cool Switch (2) - In the HEAT position, AC operates to heat the shelter. In the COOL position, AC operates to cool the shelter.
- c. Fan Switch (3) - A two position switch for controlling the automatic or manual operation of the fan. When placed in the ON position, the fan operates continuously. When placed in the AUTO position, the fan operates automatically during heating and cooling cycles as controlled by the setting of the thermostat.
- d. Thermometer (4) - Indicates ambient air temperature inside the shelter in degrees Fahrenheit.
- e. Exhaust Vent Warning Light (5) - Indicator lamp which lights to warn that the AC exhaust vents on the cargo doors are closed when attempting to energize the AC's. The AC's will not operate until the vent doors are opened.
- f. NORM/EMERG HEAT Switch (6) - In the NORM position, heat pump is used for heating. In the EMERG HEAT position, electrical heating coils are used to supplement the heat pump.
- g. Emergency Heat Indicator (7) - Indicator lights when emergency heat is on.
- h. Air Input Vent With Filter (8 and 9) - Brings air to the outside coils. Filter keeps dirt and dust from entering the AC.
- i. Air Input Vent with Filter (10 and 11) - Brings air (heating or cooling) to the inside coils. Filter keeps dust and dirt from entering the shelter.

2-7. AIR CONDITIONER (AC) UNITS (24,000 BTUH AND 36,000 BTUH). - Continued

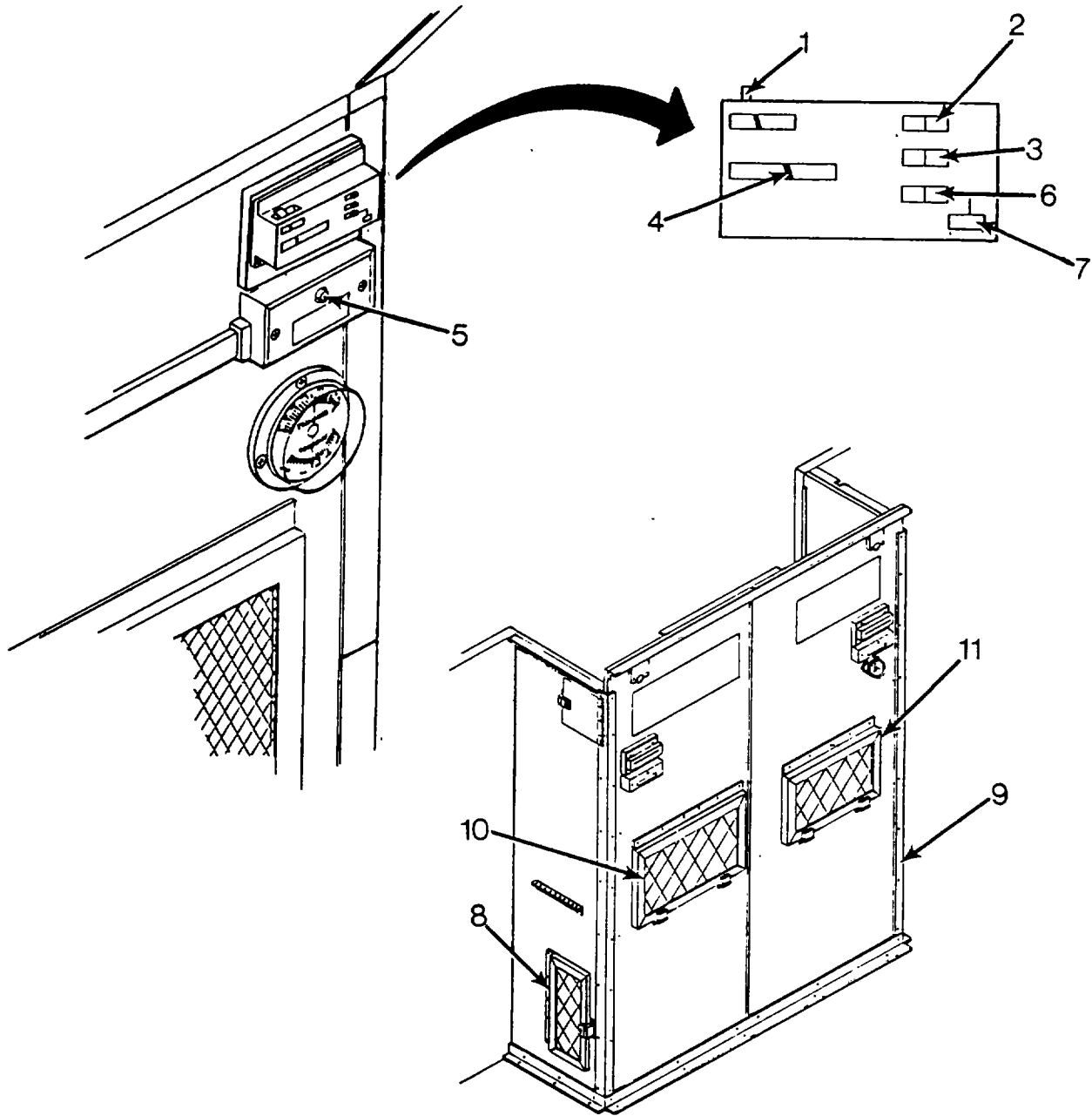
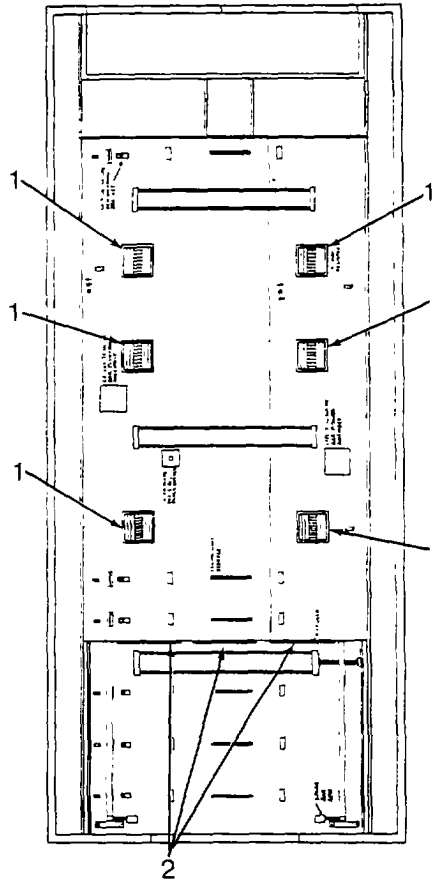

Figure 2-6. Air Conditioner (AC) Units, 24,000 BTUH and 36,000 BTUH Controls and Indicators

2-8. **AIR CONDITIONER CEILING DUCT ASSEMBLY.** Refer to Figure 2-7 for location of operator's controls and indicators. The ducting and vent assemblies provide even distribution of conditioned air throughout the shelter.

- a. Ceiling Registers Hand Operated (6 each) (1) - Allows the operator to control the flow of air to the interior of the shelter.
- b. End Registers, (3 each) (2) - Provides flow of air to the front of the shelter.



**Figure 2-7. Air Conditioner Ceiling Duct Assembly
(Looking at ceiling)**

2-9. **FLUORESCENT LIGHT ASSEMBLIES.** Provide overhead lighting in the shelter.

- a. Housing Assembly (1) - Provides housing and electrical power for the light bulbs.
- b. Fluorescent Light Bulbs (2) - Provide lighting in the shelter.

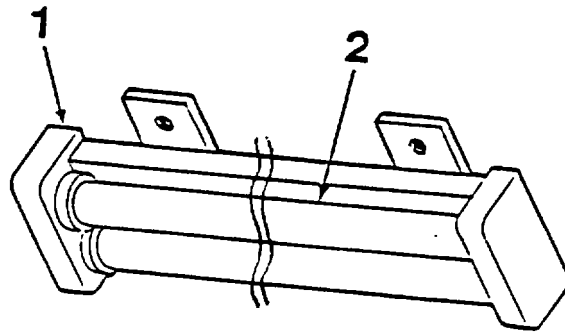

Figure 2-8. Fluorescent Light Assemblies

2-10. **CARGO DOOR AC VENT ASSEMBLIES.** Top vents (one in each door) (1, Figure 2-9) allow outside air to enter the AC units. Bottom vents (one in each door) (2) allow air to escape from the AC units. All vents must be opened for the AC units to operate.

2-10. CARGO DOOR AC VENT ASSEMBLIES. - Continued

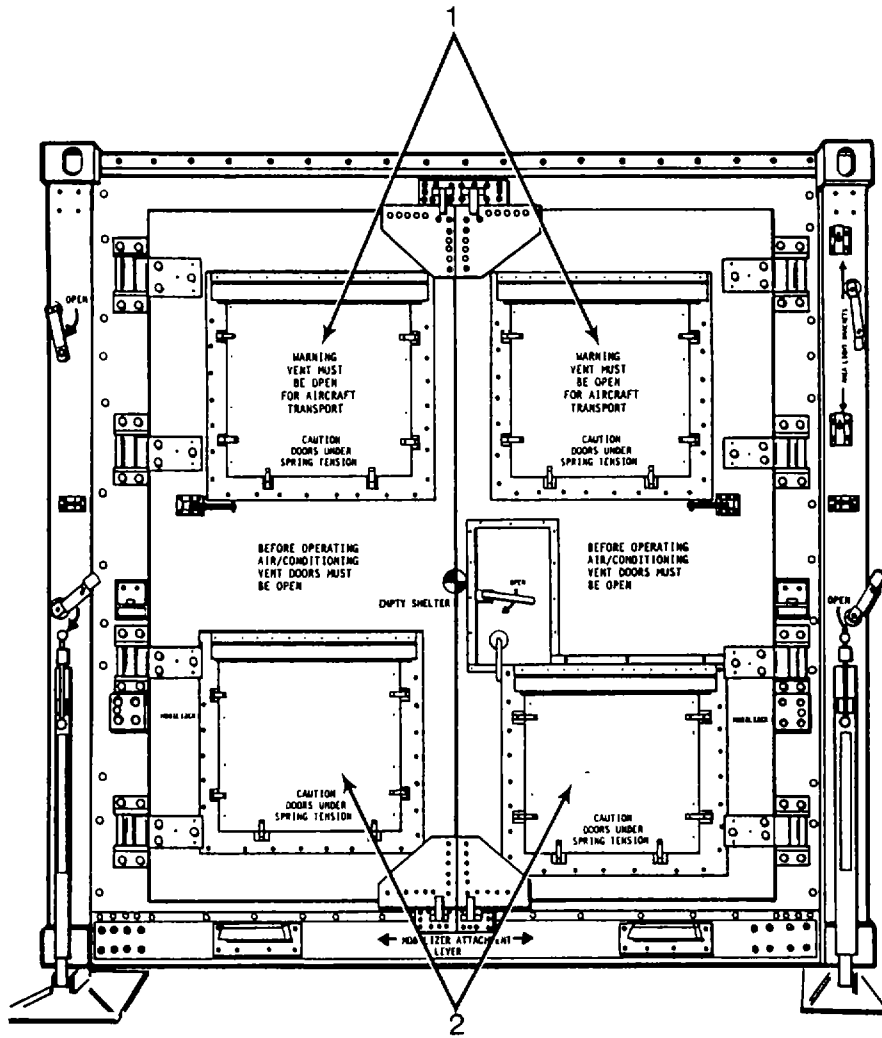

Figure 2-9. Cargo Door AC Vent Assemblies

2-11. **SINK ASSEMBLY.** Refer to figure 2-10 for location of controls and indicators.

- a. Thermometer (1) - Indicates temperature of water in water tank.
- b. Water Level Indicator (2) - Indicates level of water in fresh water tank when water level switch (14) is in FRESH WATER LEVEL position. Indicates level of water in gray water tank when water level switch (14) is in GRAY WATER LEVEL position. Indicates empty when water level switch (14) is in OFF position. Indicates only when press to test switch is pushed.
- c. Press to Test Switch (3) - Must be pressed to activate water level indicator (2).
- d. Adjust to Full Knob (4) - Provides for calibration of fresh water and gray water level probes. When fresh water tank is full and water level switch (14) is in FRESH WATER LEVEL position, rotate adjust to full knob until water level indicator (2) reads FULL. Press to test switch must be pushed for indicator to read full.
- e. Drain Fresh Water Indicator (5) - Indicates when fresh water tank has been selected for draining.
- f. Drain Gray Water Indicator (6) - Indicates when gray water tank has been selected for draining.
- g. Drain Pump Indicator (7) - Indicates when drain pump is operating.
- h. Fresh Water Tank Indicator (8) - Indicates when water level switch (14) is in FRESH WATER LEVEL position.
- i. Gray Water Tank Indicator (9) - Indicates when water level switch (14) is in GRAY WATER LEVEL position.
- j. Fresh Water Pump Indicator (10) - Indicates when fresh water pump is activated.
- k. Water Heater Switch (11) - Red lighted switch which turns water heater on or off. Switch is lighted when water heater is on.
- l. Drain Pump Switch (12) - In the OFF position, turns drain pump off. In the ON position, turns drain pump on.
- m. Gray Water/Fresh Water Drain Switch (13) - In the OFF position, overrides drain pump switch (12) and does not allow activation of drain pump. In the GRAY WATER DRAIN position, switches drain pump to gray water tank. In the FRESH WATER DRAIN position, switches drain pump to fresh water tank.

2-11. **SINK ASSEMBLY.** - Continued

n. Water Level Switch (14) - In the OFF position, deactivates water level probes and indicator (2). In the GRAY WATER LEVEL position, activates gray water level probe. In the FRESH WATER LEVEL position, activates fresh water level probe.

o. Fresh Water Pump Switch (15) - In the ON position, activates fresh water pump. In the OFF position, deactivates fresh water pump.

p. Hot Water Tank Drain Valve (16) - When turned fully clockwise to closed position, allows hot water tank to be filled. When turned fully counterclockwise to open, allows hot water tank to be drained. In normal operation, the hot water tank drain valve should be closed.

CAUTION

Never set temperature greater than 160° F. Failure to do so may result in damage to the sink assembly.

q. Hot Water Temperature Control Knob (17) - Sets temperature of water in hot water tank. Operator should not adjust hot water temperature control knob. This is a unit maintenance function. Under no circumstance should setting be greater than 160° F.

2-11. SINK ASSEMBLY. - Continued

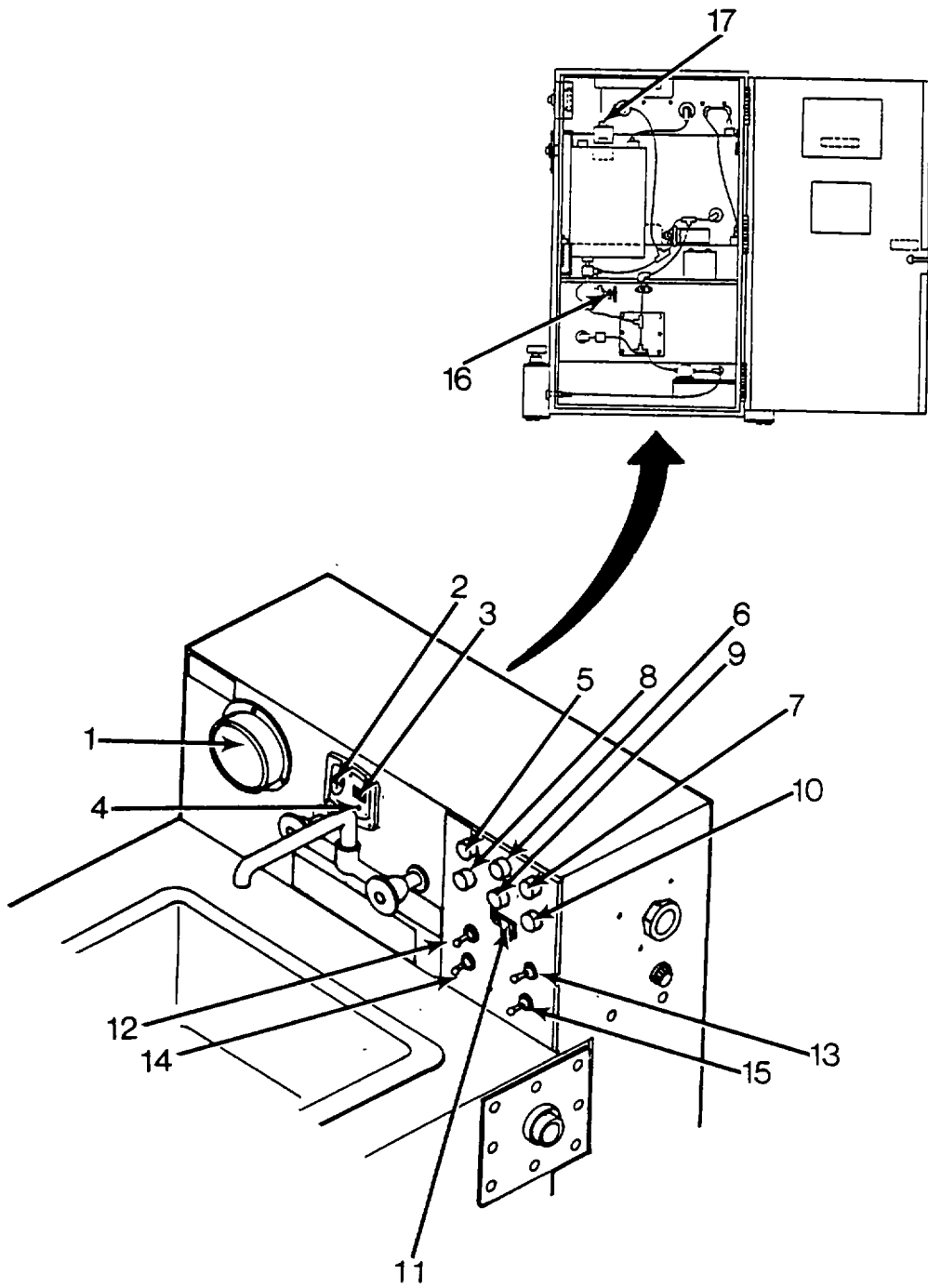

Figure 2-10. Sink Assembly

2-12. **TRANSPORTER ASSEMBLY.** Refer to figure 2-11 for location of controls and indicators.

- a. Hand Knob (1) - When turned clockwise, lowers wheels to allow movement of equipment assembly attached to transporter assemblies. When turned counterclockwise, raises wheels to allow equipment assembly to set on shelter floor.

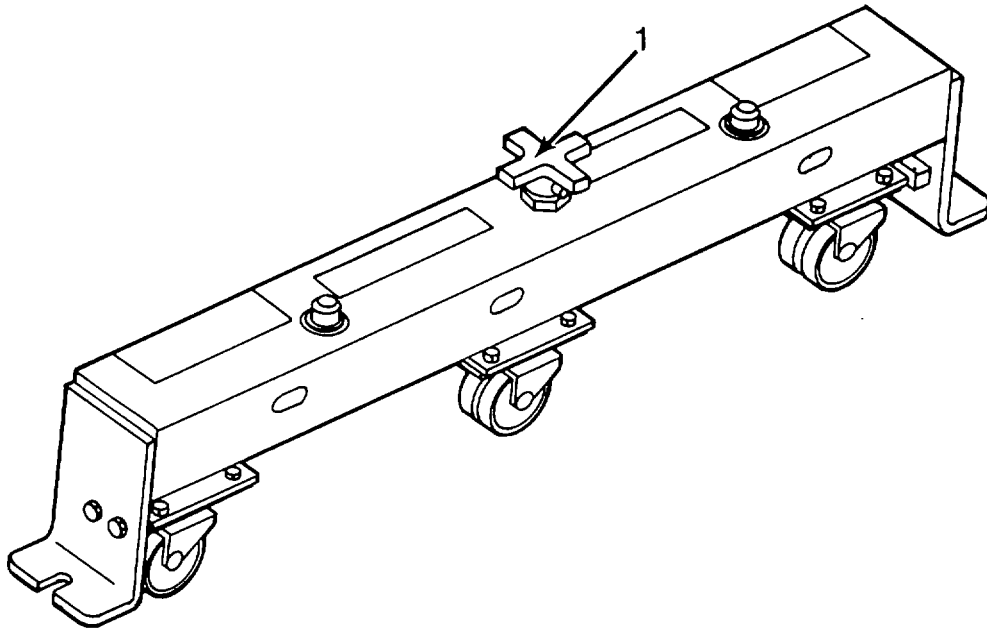

Figure 2-11. Transporter Assembly

2-15/(2-16 Blank)

SECTION II. OPERATOR PREVENTIVE MAINTENANCE CHECKS AND SERVICES (PMCS)

2-13. INTRODUCTION.

a. General. Your Preventive Maintenance Checks and Services table lists the inspection and care of your equipment required to keep it in good operating condition.

(1) Before you operate. Always keep in mind the CAUTIONS and WARNINGS. Perform your before (B) PMCS.

(2) While you operate. Always keep in mind the CAUTIONS and WARNINGS. Perform your during (D) PMCS.

(3) After you operate. Be sure to perform your after (A) PMCS.

(4) If your equipment fails to operate. If your equipment does not perform as required, refer to Chapter 3 under Troubleshooting for possible problems.

b. PMCS Columnar Entries.

(1) Item number column. This is the order in which you perform checks and services on the devices.

(2) Interval columns. The interval column of your PMCS table tells you when to do a certain check or service.

(3) Item to be inspected column. Identification of item to be inspected.

(4) Procedures column. The procedures column of your PMCS table tells you how to do the required checks and services. Carefully follow these instructions. If you do not have the tools, or if the procedure tells you to, have the next higher level of maintenance do the work.

(5) Equipment is not ready/available if: column. Entries in this column will be keyed specifically to checks listed in the "procedures" column for the purpose of identifying, for the check, the criteria that will cause the equipment to be classified as not ready/available because of inability to perform its primary Combat Mission. An entry in this column will:

- * Identify conditions that make the equipment not ready/available for readiness reporting.
- * Deny use of the equipment until corrective maintenance has been performed.

2-13. **INTRODUCTION.** - Continuedc. Special Instructions.

(1) Perform weekly in this and associated equipment manuals as well as before operations PMCS if:

- * You are the assigned operator and have not operated the item since the last weekly.
- * You are operating the item for the first time.

(2) Leakage definitions for operator/crew PMCS shall be classified as follows:

Class I - Seepage of fluid (as indicated by wetness or discoloration) not great enough to form drops.

Class II - Leakage of fluid great enough to form drops but not enough to cause drops to drip from item being checked/inspected.

Class III - Leakage of fluid great enough to form drops that fall from the item being checked/inspected.

CAUTION

Equipment operation is allowable with minor leakages (Class I or II). Of course, you must consider the fluid capacity in the item/system being checked/inspected. When in doubt, notify your supervisor.

When operating with Class I or II leaks, continue to check fluid levels as required in your PMCS.

Class III leaks should be reported to your supervisor.

2-13. **INTRODUCTION.** - Continued**Table 2-1. Operator Preventive Maintenance Checks and Services (PMCS)****WARNING**

SHUT OFF generator engine before performing any maintenance to prevent possible electrical shock. If the engine must be run, make sure the area is well ventilated. The exhaust fumes contain poisonous carbon monoxide gas which can cause **DEATH**.

NOTE

If the equipment must be kept in continuous operation, check and service only those items that can be checked and serviced without disturbing operation. Make the complete checks and services when the equipment can be shut down.

2-13. INTRODUCTION. - Continued

Table 2-1. Operator Preventive Maintenance Checks and Services (PMCS) (Cont.)
B - Before D - During A - After

Item No.	Interval			Item To Be Inspected Procedure	Equipment is not Ready/ Available if:
	B	D	A		
1	•		•	Power Distribution Panel - Visual Inspection <p style="text-align: center;">WARNING</p> <p>High Voltage exists in the electrical system of this equipment. DEATH on contact may result if personnel fail to observe safety precautions.</p> <ol style="list-style-type: none"> 1. Inspect for damage to door and panel. 2. Inspect circuit breakers for operation, condition security. 	Damaged, missing or loose Door or panel damaged. Circuit breakers not and operating.
2	•		•	<p>Emergency Light - Check operation of light.</p> <ol style="list-style-type: none"> 1. Test battery by operating test switch with ON/OFF switch in ON position. 2. Check Ready light. 3. Check light bulbs for operation with ON/OFF switch in ON position. 	Lights do not operate when test switch is activated. Ready light does not operate when circuit breaker switch is turned ON. Lights do not operate when test switch is activated.

2-13. INTRODUCTION. - Continued

Table 2-1. Operator Preventive Maintenance Checks and Services (PMCS) (Cont.)

Item No.	Interval			Item To Be Inspected Procedure	Equipment is not Ready/ Available if:
	B - Before	D - During	A - After		
3	•	•	•	<p>Hygrometer and Temperature Indicator - Visual Inspection</p> <ol style="list-style-type: none"> 1. Inspect cover for damages. 2. Inspect temperature gauge for damages. 	<p>Cover damaged.</p> <p>Temperature gauge cracked or broken.</p>
4	•		•	<p>Islatrol Control Box - Visual Inspection.</p> <p>Check cover for damages and loose or missing hardware.</p>	<p>Cover is damaged or Hardware is loose or missing.</p>
5	•		•	<p>Printing Press - Visual Inspection (Note: Refer to TM 5-3610-304-10 for PMCS procedures.)</p>	
6	•		•	<p>Phase Monitor Meter</p> <ol style="list-style-type: none"> 1. Inspect cover for damages. 2. Check switches for damages. 3. Check meters for proper operation. 4. Check indicator lamps for proper operation 	<p>Cover is dented or damaged.</p> <p>Switches not operating.</p> <p>Meters do not register.</p> <p>Lamps do not light.</p>

2-13. INTRODUCTION. - Continued

Table 2-1. Operator Preventive Maintenance Checks and Services (PMCS) (Cont.)

Item No.	Interval			Item To Be Inspected Procedure	Equipment is not Ready/ Available if:
	B - Before	D - During	A - After		
7	•	•	•	<p>Thermostat</p> <ol style="list-style-type: none"> 1. Inspect temperature set point lever for correct operation. 2. Check thermometer for proper operation. 	<p>Temperature set point lever does not adjust temperature.</p> <p>Thermometer indicator does not register correct temperature.</p>
8	•	•	•	<p>Air Conditioner (AC) Units (24,000 BTUH and 36,000 BTUH)</p> <ol style="list-style-type: none"> 1. Check switches for proper operation. 2. Check levers for correct operation. 3. Check thermostat for correct reading. 4. Check vent warning light for operation by closing one cargo vent. 5. Inspect filters for excessive dust or dirt. 6. Spray filters with filter coater. 	<p>Switches do not activate correct settings.</p> <p>Lever do not allow for proper setting.</p> <p>Thermostat does not register correctly.</p> <p>Vent warning light does not activate when vents are closed.</p> <p>Cooling or heating is impaired and filters are dirty.</p> <p>Filters not coated.</p>

2-13. INTRODUCTION. - Continued

Table 2-1. Operator Preventive Maintenance Checks and Services (PMCS) (Cont.)

B - Before D - During A - After

Item No.	Interval			Item To Be Inspected Procedure	Equipment is not Ready/ Available if:
	B	D	A		
9	•		•	<p>Air Conditioner Ducting Assembly</p> <ol style="list-style-type: none"> 1. Inspect louvers for ease of operation. 2. Check duct assembly for damages or loose hardware. 	<p>Louvers are damaged and will not open or close.</p> <p>Duct assembly is badly damaged or hardware is missing.</p>
10	•	•	•	<p>Ceiling Light Assembly</p> <ol style="list-style-type: none"> 1. Inspect housing for damages or loose or missing hardware. 2. Check bulbs for operation. 	<p>Damages prevent proper lighting.</p> <p>Bulbs do not light when switch is turned on.</p>
11	•		•	<p>Cargo Door Vent Assembly</p> <ol style="list-style-type: none"> 1. Inspect vent assembly for loose or missing hardware and damaged or broken springs. 2. Inspect vents for dents or damages. 3. Inspect filters for cleanliness. 	<p>Vent door will not remain open when opened.</p> <p>Vents are dented or bent and will not stay opened or closed.</p> <p>Filters are clogged with dirt.</p>

2-13. INTRODUCTION. - Continued

Table 2-1. Operator Preventive Maintenance Checks and Services (PMCS) (Cont.)

Item No.	Interval			Item To Be Inspected Procedure	Equipment is not Ready/ Available if:
	B - Before	D - During	A - After		
12	•		•	<p>Air Conditioner Housing Assembly</p> <ol style="list-style-type: none"> 1. Inspect vent assembly for loose or missing hardware. 2. Inspect vents for dents or damages. 3. Inspect filters for cleanliness. 	<p>Vent door will not open properly.</p> <p>Vents are dented or bent.</p> <p>Filters are clogged with dirt.</p>
13	•	•	•	<p>Ink Cart and Tool Caddy</p> <ol style="list-style-type: none"> 1. Inspect hinges for loose or missing hardware. 2. Inspect door latch for broken handle or loose missing hardware. 3. Inspect transporter assembly for ease of operation. 	<p>Doors fail to open properly.</p> <p>Door latch broken or mounting hardware missing.</p> <p>Transporter assembly broken or damaged.</p>
14	•	•	•	<p>GTO Cabinet Assembly</p> <ol style="list-style-type: none"> 1. Inspect light assembly for proper operation. 2. Inspect transporter assembly for ease of operation. 	<p>Light does not operate when switch is turned ON.</p> <p>Transporter assembly broken or damaged.</p>

2-13. INTRODUCTION - Continued

Table 2-1. Operator Preventive Maintenance Checks and Services (PMCS) (Cont.)

Item No.	Interval			Item To Be Inspected Procedure	Equipment is not Ready/ Available if:
	B - Before	D - During	A - After		
15		•		3. Inspect mounting brackets for loose or missing hardware. Wall Mounted Storage Cabinets	Hardware loose or missing on cabinet.
16	•		•	1. Inspect door hinges and latch for ease of operation. 2. Inspect general condition of cabinet for dents or loose or missing hardware. Folding Table	Door fails to open or close properly. Cabinet contains severe dents or hardware is loose or missing.
17	•	•	•	1. Inspect table legs and braces for bent or broken parts. 2. Inspect general condition of table top. Sink Assembly	Table will not lock in place when raised for operation. Table top contains gouges or broken parts.
				1. Inspect controls/indicators for proper operation. 2. Inspect sink plumbing for leaks.	Sink fails to produce desired water (hot or cold) when properly adjusted. Water leaks from the sink.

2-13. INTRODUCTION - Continued

Table 2-1. Operator Preventive Maintenance Checks and Services (PMCS) (Cont.)

B - Before D - During A - After

Item No.	Interval			Item To Be Inspected Procedure	Equipment is not Ready/ Available if:
	B	D	A		
18	•			3. Inspect transporter assembly for proper operation. Paper Jogging Cabinet Assembly	Transporter assembly broken or damaged.
19	•			1. Inspect transporter assembly for ease of operation. 2. Inspect mounting brackets for loose or missing hardware. Work Transfer Cart 1. Inspect transporter assembly for ease of operation. 2. Inspect cart for loose or missing hardware.	Transporter assembly broken or damaged. Hardware loose or missing on cabinet. Transporter assembly broken or damaged. Hardware loose or missing on cart.

SECTION III. OPERATION UNDER USUAL CONDITIONS**2-14. ASSEMBLY AND PREPARATION FOR USE**

a. Site Selection. Refer to Figure 2-12 for a typical setup of the MPS system. The site selected should be as follows:

- (1) Terrain slope can be no more than 8 inches over the 120 foot depth or width of the site.
- (2) Module B and C unexpanded shelters must be positioned no less than 232 inches apart and no more than 241 inches apart.
- (3) Module B and C expanded shelters must be no less than 66 inches apart and no more than 75 inches apart.
- (4) Site should allow for a reasonable maneuvering area around the equipment.
- (5) Terrain should be firm, reasonably level, well drained and relatively free of large surface rocks.

NOTE

Scissors jacks are provided to supplement the standard ISO support jacks due to the weight of the printing press. After the center section of the shelter has been leveled, remove the scissors jacks from ceiling storage just inside the personnel door and use jack handles stowed on personnel door to firmly place two scissors jacks evenly spaced under each center section outside longitudinal beam.

2-14. ASSEMBLY AND PREPARATION FOR USE. - Continued

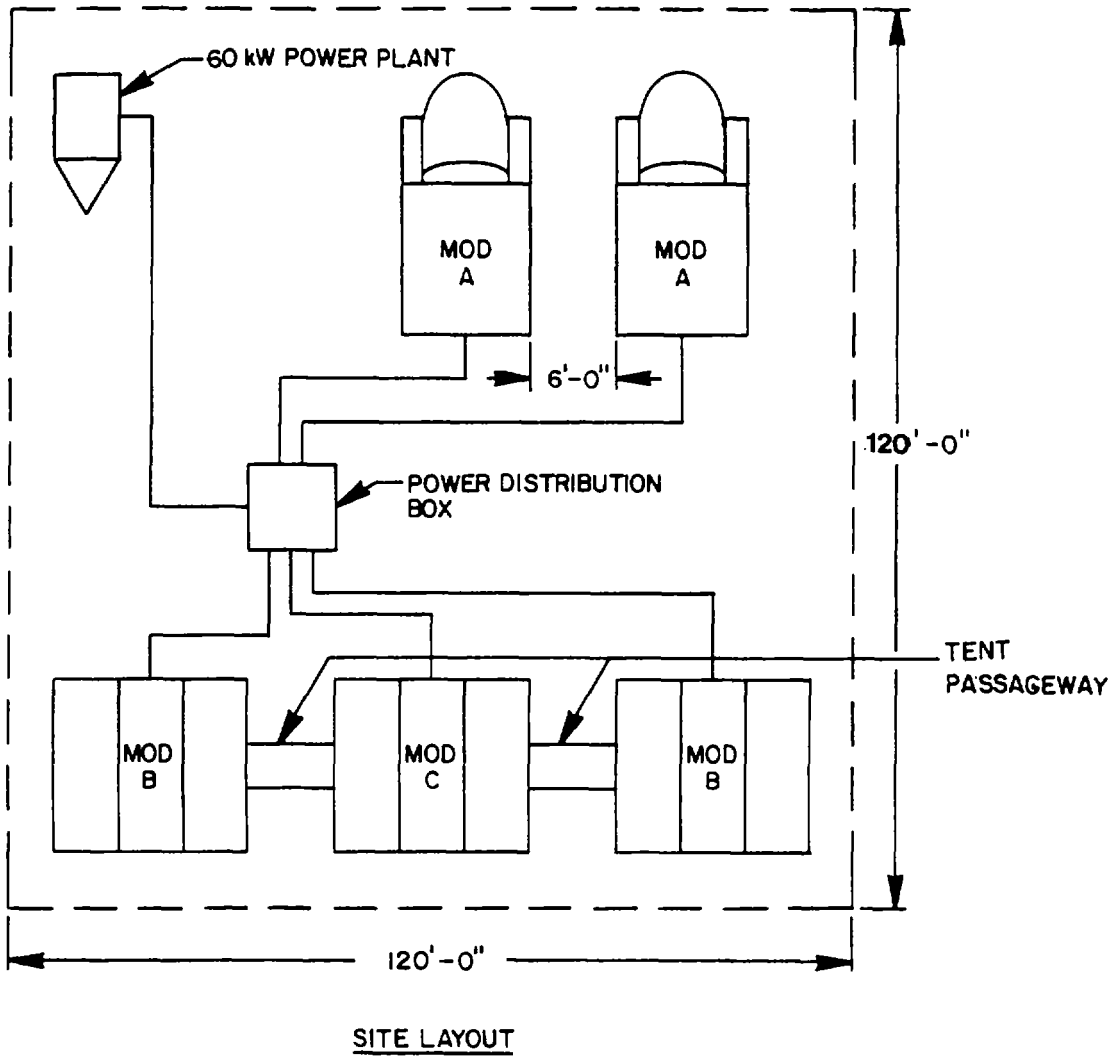

Figure 2-12. Site Layout

2-14. **ASSEMBLY AND PREPARATION FOR USE.** - Continued**NOTE**

The solar bar levers on the rear end of the shelter have been removed due to lack of clearance at the air conditioner housing. A ratchet wrench is supplied for use in rotating the solar bar and is stowed inside the cargo door on the 36,000 BTUH air conditioner side.

b. Setup of Shelter. Refer to TM 10-5411-200-14 for detailed instructions for setting up the shelter.

c. Press Section Interior Equipment. Refer to Figure 2-13 for a typical location of Press Section equipment when setup for operation. Remove the equipment from the center section of the shelter in the order listed below using T-handle retainer wrench located to the right of the personnel door to remove retainer bolts. Store retainer bolts in proper location on transporter assemblies.

NOTE

Equipment stored in the center section of the shelter, with the exception of the Printing Press, may be placed anywhere within the shelter.

2-14. **ASSEMBLY AND PREPARATION FOR USE.** - Continued

- (1) Ink cart and Tool Caddy
- (2) GTO Cabinet Assembly
- (3) Folding Chair
- (4) Paper Jogging Cabinet Assembly
- (5) Sink Assembly
- (6) Stools and waste cans
- (7) Floor mat (place between printing press and air conditioner units.)

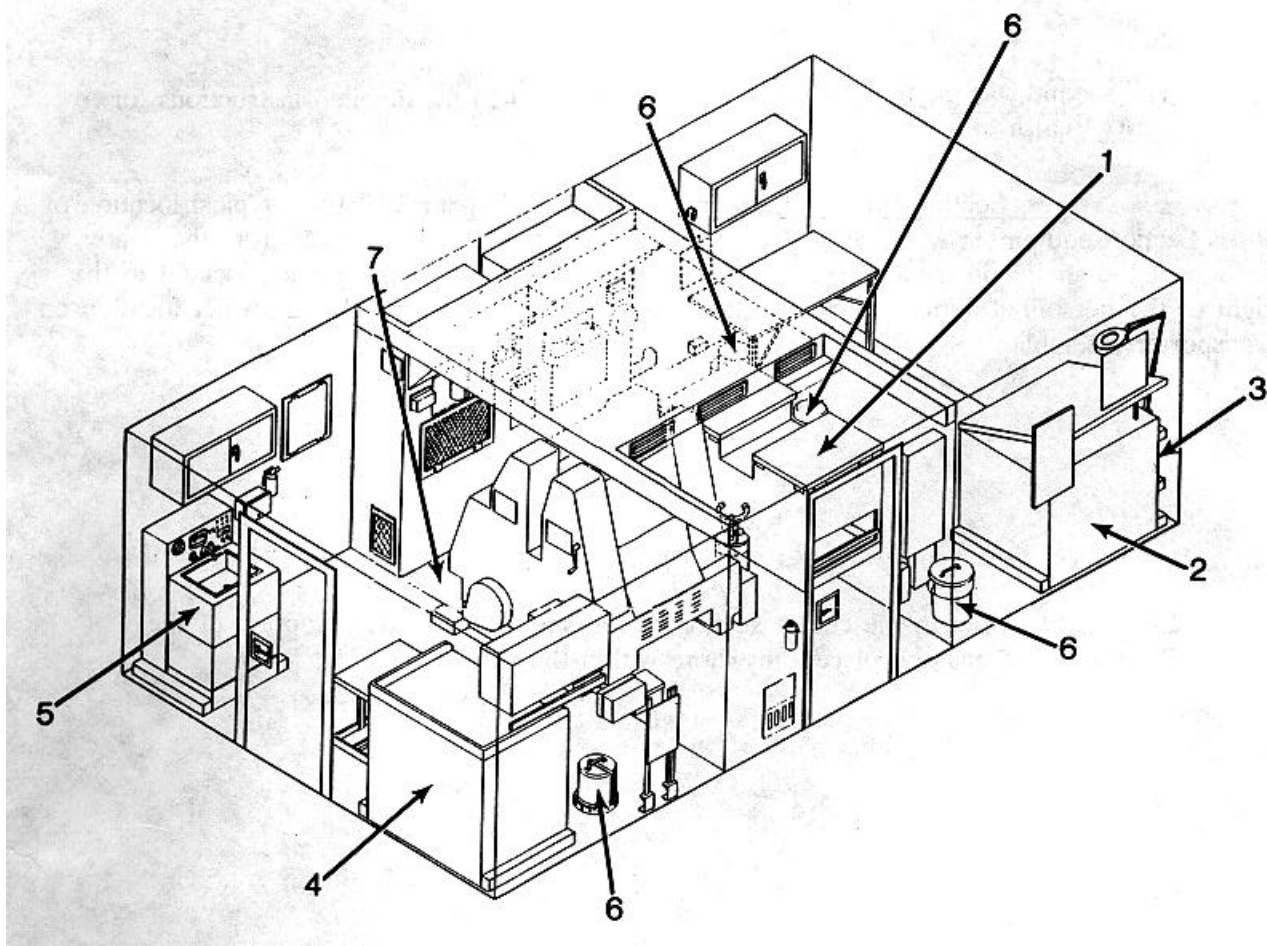

Figure 2-13. Operating Location of Press Section Equipment

2-14. ASSEMBLY AND PREPARATION FOR USE. - Continued

(8) Ceiling lights assemblies. Refer to figure 2-14 and remove ceiling light assemblies (1) from their ceiling storage brackets (2) by rotating safety release bracket (3) and sliding the light assembly over the button to allow the assembly to drop from its mounting stubs. Install the lights onto the expanded shelter section ceilings. Connect electrical cord from each light assembly to the ceiling receptacles. Light storage locations (4) are shown in Figure 2-15.

NOTE

The second storage location from the personnel door also has a safety release button which must be pressed.

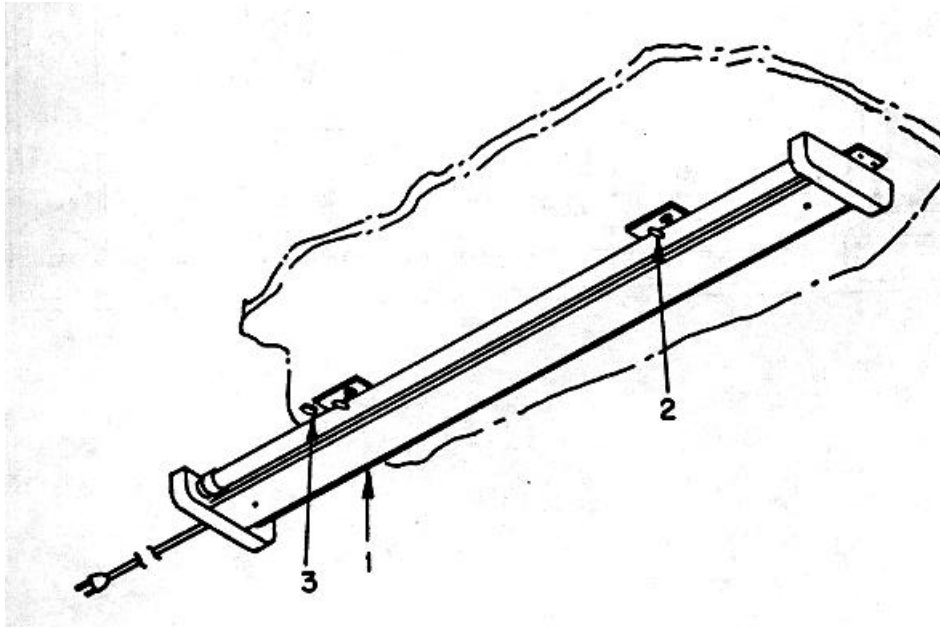

Figure 2-14. Ceiling Light Assembly

2-14. ASSEMBLY AND PREPARATION FOR USE. - Continued

LIGHT STORAGE LOCATION (4)

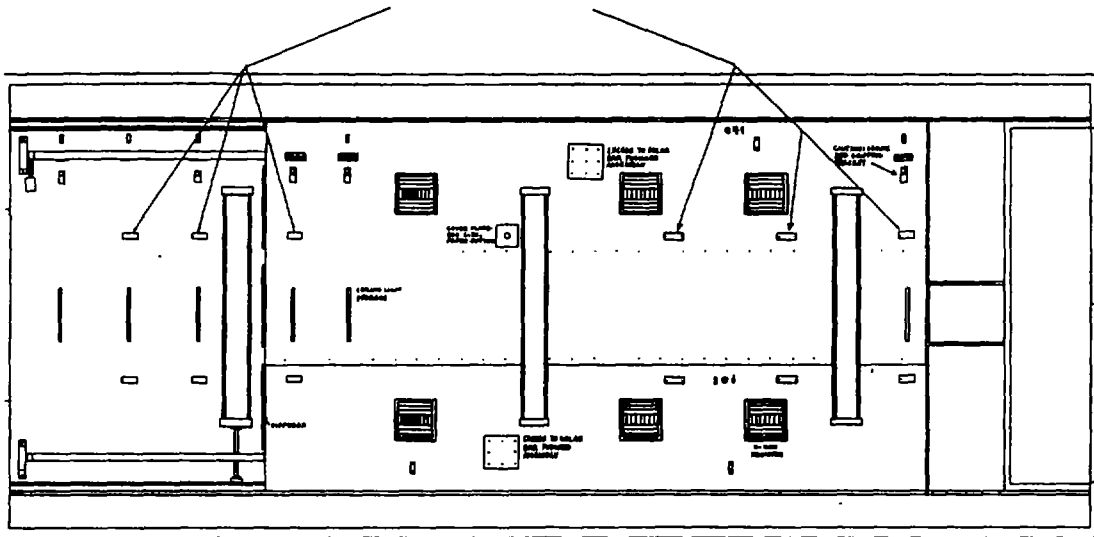

Figure 2-15. Ceiling Light Assemblies, Stored Location, View Looking up at Ceiling

2-14. **ASSEMBLY AND PREPARATION FOR USE.** - Continued

(9) Refer to TM 5-3610-304-10 for setup instructions for the printing press.

d. Connecting Power to Shelter and Power Distribution Box.

CAUTION

Make sure that the main circuit breaker in the Power Distribution Box is in the OFF position before connecting the power cable to the Distribution Box or Shelter. Failure to do so may result in electrical short and damage to equipment.

NOTE

The generator operator will connect the main power cable from the generator set to the Power Distribution Box.

(1) Install grounding rod.

(2) Verify that main circuit breaker CB1 (1) on the Power Distribution Box is in the OFF position. Refer to Figure 2-17 for location of controls and indicators on Power Distribution Box and phase monitor meter.

(3) Connect grounding rod grounding line to shelter ground lug (1, Figure 2-16). Connect power cable to the Press Section receptacle (2, Figure 2-17) on the Power Distribution Box and to the Press Section shelter power input receptacle (2, Figure 2-16).

(4) Notify Module C operator that you have completed connecting your shelter to the Power Distribution Box. Wait until Module C supervisor has set main circuit breaker CB1 on Power Distribution Box to ON position before performing step (5).

2-14. ASSEMBLY AND PREPARATION FOR USE. - Continued

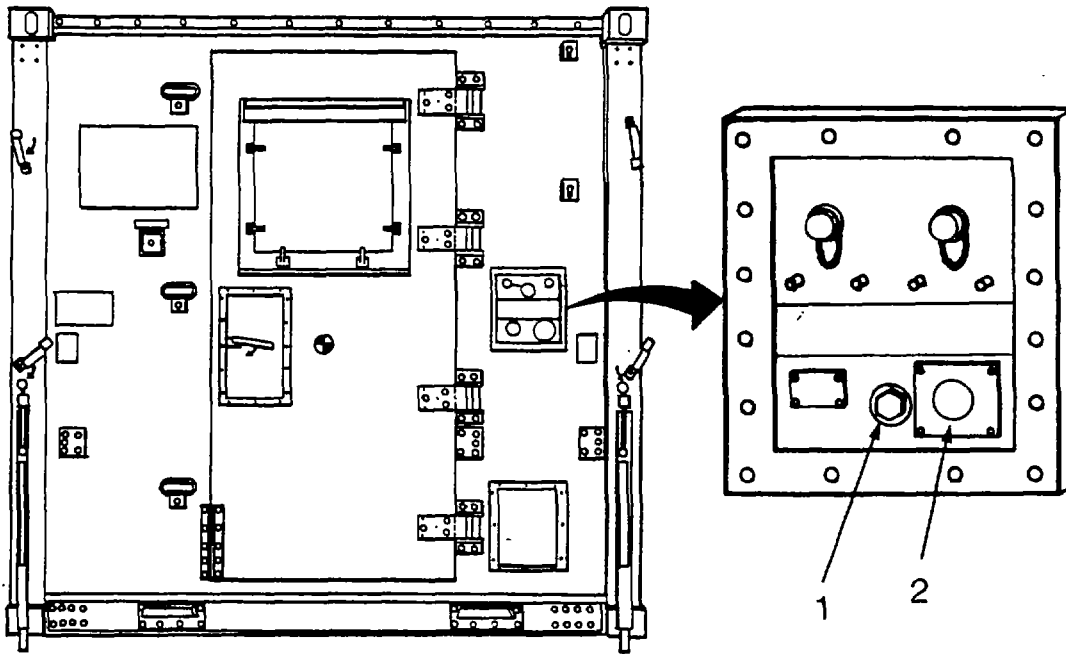

Figure 2-16. Power Cable Connections to Press Section Shelter

- (5) Read voltage meter (3, Figure 2-17) on phase monitor meter. Voltage must read between 110 and 120 Vac on phases A, B, and C.
- (6) Push down test phase switch (4). Correct phase lamp (5) should light.
- (7) Read frequency meter (6). Frequency must read 60 ± 1.0 Hz on phases A, B, and C.
- (8) Place all circuit breakers and switches on the Power Distribution Panel inside the shelter in the ON position.
- (9) Install flexible duct between air conditioner assembly vent and rear shelter wall.

2-14. **ASSEMBLY AND PREPARATION FOR USE.** - Continued

(10) Verify that cargo door vent assemblies are open, and energize air conditioner units and set controls (Heating or Cooling) to desired positions.

(11) Set ON/OFF switch on emergency light to ON position.

(12) Remove cover and refer to the Printing Press Operators manual TM 5-3610-304-10 and energize the Printing Press.

(13) Install passageway tent in accordance with TM 10-5411-203-13.

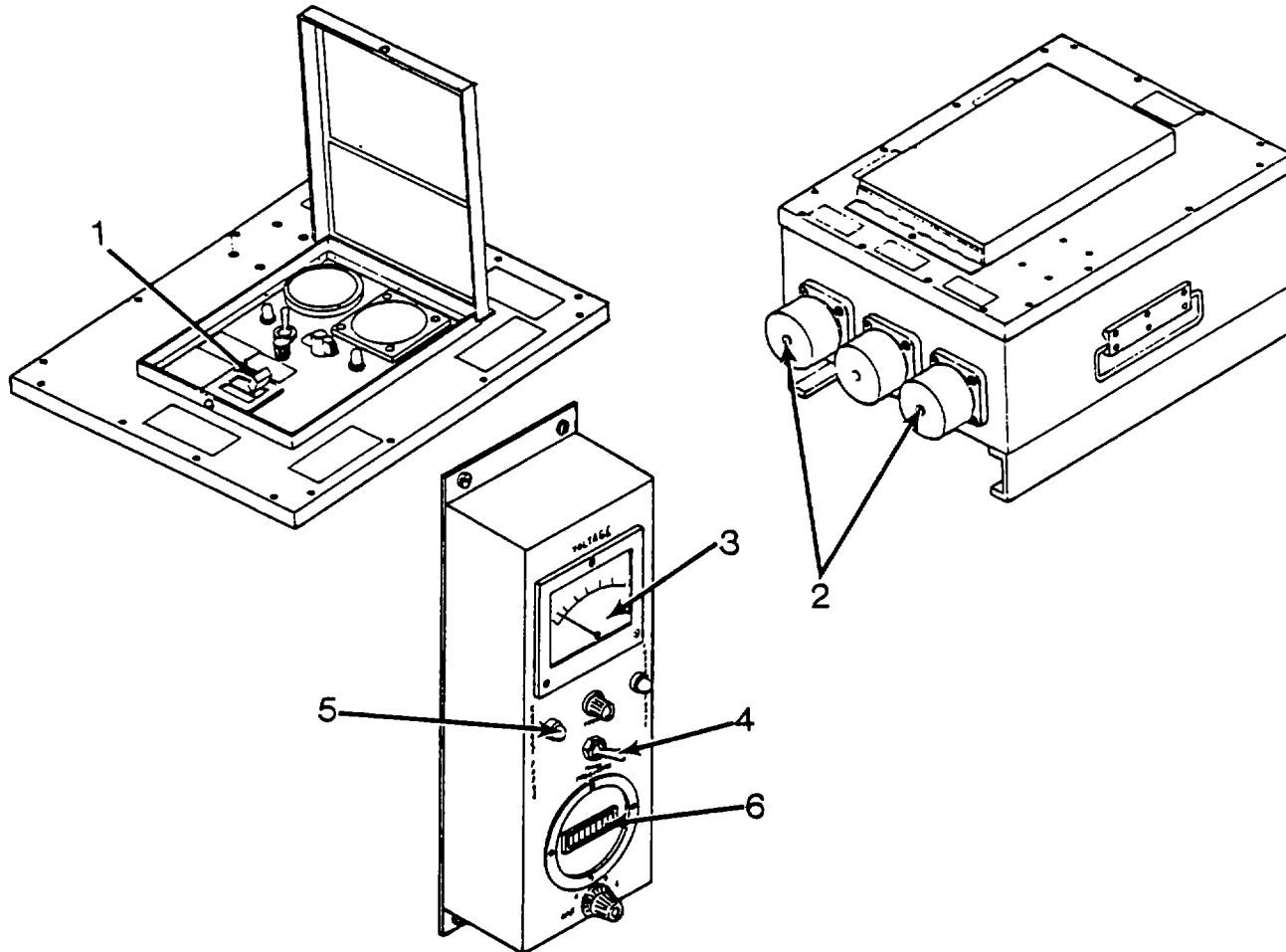

Figure 2-17. Power Distribution Box Controls and Indicators

2-14. **ASSEMBLY AND PREPARATION FOR USE.** - Continuede. Setting Up and Operating Sink Assembly. (See figure 2-18.)

(1) Remove portable pump (1), 25-foot hose (2), and 50-foot hose (3) from storage locations in ink cart and tool caddy assembly.

(2) Place portable pump (1) outside personnel door, connect 25-foot hose (2) to portable pump outlet and connect 50-foot hose (3) to portable pump inlet.

(3) Connect other end of 25-foot hose (2) to sink assembly inlet (4) and connect other end of 50-foot hose (3) to water source.

(4) Verify that all switches are in the OFF position and that sink assembly power cord is connected to wall outlet and place water level switch (5) in FRESH WATER LEVEL position.

(5) Connect portable pump electrical cord to exterior 120v outlet (6) on shelter power input panel.

(6) Open hot water faucet (7), push press to test switch (8), and monitor water level on water level monitor (9). As soon as water level monitor (9) starts indicating, place fresh water pump switch (10) in ON position.

(7) When water starts pouring out of faucet (7), close hot water faucet (7) and open cold water faucet (7). When water starts pouring out of faucet (7), close cold water faucet (7).

(8) When fresh water tank is full (sound level of portable pump (1) will change or sound of water entering fresh water tank will change), disconnect portable pump electrical cord, disconnect 25-foot hose (2) and 50-foot hose (3). Stow portable pump (1) and hoses in ink cart and tool caddy assembly.

CAUTION

If thermometer indicates temperature in hot water tank is above 170°F, place water heater switch in OFF position and notify Unit Maintenance. Failure to do so may result in damage to equipment.

(9) Place water heater switch (11) in ON position. The water heater will take approximately 10 minutes to fully heat the water in the hot water tank. Check thermometer (12). Water temperature should be 160°F or less.

2-14. ASSEMBLY AND PREPARATION FOR USE. - Continued

(10) Operate sink by opening and closing hot and cold water faucet (7) as required. Periodically check fresh water level by pushing press to test switch (8) with water level switch (5) in FRESH WATER LEVEL position to determine when it is necessary to refill the fresh water tank.

NOTE

If fresh water pump starts running continuously, check fresh water tank level. Tank is probably out of fresh water. Before refilling fresh water tank, the gray water tank must be drained.

(11) In preparation for draining gray water tank, place fresh water pump switch (10) in OFF position, connect drain hose (13) to sink assembly drain outlet (14), and connect the other end of drain hose (13) to a suitable container for contaminated fluid disposal. Dispose of container in compliance with Standard Operating Procedures.

(12) Place drain switch (15) in GRAY WATER DRAIN position, place drain pump switch (16) in ON position. Drain until empty. Place drain pump switch (16) in OFF position. Set drain switch (15) to OFF position.

WARNING

The sink assembly rear door must not be opened when power cable is connected. Failure to comply may result in DEATH or serious injury.

NOTE

The following steps are only performed in preparation for movement or repair.

(13) Place water heater switch (11) in OFF position.

(14) Disconnect sink assembly power cable (17) from wall outlet (18). Open rear door (19) and fully open hot water tank drain valve (20).

(15) Close rear door (19), connect sink assembly power cable (17) to wall outlet (18), and place drain switch (15) in FRESH WATER DRAIN position.

2-14. ASSEMBLY AND PREPARATION FOR USE. Continued

(16) Open hot and cold faucets (7) and place drain pump switch (16) in ON position. When hot water tank and fresh water tank are empty, place drain pump switch (16) in OFF position.

WARNING

**The sink assembly rear door must not be opened when power cable is connected.
Failure to comply may result in DEATH or serious injury.**

(17) Place all switches in OFF position, turn off hot and cold faucets (7), and disconnect and stow drain hose (13).

(18) Disconnect sink assembly power cable (17) from wall outlet (18) and open rear door (19). Fully close hot water tank drain valve (20) and close rear door (19).

2-14. ASSEMBLY AND PREPARATION FOR USE. Continued

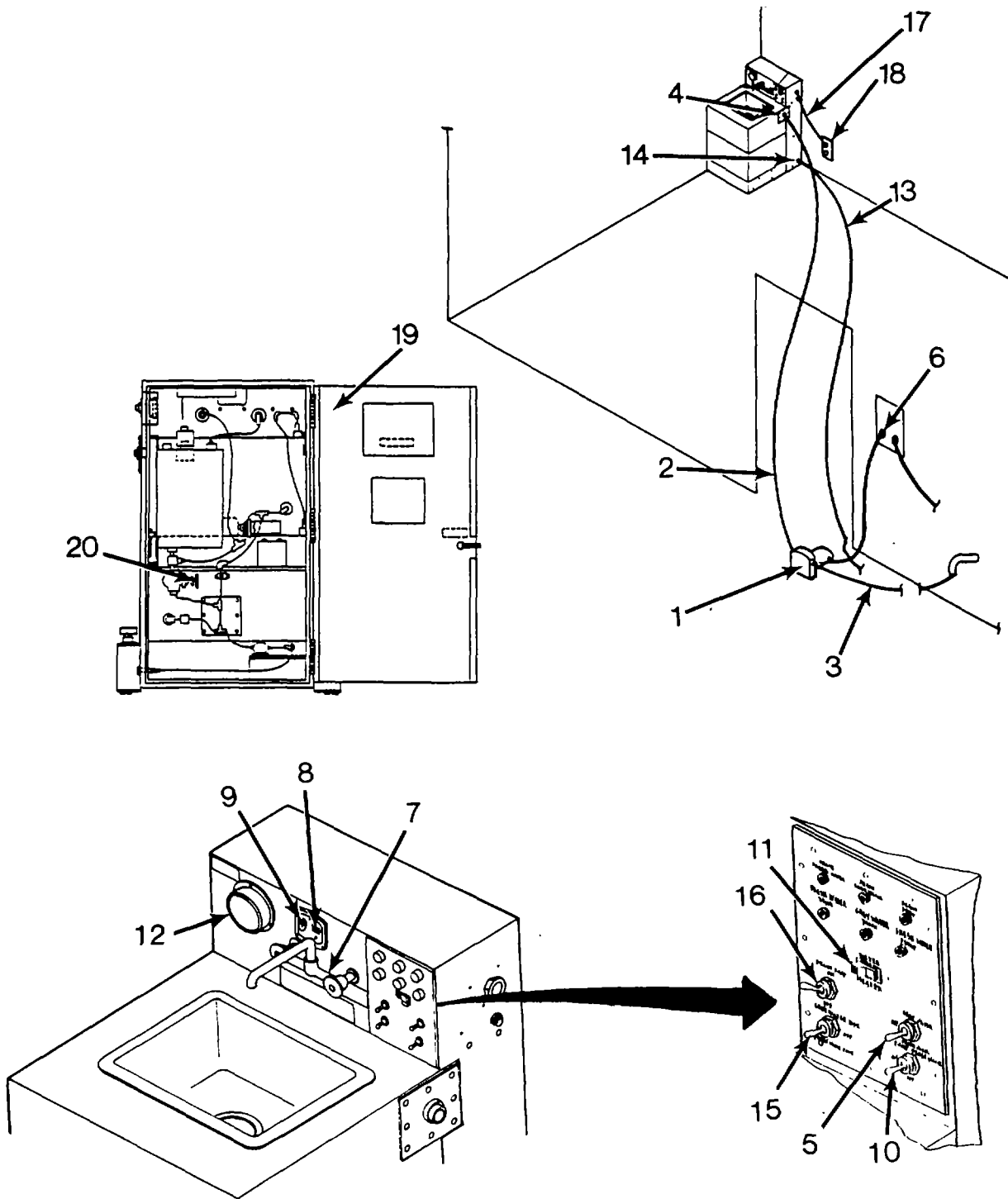

Figure 2-18. Setting Up Sink Assembly

2-15. PREPARATION FOR MOVEMENT.**WARNING**

Never connect or disconnect any power cables when electrical power is energized to the cables. Failure to do so will result in damage to equipment and/or serious injury or DEATH to personnel.

- a. Place all ON/OFF power switches on all operating equipment in the shelter in the OFF position.
- b. Place all circuit breakers and switches on the Power Distribution Panel in the shelter in the OFF position.
- c. Notify Module C operator that you are ready for the main circuit breaker CB1 on the Power Distribution Box to be put in the OFF position. Wait until Module C operator has put the Power Distribution Box main circuit breaker CB1 in the OFF position before performing step d.
- d. Disconnect power cable between the Power Distribution Box and the Press Section shelter. Roll power cable and place in storage compartment behind cargo doors under AC units. Disconnect grounding rod wire, remove grounding rod, and stow in storage rack.
- e. Drain lubricating oil from side covers of printing press (Refer to TM 5-4210-304-10). Spray unpainted surfaces with lubricant (Appendix E, item 22). Place cover on printing press.
- f. Return all tools, and materials and other small items to their proper storage locations.
- g. Secure all cabinet and storage compartment doors.
- h. Unplug electrical cords of the ceiling fluorescent light assemblies in the expanded sections of the shelter. Remove light assemblies by depressing the safety release button, sliding the light assemblies in their overhead storage locations in the center section of the shelter and secure their electrical cords in their storage clips. Secure light assemblies with safety release brackets.

NOTE

Each equipment item to be stowed in the shelter center section is marked with a colored dot. There is a corresponding colored dot on the shelter ceiling and floors. Items are to be stored in the order listed below by matching the colored dot on the equipment with its matching colored dot in the floor and ceiling of the shelter center section.

2-15. PREPARATION FOR MOVEMENT. Continued

For each equipment item with transporter, raise equipment with transporters, move to storage location, lower to floor, and secure with retainer bolts.

- i. Refer to Figure 2-19 and stow equipment in the following order.
 - (1) Roll up floor mat and place in storage location.
 - (2) Place ink cart and tool caddy with black dot in position over black dot on shelter floor.
 - (3) Place the GTO Cabinet Assembly with red dot beside the ink cart and tool caddy with red dot, and under the red dot in the shelter ceiling.
 - (4) Place the work transfer cart with the yellow dot in position over the yellow dot on the shelter floor.
 - (5) Drain the sink assembly storage tanks and place the sink assembly with blue dot in position over the blue dot on the shelter floor.
 - (6) Place paper jogging cabinet assembly with brown dot in position over the brown dot on the shelter floor.
 - (7) Stow roller wash racks under folding table, unlatch braces, and fold down folding table.
 - (8) Place stools, tool box and waste can in storage locations shown in Figure 2-19 and secure in place with stretch cords.
- j. Disconnect passageway tents between the Press Section Shelters and the Finishing Section Shelter. Refer to TM 10-5411-203-13 for disassembly procedures.
- k. Strike the Press Section Shelters. Refer to TM 10-5411-200-14 for striking procedures.

2-15. PREPARATION FOR MOVEMENT. Continued

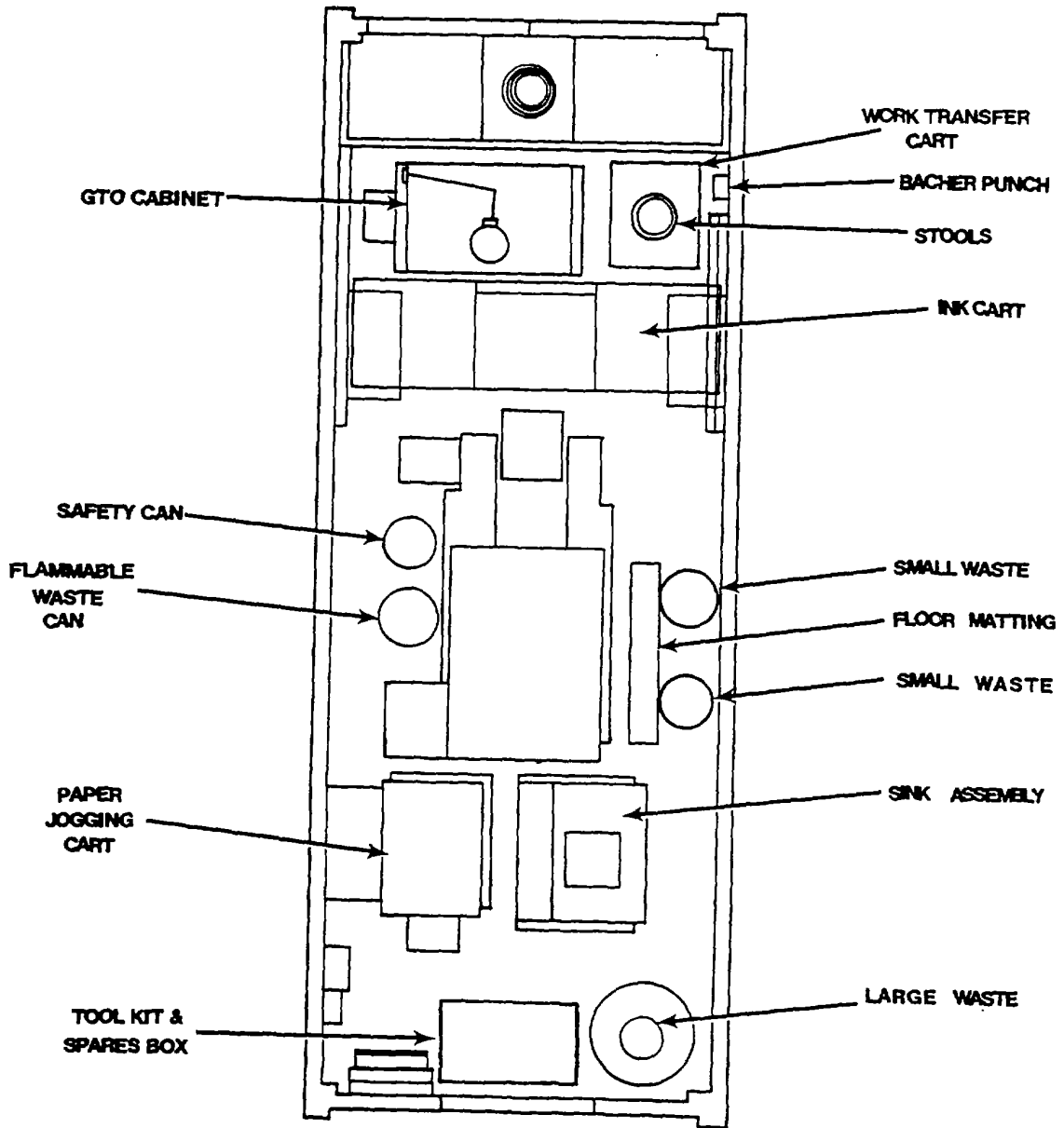

Figure 2-19. Press Section Equipment Storage Location

2-16. OPERATING INSTRUCTIONS ON DECALS. Figures 2-20 through 2-25 below identify warnings, cautions and data plate decals on equipment in the Press Section.

- a. Power Distribution Panel. Circuit breaker and switch numbers are listed on an index card on the inside of the door.

PANEL BOARD	
120/208V	PH. 3 DATE:
FED FROM PANEL	
CIR	LOAD DESCRIPTION
1	AIR CONDITIONER/HEATER 36000 BTU
2	AIR CONDITIONER/HEATER 24000 BTU
3	OUTLETS J-18, J-19, J-20
4	PRINTING PRESS
5	OUTLETS J-12 THRU J-17, J-25
6	CEILING LIGHTS BLACKOUT BUZZER
7	OUTLETS J-21, J-22, J-23, J-24; AC ROOM LIGHT
8	EXTERIOR OUTLETS (GROUND FAULT)
9	SPARE
10	
11	SPARE
12	
13	SPARE
14	

Figure 2-20. Power Distribution Panel Data Index Card

2-16. OPERATING INSTRUCTIONS ON DECALS. Continued

b. Sink Assembly. Figure 2-21 below identifies decals on the Sink Assembly.

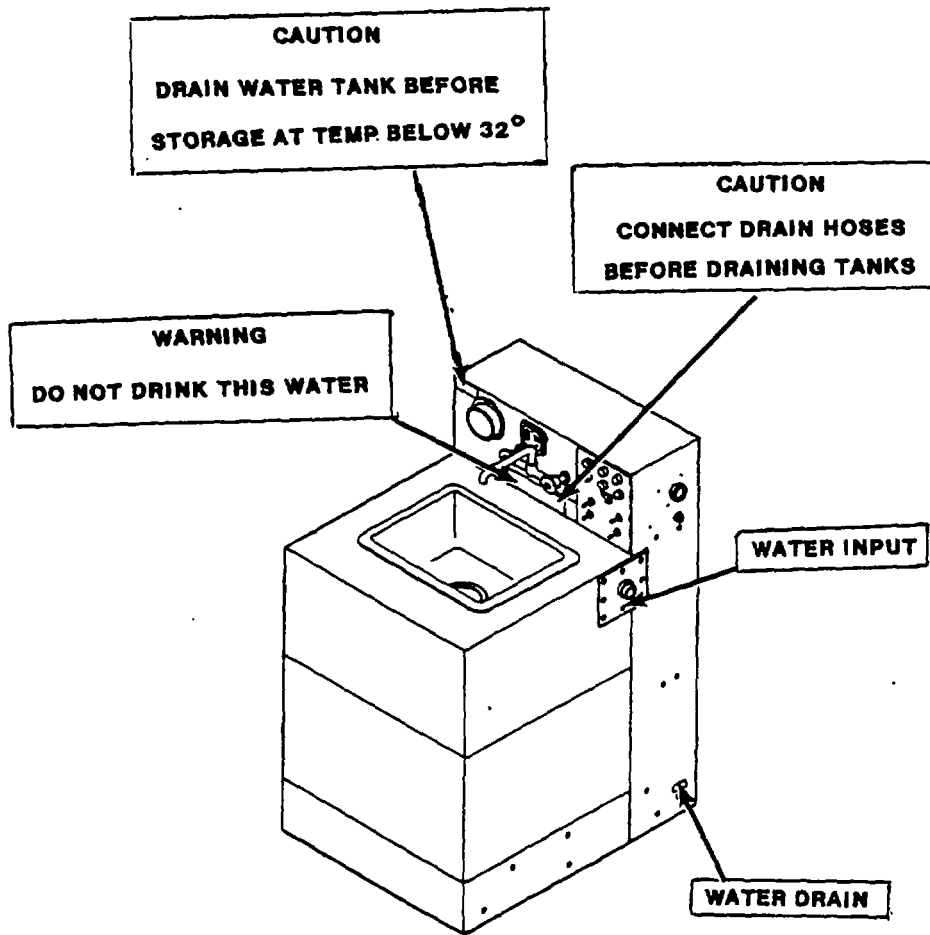

Figure 2-21. Sink Assembly Decal Locations

2-16. OPERATING INSTRUCTIONS ON DECALS - Continued

c. Ink Cart and Tool Caddy Assembly. Figure 2-22 below identifies decals on the Ink Cart and Tool Caddy Assembly.

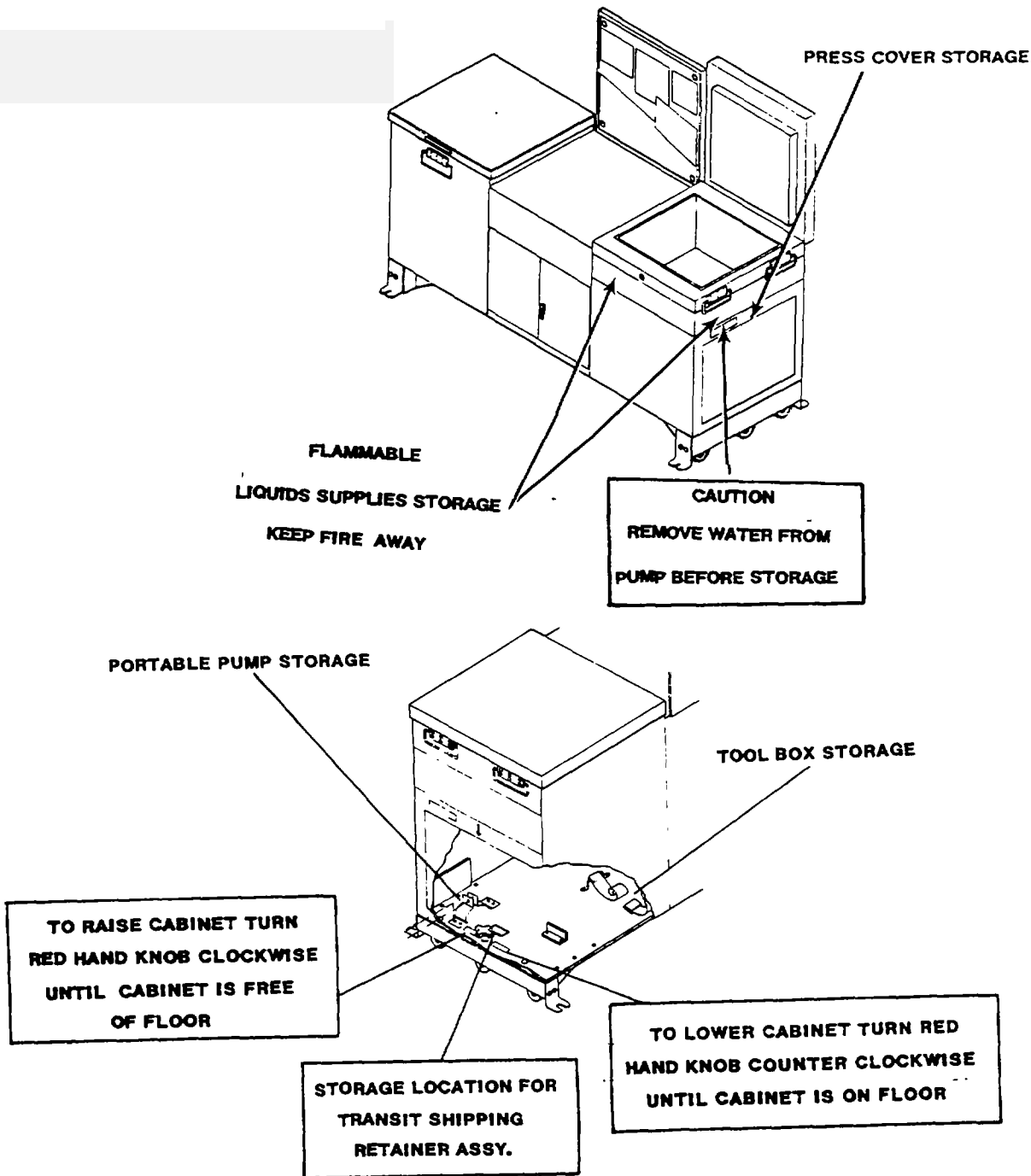

Figure 2-22. Ink Cart and Tool Caddy Assembly Decal Locations

2-16. OPERATING INSTRUCTIONS ON DECALS. Continued

d. Printing Press. Figure 2-23 below identifies decals added to the printing press.

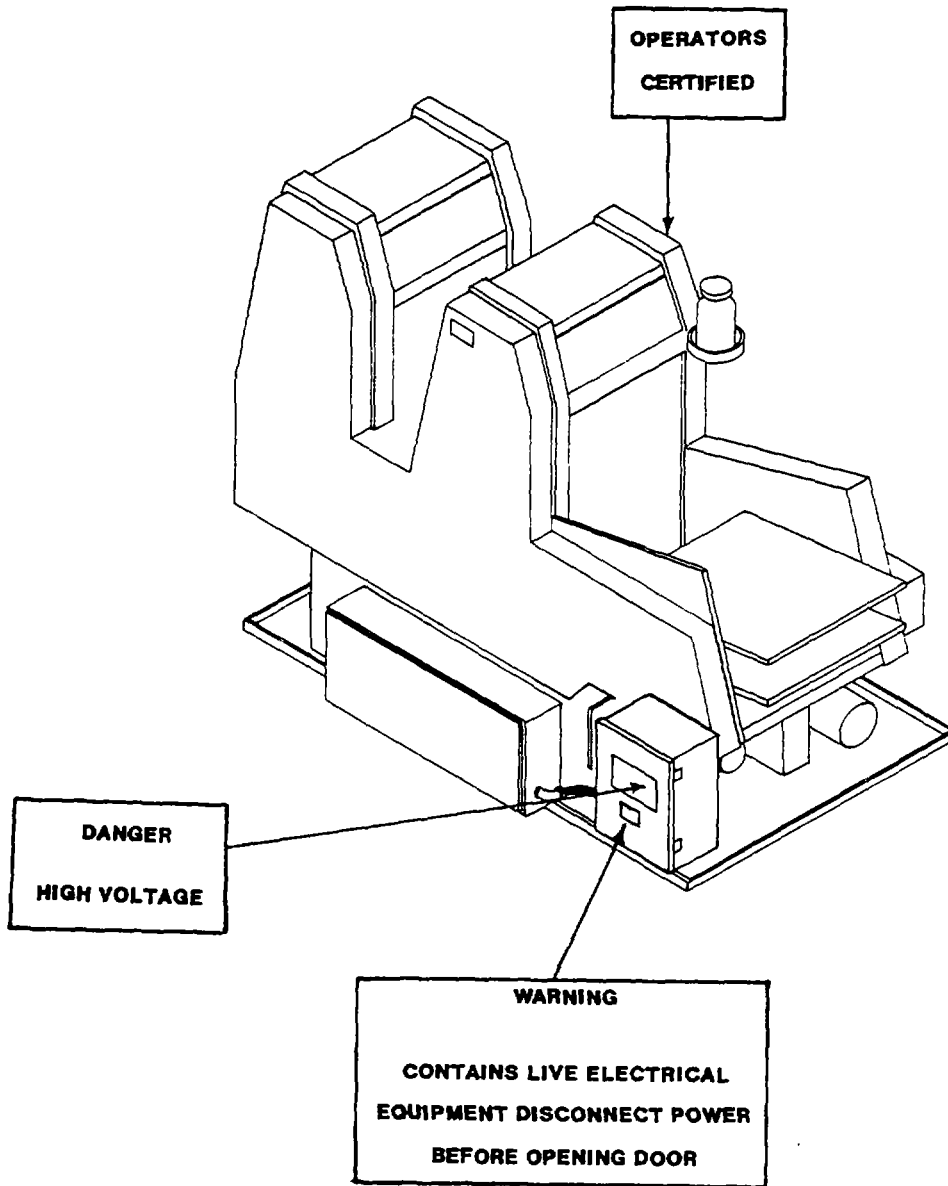

Figure 2-23. Printing Press Decal Locations

2-16. OPERATING INSTRUCTIONS ON DECALS. Continued

- e. Transporter Assembly. Figure 2-24 below identifies decals on the transporter assembly.

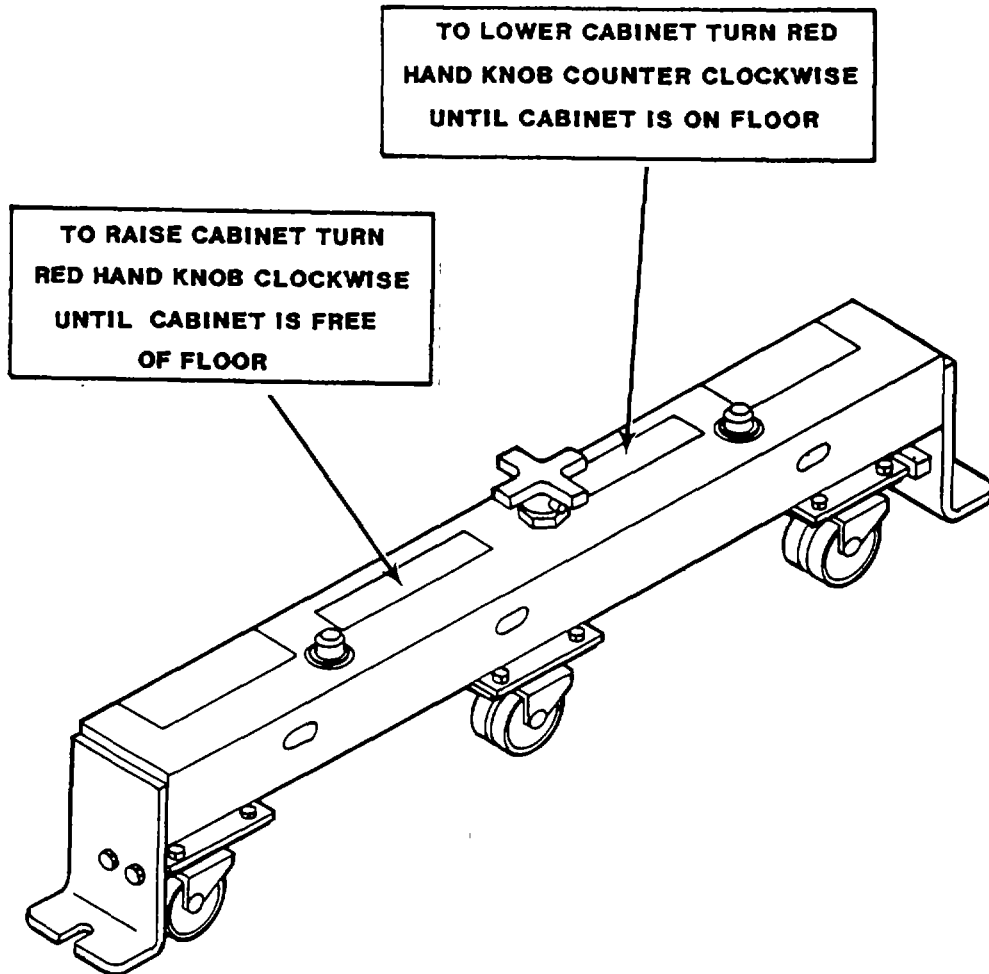

Figure 2-24. Transporter Assembly Decal Locations

2-16. OPERATING INSTRUCTIONS ON DECALS. Continued

f. Shelter. Figure 2-25 below identifies decals added to the shelter.

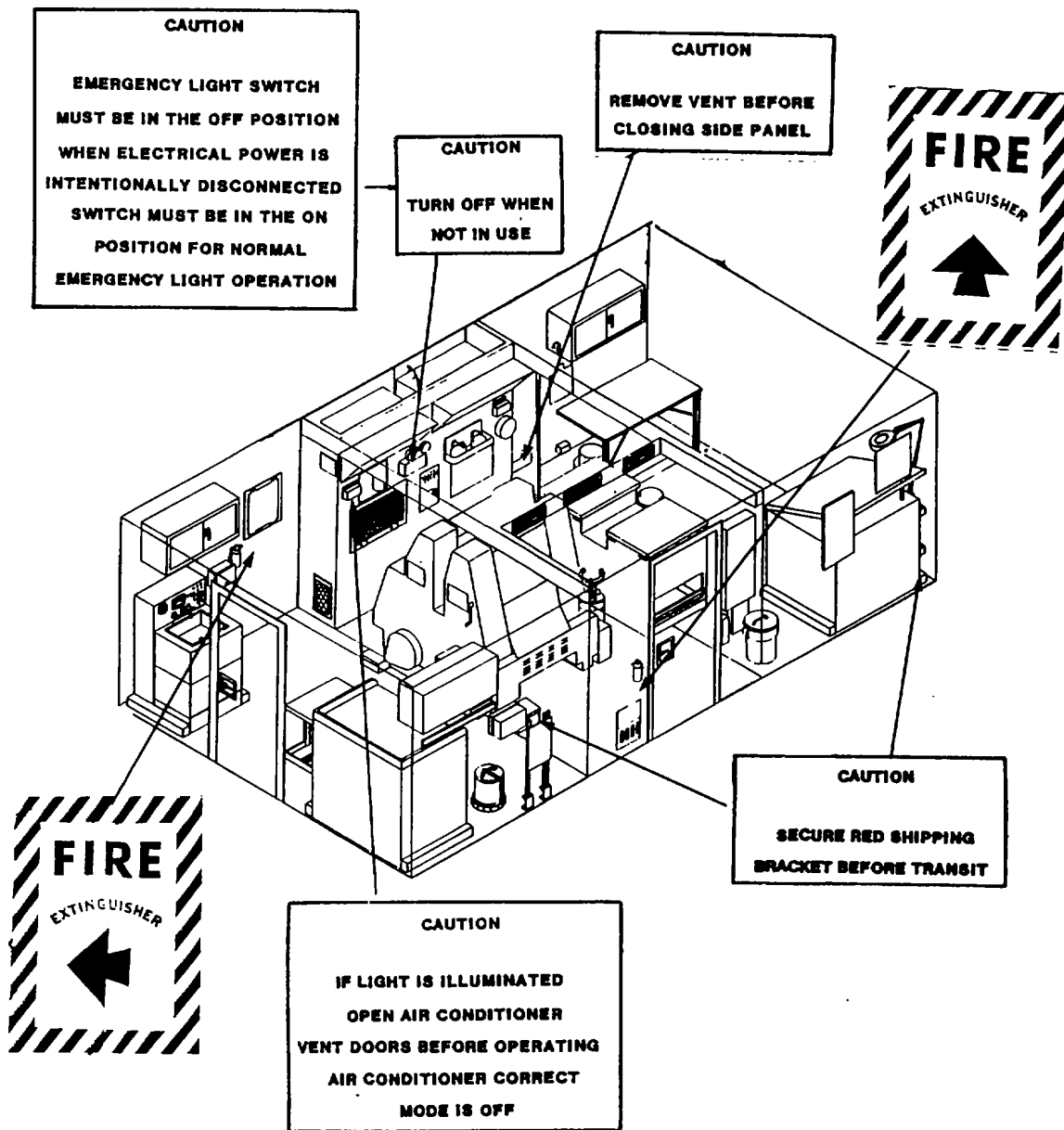

Figure 2-25. Shelter Decal Locations

SECTION IV. OPERATION UNDER UNUSUAL CONDITIONS**2-17. OPERATION IN EXTREME COLD.****WARNING**

In extreme cold, do not touch metal parts with bare hands. Severe skin damage may result.

- a. Shelter. Refer to TM 10-5411-200-14 for general operation of the shelter in ice, snow or extreme cold.
- b. Internal Operation. The Press Section is normally operated with the AC units energized and is therefore not affected by the outside temperature.
- c. External Power Cable. The main power cable and grounding cables will become hard, brittle and difficult to handle in extreme cold. Do not allow cables to kink resulting in permanent damage.
- d. Connector Receptacles. Ensure that cable connectors and receptacles are free from frost, snow or ice.
- e. Liquid Supplies. Remove all liquids from the shelter when the heaters are not operating or when preparing the shelter for transport. Containers may freeze and break and damage internal equipment or paper supplies.

2-18. OPERATION IN EXTREME HEAT.

- a. Consumable Supplies. Protect consumable supplies from extreme heat to prevent reduced shelf-life.
- b. Internal Components. Frequently inspect gaskets, seals and insulation for deterioration.

2-19. OPERATION IN TROPICAL CONDITIONS.

- a. Heat and Humidity Control. Keep doors closed and ensure that AC units are operating properly.
- b. Internal Equipment and Supplies. Inspect equipment, documents and supplies frequently for signs of fungi, mildew or mold.

2-20. OPERATION IN DESERT CONDITIONS.

a. Shelter Interior. Use extreme care to prevent dust, grit or sand from entering the shelter. Vacuum and dust frequently to protect equipment and supplies.

b. AC Unit Filters. Inspect air filters frequently and clean or change as necessary.

CHAPTER 3. OPERATOR MAINTENANCE

SECTION I. LUBRICATION INSTRUCTIONS

3-1. **GENERAL.** Lubrication of equipment of the Press Section is mandatory and must be performed routinely to keep equipment in operation. The following paragraphs describe operator lubrication instructions.

3-2. **PRINTING PRESS.** Refer to TM 5-3610-304-10 and TM 5-3610-304-20 for lubrication instructions.

3-3. **AIR CONDITIONERS (24,000 BTUH AND 36,000 BTUH).** Refer to figure 3-1. Lubricate hinges (1) on all air vent doors using lubricant (Appendix E, item 22). Wipe off excess lubricant. Refer to TM 5-4120-395-14&P for detailed lubrication instructions on the 24,000 BTUH Air Conditioner and to TM 5-4120-396-14&P for detailed lubrication instructions on the 36,000 BTUH Air Conditioner.

3-3. AIR CONDITIONERS (24,000 BTUH AND 36,000 BTUH). - Continued

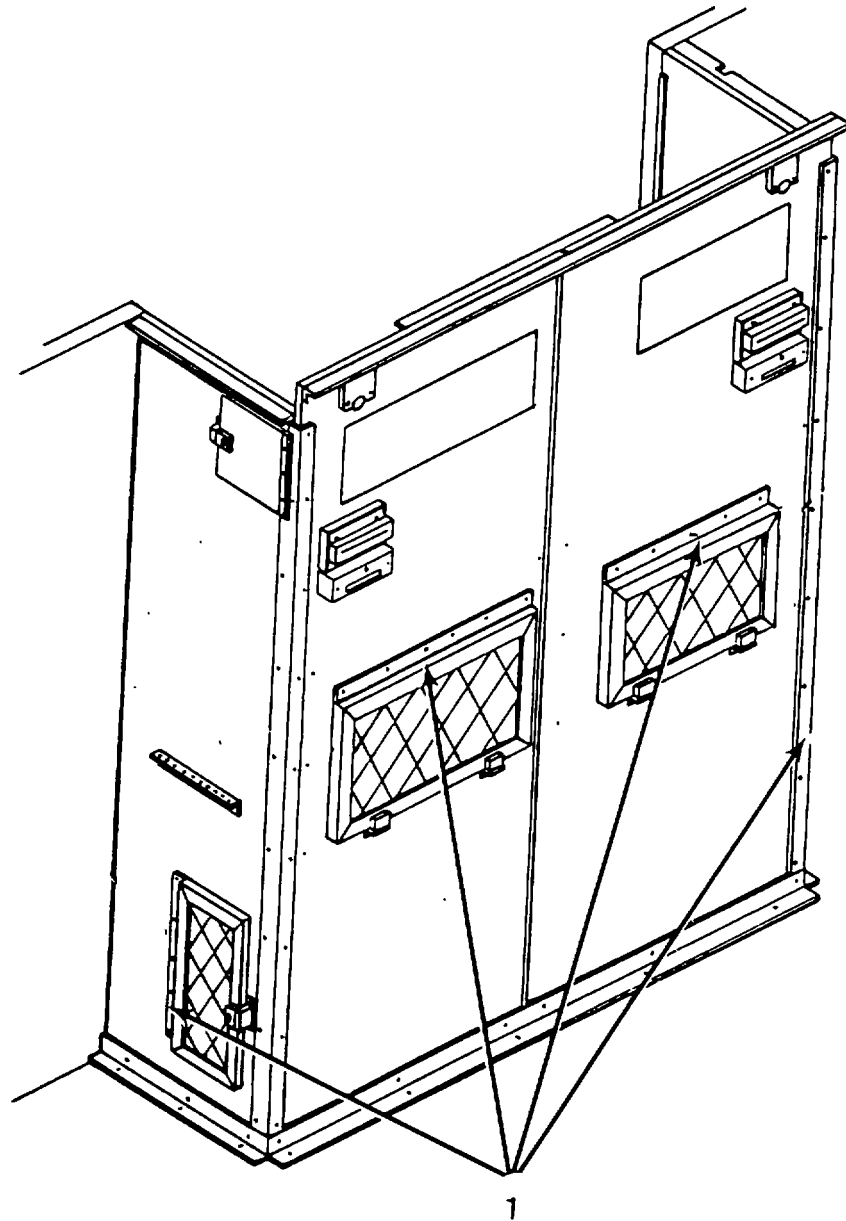

Figure 3-1. Air Conditioner Air Vent Doors Hinges.

3-4. **CARGO DOORS AC VENT ASSEMBLIES.** Refer to figure 3-2. Lubricate hinges (1) on cargo doors AC vent assemblies (2) with lubricant (Appendix E, item 22). Wipe off excess lubricant.

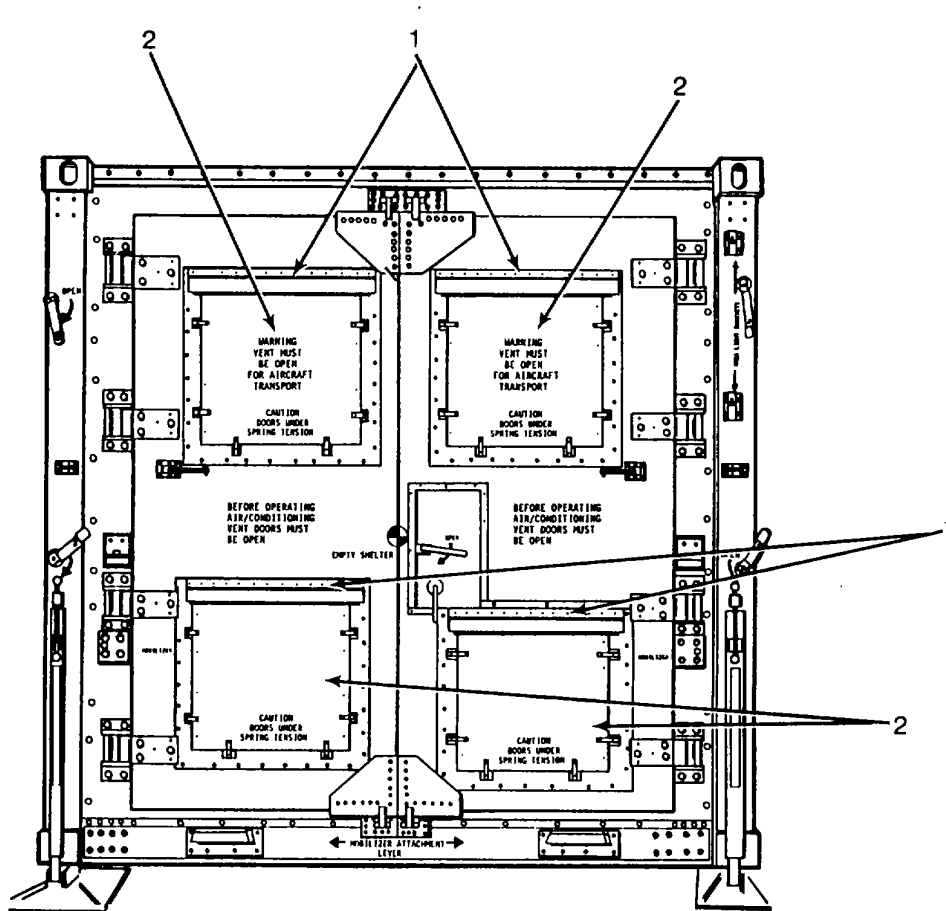

Figure 3-2. Cargo Doors AC Vent Assemblies

3-3/(3-4 Blank)

SECTION II. OPERATOR TROUBLESHOOTING PROCEDURES

3-5. GENERAL.

a. This section contains troubleshooting information for locating and correcting most malfunctions of the Press Section. Each malfunction for an individual component or unit is followed by a list of tests or inspections which will help you to determine corrective actions in order listed.

b. This manual cannot list all malfunctions that may occur, nor all tests or inspections and corrective actions. If a malfunction is not listed, or is not corrected by listed corrective actions, notify your supervisor.

c. Table 3-1 lists the common malfunctions which you may find during operation of the Press Section or its components. You should perform tests or inspections and corrective actions in the order listed.

d. Refer to paragraphs 3-1 through 3-4 for lubrication instructions.

WARNING

High voltage exists in the electrical components of this equipment. DEATH on contact may result if personnel fail to observe safety precautions.

NOTE

If you suspect a problem, you should first verify that the start-up procedures have been properly performed before continuing with troubleshooting.

3-5. GENERAL. - Continued

Table 3-1. Operator Troubleshooting

MALFUNCTION	TEST OR INSPECTION	CORRECTIVE ACTION
-------------	--------------------	-------------------

1. AIR CONDITIONER DUCTING ASSEMBLY DOES NOT CONTROL AIR FLOW.

Step 1. Ensure that duct vents are adjusted for desired air flow.

Adjust duct vents, as necessary.

Step 2. Check for damaged or broken vent doors.

Notify unit maintenance of trouble.

2. AIR CONDITIONER HOUSING ASSEMBLY DOES NOT OPERATE PROPERLY.

Step 1. Check vent doors for ease of operation.

Lubricate vent doors.

Step 2. Check housing for general condition (dents, gouges, or broken hinges.)

Notify unit maintenance of trouble.

3. AIR CONDITIONER ASSEMBLY (24,000 AND 36,000 BTUH) DOES NOT OPERATE.

Step 1. Verify that AC circuit breaker is on at the power distribution panel.

Step 2. Check temperature set point lever for proper temperature setting and heat/cool switch setting for COOL or HEAT.

Set heat/cool switch on thermostat to desired setting (HEAT or COOL) and adjust temperature set point lever.

Step 3. Check air conditioner vents on cargo door vent assemblies.

Open air conditioner vents.

3-5. GENERAL. - Continued

Table 3-1. Operator Troubleshooting - Cont

MALFUNCTION	TEST OR INSPECTION	CORRECTIVE ACTION
-------------	--------------------	-------------------

Step 4. Verify that AC dampers are open.

Open AC dampers.

Step 5. If steps 1 through 4 above are okay, refer to air conditioner technical manuals (TM 5-4120-395-14&P for the 24,000 BTUH AC or TM 5-4120-396-14&P for the 36,000 BTUH AC) for additional trouble-shooting procedures.

4. PRINTING PRESS FAILS TO OPERATE.

Step 1. Check power distribution panel circuit breakers to make sure they are on.

Turn on power distribution panel circuit breakers.

Step 2. Refer to the printing press operation manual (TM 5-3610-304-10) to make sure printing press is set up for operation.

Setup printing press for correct operation.

5. CARGO DOOR VENT ASSEMBLY DOES NOT OPERATE PROPERLY.

Step 1. Check vent doors (4 ea) for proper opening and closing.

Lubricate hinges.

Step 2. Check vent assembly switches for proper operation.

Notify unit maintenance of trouble.

Step 3. Check vent doors for dents or bends and for loose or missing hardware.

Notify unit maintenance of trouble.

3-5. GENERAL. - Continued

Table 3-1. Operator Troubleshooting - Cont

MALFUNCTION	TEST OR INSPECTION	CORRECTIVE ACTION
-------------	--------------------	-------------------

Step 4. Check door latches for proper operations and for broken or missing parts.

Notify unit maintenance of trouble.

6. CEILING LIGHT ASSEMBLY DOES NOT OPERATE.

Step 1. Ensure that fluorescent light bulbs operate when switch in ON.

Replace light bulbs. (Refer to paragraph 3-7.)

Step 2. Check light assembly for dents and for loose or missing hardware.

Notify unit maintenance of trouble.

Step 3. Check light assembly power cord for frayed or broken insulation.

Notify unit maintenance of trouble.

7. SINK ASSEMBLY DOES NOT OPERATE PROPERLY.

Step 1. Check operator controls and indicators for proper operation and for loose or missing hardware.

Notify unit maintenance of trouble.

Step 2. Inspect sink assembly power cord for frayed or broken insulation.

Notify unit maintenance of trouble.

Step 3. Check transporter assembly for ease of operation.

Lubricate transporter assembly wheels.

3-5. GENERAL. - Continued

Table 3-1. Operator Troubleshooting

MALFUNCTION	TEST OR INSPECTION	CORRECTIVE ACTION
-------------	--------------------	-------------------

8. **PASSAGEWAY TENT DOES NOT OPERATE PROPERLY.**

Refer to TM 10-5411-203-13 for operator troubleshooting procedures.

9. **ISO SHELTER DOES NOT OPERATE PROPERLY.**

Refer to TM 10-5411-200-14 for operator troubleshooting procedures.

10. **PHASE MONITOR METER DOES NOT OPERATE PROPERLY.**

Notify unit maintenance of trouble.

SECTION III. OPERATOR MAINTENANCE PROCEDURES

3-6. **GENERAL.** Operator maintenance includes routine lubrication of units and components of the Press Section and replacing of filters and fluorescent light bulbs. If further maintenance is required, notify your supervisor.

3-7. CEILING LIGHT ASSEMBLY.

This task covers: Repair (Refer to figure 3-3).

INITIAL SETUP**Tools**

None

Materials

Fluorescent light bulb

WARNING

This fixture contains voltage that is dangerous if contacted. Before replacing ceiling lights, make sure electrical power is disconnected to the fixture. DEATH on contact may result if this warning is not followed.

WARNING

In the event of fluorescent lamp breakage, care must be taken in the removal of broken glass fragments and white phosphorous dust. Inhalation of phosphorous dust could cause serious injury.

a. Remove light bulb (1) and safety cover (2) by pulling split safety ring (3) apart and sliding over bulb. Push bulb (1) toward end with split safety ring (3) until other end of bulb (1) releases. Remove end cap (4). Slide bulb (1) out of safety cover (2) and replace with new bulb (1).

3-7. CEILING LIGHT ASSEMBLY. - Continued

NOTE

End of light bulb and safety cover with split safety ring must go in end of ceiling light assembly with spring.

b. Install light bulb (1) into safety cover (2) and replace end cap (4). Insert end with split safety ring (3) into spring end of ceiling light assembly and press toward spring end until other end of light bulb (1) and safety cover (2) seats. Install split safety ring (3).

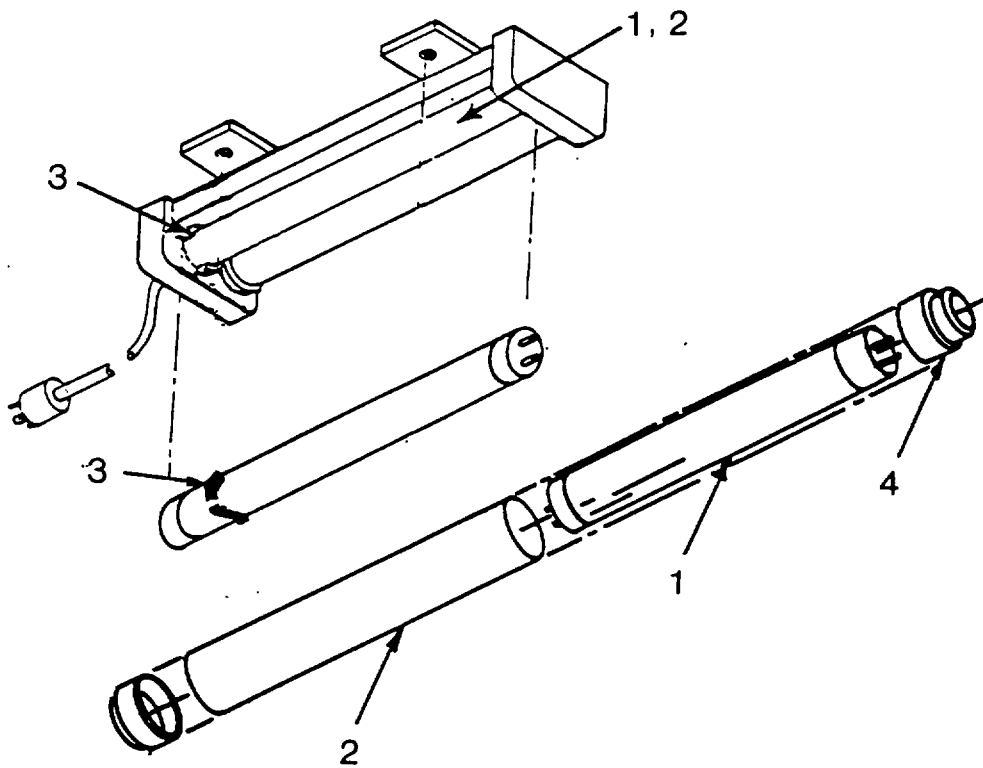

Figure 3-3. Ceiling Light Assembly

3-8. REPLACING INTERIOR AC FILTERS.

This task covers: Repair (Refer to figure 3-4.)

INITIAL SETUP

Tools

None

Materials

AC Filters

- a. Open AC vent door (1).
- b. Remove filter (2).
- c. Install new filter (2).
- d. Close and secure AC vent door (1).

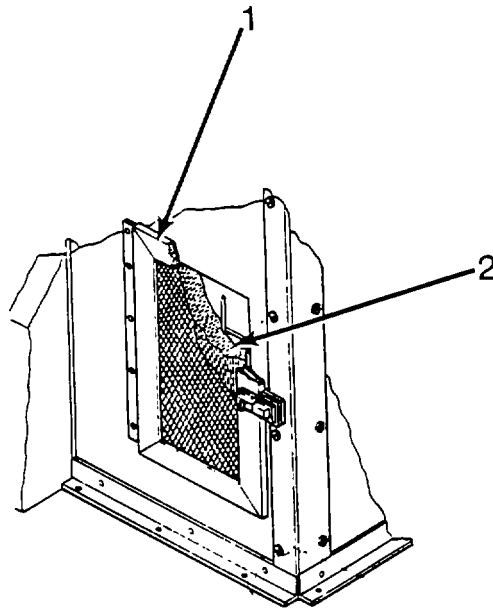

Figure 3-4. AC Filters

3-9. CARGO DOOR VENT ASSEMBLY FILTERS.

This task covers: Repair (Refer to figure 3-5.)

INITIAL SETUP

Tools

None

Materials

Air Filter

- a. Remove screws (1), lockwashers (2), flat washers (3), and vent door (4).
- b. Remove filter (5).
- c. Install new filter (5).
- d. Position vent door (4) and secure with flat washers (3), lockwashers (2), and screws (1).

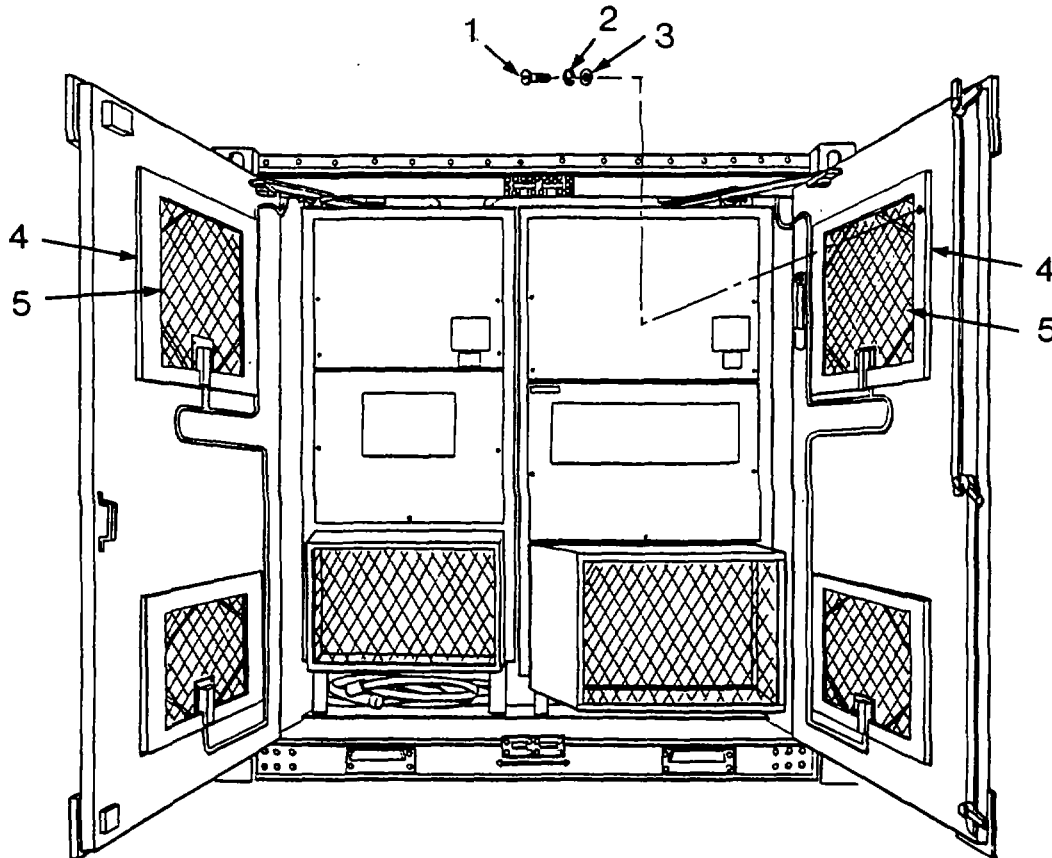

Figure 3-5. Cargo Door Vent Filters

CHAPTER 4. UNIT MAINTENANCE

SECTION I. UNIT LUBRICATION INSTRUCTIONS

4-1. **GENERAL.** There are no lubrication procedures performed by unit maintenance. All routine lubrication of the Press Section is performed by the operator.

**SECTION II. REPAIR PARTS, SPECIAL TOOLS, TMDE
AND SUPPORT EQUIPMENT**

4-2. COMMON TOOLS AND EQUIPMENT.

- a. Appendix B, Section III contains the authorized common tools.
- b. For authorized equipment, refer to the Modified Table of Organization and Equipment (MTOE) applicable to your unit.

4-3. SPECIAL TOOLS, TMDE AND SUPPORT EQUIPMENT.

- a. A special tool, hand blind riveter, Appendix B, Section III, item 5 is used for general riveting using blind rivets.
- b. General mechanics automotive tool kit, Appendix B, Section III, Item 1 is used to repair all mechanical parts in the shelter.
- c. Electrical tool kit, Appendix B, Section III, Item 2 is used to repair wiring.
- d. Multimeter, Appendix B, Section III, Item 3 is used to perform all continuity/voltage tests on the Press Section.
- e. Pipe wrench, Appendix B, Section III, Item 4 is used to repair the sink assembly.

4-4. REPAIR PARTS. Repair parts covering unit maintenance for the Press Section are listed and illustrated in Appendix F of this manual.

SECTION III. SERVICE UPON RECEIPT OF EQUIPMENT

4-5. **SETUP OF SHELTER.** Refer to TM 10-5411-200-14 for shelter setup procedures.

4-6. **SHELTER INVENTORY CHECK.** Refer to TM 10-5411-200-14 for general shelter inventory checks.

4-7. SHELTER AND PRESS SECTION INSPECTION CHECKLIST.

a. Shelter Checklist. Refer to TM 10-5411-200-14 for shelter inspection checklist.

b. Press Section Checklist. Table 4-1 below lists items in the Press Section that must be checked and the action required.

Table 4-1. Press Section Checklist

ITEM	ACTION
1. Power Distribution Panel	Check circuit breakers and switches for damages or loose hardware.
2. Emergency Light	Check for damaged or broken lights or switches.
3. Hygrometer	Check for broken indicators or glass cover.
4. Islatrol Control Box	Insure that it is secure and no hardware is loose or missing.
5. Printing Press	Refer to TM 5-3610-304-20 for inspection and check list procedures.
6. Phase Monitor Meter	Inspect switches, lights and indicators for damages.
7. Thermostat	Inspect for damaged cover or broken indicators.
8. AC Units	Inspect switches, controls and vent filter assemblies for damages.

4-7. SHELTER AND PRESS SECTION INSPECTION CHECKLIST. - Continued

Table 4-1. Press Section Checklist - Continued

ITEM	ACTION
9. AC Ceiling Duct Assembly	Check for damaged air flow vents and levers.
10. Ceiling Light Assemblies	Check for loose or broken bulbs or missing hardware.
11. Cargo Door Vent Assemblies	Check for damages and operation.
12. Sink Assembly	Check housing, control panel door and operator controls and indicators for damages.
13. Ink Cart and Tool Caddy	Check for damaged or loose hardware or missing tool kit or portable pump.
14. GTO Cabinet	Check for damaged or loose hardware.
15. Paper Jogging Cabinet	Check for damaged or loose hardware.
16. Work Transfer Cart	Check for damaged or loose hardware.

SECTION IV. UNIT PREVENTIVE MAINTENANCE CHECKS AND SERVICES (PMCS)

4-8. **GENERAL.** There are no preventive maintenance checks and services (PMCS) at unit level maintenance.

SECTION V. UNIT TROUBLESHOOTING

4-9. **GENERAL.** This section contains unit troubleshooting information for locating and correcting common malfunctions which may develop in the Press Section.

WARNING

The Press Section contains voltages that are dangerous if contacted. When troubleshooting, observe all safety warnings and precautions. Make sure power is disconnected before replacing or repairing electrical components. Failure to do so may result in serious electrical shock or DEATH.

Each malfunction for an individual component is followed by a list of tests or inspections which will help you to determine corrective actions in order listed. This manual cannot list all malfunctions that may occur, nor all tests or inspections and corrective actions. If a malfunction is not listed, or is not corrected by listed corrective actions, notify direct support maintenance.

4-10. **UNIT TROUBLESHOOTING.** Table 4-2 lists the common malfunctions which you may find during operation or maintenance of the Press Section or its components. You should perform the tests or inspections and corrective actions in the order listed.

NOTE

Before you use this table, be sure you have performed applicable Preventive Maintenance Checks and Services.

Table 4-2. Unit Troubleshooting

MALFUNCTION	TEST OR INSPECTION	CORRECTIVE ACTION
-------------	--------------------	-------------------

1. ISLATROL CONTROL BOX ASSEMBLY DOES NOT ALLOW PRINTING PRESS TO OPERATE.

Step 1. Test line terminal board for 208 ± 10 Vac on each phase (A, B, C). (Refer to paragraph 4-12.)

If correct voltage is present, continue with Step 2. If not, check printing press circuit breaker. (Refer to TM 10-5411-200-14.)

If circuit breaker is good, notify Depot Maintenance.

Step 2. Test load terminal board for 208 ± 10 Vac on each phase (A, B, C). (Refer to paragraph 4-12.)

If correct voltage is present, test printing press. (Refer to TM 5-3610-304-20.)

If not, replace islatrol control box. (Refer to paragraph 4-12.)

2. CARGO DOOR VENT ASSEMBLY FAILS TO STAY OPENED OR CLOSED WHEN REQUIRED.

Step 1. Check for loose or missing hardware on door latches or for broken latches.

Tighten or replace hardware.

Replace door latch. (Refer to paragraph 4-13.)

Step 2. Check for broken door spring.

Remove and replace door spring. (Refer to paragraph 4-13.)

4-10. UNIT TROUBLESHOOTING. - Continued

MALFUNCTION**TEST OR INSPECTION****CORRECTIVE ACTION**

Step 3. Test operation of push-button switch. (Refer to paragraph 4-13.)

Remove and replace switch. (Refer to paragraph 4-13.)

Step 4. Check for damaged or broken vent assembly.

Replace vent assembly. (Refer to paragraph 4-13.)

3. AIR CONDITIONER ASSEMBLY DOES NOT OPERATE.

Step 1. Perform operator troubleshooting.

Step 2. Repair air conditioner units. (Refer to TM 5-4120-395-14&P for repair procedures on the 24,000 BTUH unit and to TM 5-4120-396-14&P for repair procedures on the 36,000 BTUH unit.)

Step 3. Remove and replace air conditioner units. (Refer to paragraph 4-14.)

4. AIR CONDITIONER ASSEMBLY MOUNTING BRACKET LOOSE OR BROKEN.

Step 1. Check for loose or missing hardware.

Tighten or replace hardware

Step 2. Check air conditioner mounting bracket for bent or broken metal strips.

Replace mounting bracket. (Refer to paragraph 4-15.)

5. AIR CONDITIONER DUCTING ASSEMBLY DOES NOT CONTROL AIR FLOW.

Step 1. Perform operator troubleshooting.

Step 2. Check operation of ceiling registers.

Replace ceiling registers. (Refer to paragraph 4-16a.)

4-10. UNIT TROUBLESHOOTING. - Continued

MALFUNCTION**TEST OR INSPECTION****CORRECTIVE ACTION**

Step 3. Check operation of end registers.

Replace end registers. (Refer to paragraph 4-16b.)

Step 4. Check access plate to solar bar push rod for damage or loose or missing hardware.

Replace access plate. (Refer to paragraph 4-16c.)

6. AIR CONDITIONER HOUSING ASSEMBLY DOES NOT OPERATE PROPERLY.

Step 1. Perform operator troubleshooting.

Step 2. Check operation of housing sidewall vent assembly.

Replace sidewall vent assembly. (Refer to paragraph 4-17a.)

Step 3. Check operation of housing sidewall vent assembly door latch.

Replace door latch. (Refer to paragraph 4-17b.)

Step 4. Check operation of heating element access plate in housing sidewall.

Replace access plate. (Refer to paragraph 4-17c.)

Step 5. Check operation of housing front vent assembly.

Replace front vent assembly. (Refer to paragraph 4-17d.)

Step 6. Check operation of housing assembly front wall vent assembly door latch.

Replace door latch. (Refer to paragraph 4-17e.)

4-10. UNIT TROUBLESHOOTING. - Continued

MALFUNCTION

TEST OR INSPECTION

CORRECTIVE ACTION

7. SINK ASSEMBLY FAILS TO OPERATE PROPERLY.

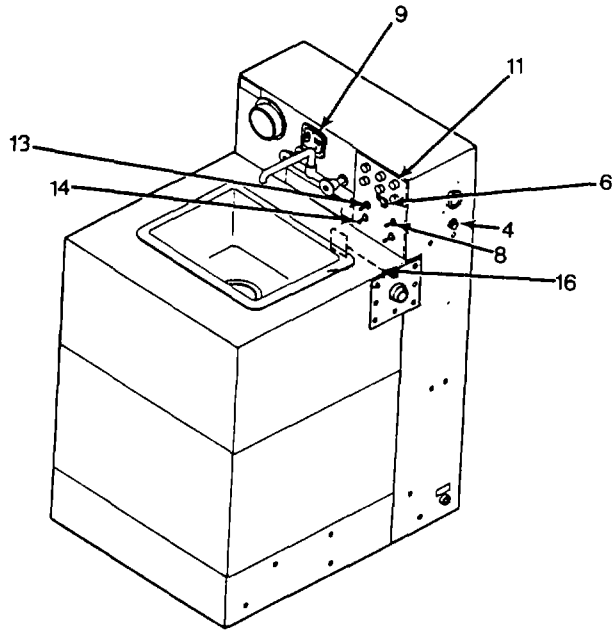
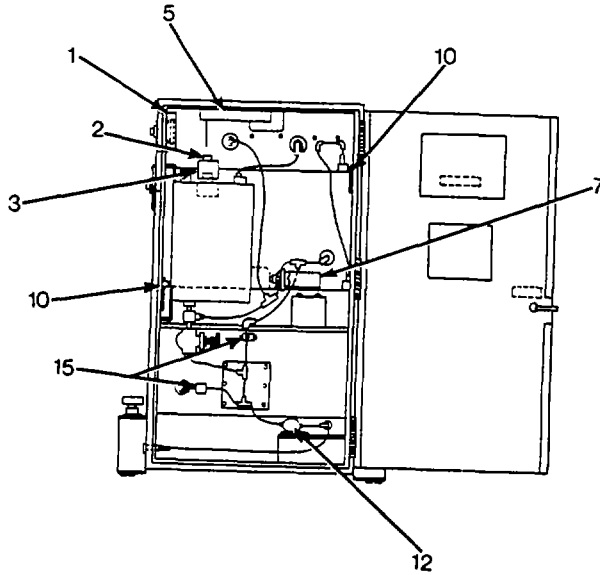

4-10. **UNIT TROUBLESHOOTING.** - Continued

MALFUNCTION**TEST OR INSPECTION****CORRECTIVE ACTION**

WARNING

Disconnect power to the sink assembly before opening rear door. DEATH on contact may result if power is not disconnected.

NOTE

These troubleshooting procedures for the sink assembly assume all indicator lamps are operational. Check for loose or broken wires before replacing any component part.

7a. All Systems Inoperable.

Step 1. Check circuit breaker for wall outlet.

Set circuit breaker to ON.

Step 2. Check Ground Fault Interrupter (GFI) receptacle (1) at rear of sink assembly.

Press reset button on GFI receptacle.

Step 3. Test for 110v AC at GFI receptacle.

Replace GFI receptacle. (Refer to paragraph 4-22n.)

Step 4. Check for broken or missing wires.

Replace wires. Refer to FO-1.

4-10. UNIT TROUBLESHOOTING. - Continued

MALFUNCTION**TEST OR INSPECTION****CORRECTIVE ACTION**7b. No Hot Water.**NOTE**

Wait 15 minutes between each test. Heater requires time to bring water up to desired temperature.

Step 1. Check Water Heater thermostat (2) setting.

Set thermostat knob to desired temperature. Do not set higher than 160°F.

Step 2. Check water heater. Unplug sink assembly from wall outlet, remove temperature indicator knob and cover on water heater (3), plug sink assembly into wall outlet, and test for 110v AC at Water Heater input wires.

If 110v AC is not present, replace switch S5. (Refer to paragraph 4-22e.)

If 110v AC is present, replace water heater. (Refer to paragraph 4-22h.)

7c. Fresh Water Pump Will Not Operate.

Step 1. Check fuse F1 (4) for continuity.

If open, replace fuse F1.

If 0 ohms, replace power supply (5). (Refer to paragraph 4-22f.)

Step 2. Check lamp DS4.

If not lit, replace switch S3 (6). (Refer to paragraph 4-22d.)

If lit, replace fresh water pump (7). (Refer to paragraph 4-22b.)

4-10. UNIT TROUBLESHOOTING. - Continued

MALFUNCTION**TEST OR INSPECTION****CORRECTIVE ACTION**

7d. Water Level Monitor Will Not Operate.

Step 1. Check tank for water.

Fill tank.

Step 2. Check Fresh Water/Gray Water selector switch/S4 (8).

Set switch S4 to desired tank.

Step 3. Check water level adjustment.

While holding test button in, rotate ADJUST TO FULL knob for correct reading.

Step 4. Check power to water level monitor by testing fuse F1 (4) for continuity.

If open, replace fuse F1. If 0 ohms, replace power supply (5). (Refer to paragraph 4-22f.)

Step 5. Check water level probes by setting Fresh Water/Gray Water selector switch S4 (8) to other tank and test water level.

If no reading, replace water level monitor (9). (Refer to paragraph 4-22i.) If good reading, replace probe (10) for tank with no reading. (Refer to paragraph 4-22j.)

7e. Drain Pump Will Not Operate.

Step 1. Check lamp DS3 (11) is lit.

If lit, replace drain pump (12). (Refer to paragraph 4-22c.)

Step 2. Check switch S2 (13) for continuity.

Replace switch S2. (Refer to paragraph 4-22d.)

If good, replace switch S1 (14). (Refer to paragraph 4-22d.)

4-10. UNIT TROUBLESHOOTING. - Continued

MALFUNCTION**TEST OR INSPECTION****CORRECTIVE ACTION**

7f. Drain Pump Operates For Both Tanks But Will Not Drain One of the Tanks.

Step 1. Determine which tank will not drain.

Replace solenoid valve (15) for corresponding tank. (Refer to paragraph 4-22k.)

7g. Drain Pump Will Only Operate and Drain One of the Tanks.

Step 1. Check switch S1 (14) operation.

Replace switch S1. (Refer to paragraph 4-22d.)

7h. Drain Pump Will Operate But Will Not Drain Either Tank.

Step 1. Check drain pump operation.

Repair drain pump by replacing impeller. (Refer to paragraph 4-22l.)

7i. Fresh Water Tank Will Not Fill.

Step 1. Check operation of float valve (16).

Adjust or replace float valve. (Refer to paragraph 4-22m.)

7j. Fresh Water Pours Out of Fresh Water Tank Inlet When Hose Removed.

Step 1. Check operation of float valve (16).

Replace defective float valve or float. (Refer to paragraph 4-22m.)

4-10. UNIT TROUBLESHOOTING. - Continued

MALFUNCTION**TEST OR INSPECTION****CORRECTIVE ACTION**

7k. Sink assembly is leaking.

Step 1. Turn off power to sink assembly.

Step 2. Find location of leak.

If leak occurs at a joint, tighten joint with pipe wrench. If leak occurs in a pipe or in a welded joint, replace sink assembly and return old sink assembly to depot for repair.

8. PASSAGEWAY TENT DOES NOT OPERATE PROPERLY.

Step 1. Refer to TM 10-5411-201-11 for repair procedures for the complexing kit.

9. ISO SHELTER DOES NOT OPERATE PROPERLY.

Step 1. Refer to TM 10-5411-200-14 for repair procedures for the ISO shelter.

10. PHASE MONITOR METER DOES NOT OPERATE PROPERLY.

Step 1. Remove fuse and test for continuity. Reading should be zero ohms.

Replace fuse.

Step 2. Check voltage meter.

Replace voltage meter. (Refer to paragraph 4-27a.)

Step 1. Check frequency meter.

Replace frequency meter. (Refer to paragraph 4-27e.)

4-10. UNIT TROUBLESHOOTING. - Continued

MALFUNCTION**TEST OR INSPECTION****CORRECTIVE ACTION**

Step 4. Reverse correct and incorrect phase lamp bulbs.

If correct phase light operates, replace defective lamp bulb.

WARNING

Main power cable must be disconnected from Press Section before performing further troubleshooting on phase monitor meter. Failure to do so may result in DEATH or serious injury.

Step 5. Request Module C operator set main circuit breaker in power distribution box to OFF position and disconnect main power cable from shelter. Remove screws holding phase monitor meter to wall. Remove phase monitor meter and check for broken or missing wires.

Replace wiring. Refer to FO-2.

Step 6. Test switches for continuity. Reading should be zero ohms.

Replace faulty switch. (Refer to paragraph 4-27d or f.)

If switches test good, replace circuit board. (Refer to paragraph 4-27g.)

11. PRINTING PRESS FAILS TO OPERATE PROPERLY.

Step 1. Refer to TM 5-3610-304-20/20P for repair procedures for the printing press.

12. EMERGENCY LIGHT DOES NOT OPERATE PROPERLY.

a. Emergency Light Does Not Light When Tested and Charge Light is Not Lit.

Step 1. Check that ON/OFF switch is set to ON.

Set ON/OFF switch to ON.

4-10. UNIT TROUBLESHOOTING. - Continued

MALFUNCTION**TEST OR INSPECTION****CORRECTIVE ACTION**

Step 2. Check that emergency light is plugged into wall outlet.

Plug in emergency light.

Step 3. Check that circuit breaker in power distribution panel is set to ON.

Set circuit breaker to ON.

WARNING

Before performing continuity checks or replacing electrical components, make sure that electrical power is completely disconnected from the circuit involved.

Step 4. Remove fuse on printed circuit board and check for continuity.

Replace fuse.

Step 5. Unplug emergency light, check for broken or unplugged wires, and test ON/OFF switch for continuity.

Replace wiring or switch (paragraph 4-30 b(2)).

Step 6. Test battery for an open.

Replace battery (paragraph 4-30 b(3)). If good, replace emergency light (paragraph 4-30 (a)).

b. Emergency Light Does Not Light When tested and Charge Light is Lit.

Step 1. Wait 20 minutes or until charge light starts to flicker and test.

Replace battery (paragraph 4-30 b(3)).

SECTION VI. UNIT MAINTENANCE PROCEDURES

4-11. **GENERAL.** This section contains unit maintenance procedures. Perform all preventive maintenance and operator maintenance before performing unit maintenance procedures. Numbers in parenthesis () after component or item discussed in paragraphs below refer to callouts in corresponding figures.

4-12. **ISLATROL CONTROL BOX ASSEMBLY.** Refer to figure 4-1 for location of components and hardware of islatrol control box assembly.

This task covers: a. Test b. Replace

INITIAL SETUP**Tools**

General Mechanics Automotive Tool Kit, Appendix B
Electrical Equipment Tool Kit, Appendix B
Multimeter, Appendix B

Materials

None

WARNING

High voltage exists in the electrical system of this equipment. DEATH on contact may result if personnel fail to observe safety precautions.

a. Test.

- (1) Place printing press circuit breaker on power distribution panel in OFF position.
- (2) Open control box door cover (1) to expose wiring (2).
- (3) Place printing press circuit breaker on power distribution panel in ON position.

4-12. ISLATROL CONTROL BOX ASSEMBLY. - Continued

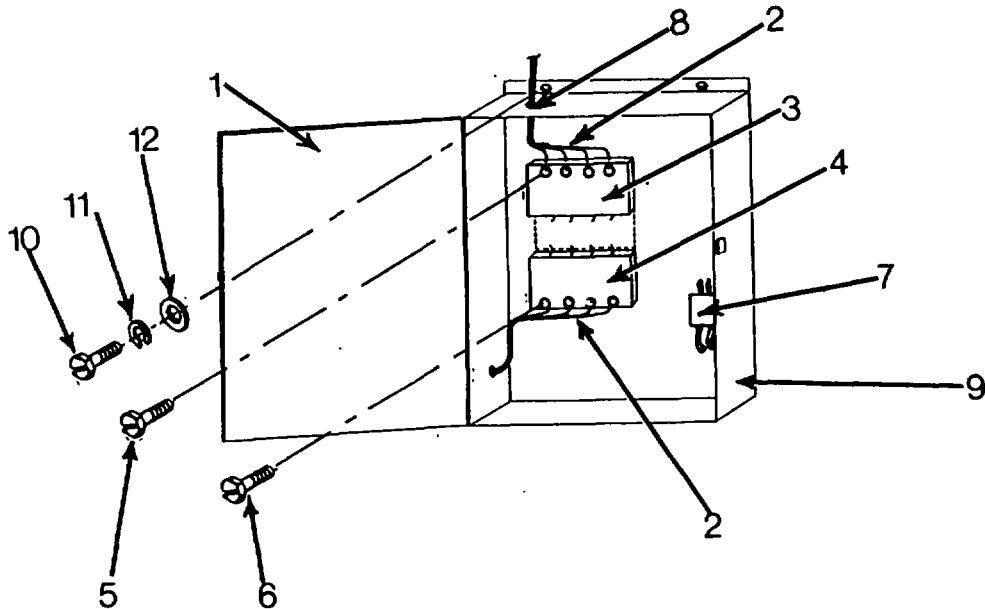

Figure 4-1. Islatrol Control Box Assembly

a. Test. - Continued

- (4) Using a multimeter, test each phase (A, B, C) for 208 ± 10 Vac on the line side terminal board (3).
- (5) Using a multimeter, test each phase (A, B, C) for 208 ± 10 Vac on the load side terminal board (4).
- (6) Place printing press circuit breaker on power distribution panel in OFF position.

4-12. ISLATROL CONTROL BOX ASSEMBLY. - Continued

b. Replace.

- (1) Remove screws (5) securing wires (2) to line terminal board (3). Tag wires for later reference.
- (2) Remove screws (6) securing wires (2) to load terminal board (4). Tag wires for later reference.
- (3) Loosen grounding lugs (7) and disconnect ground wires.
- (4) Loosen nuts (8) on load and line cable conduits and pull cables out of islatrol control box (9).
- (5) Remove screws (10), lockwashers (11), flat washers (12), and islatrol control box.
- (6) Install replacement islatrol control box (9) and secure with flat washers (12), lockwashers (11), and screws (10).
- (7) Install load and line cable conduits and tighten nut (8).
- (8) Connect ground wires to grounding lug (7).
- (9) Install wires (2) on load terminal board (4) and secure with screws (6). Remove wire tags.
- (10) Install wires (2) on line terminal board (3) and secure with screws (5). Remove wire tags.
- (11) Close control box door cover (1).
- (12) Place printing press circuit breaker on power distribution panel in ON position.
- (13) Operate printing press.

4-13. **CARGO DOOR VENT ASSEMBLY.** Refer to figure 4-2 for location of components and hardware of cargo door vent assemblies.

This task covers: a. Test b. Replace

INITIAL SETUP

Tools

- General Mechanics Automotive Tool Kit, Appendix B
- Multimeter, Appendix B
- Eye Goggles
- Riveter, Blind, Appendix B

Materials

- RTV Sealing Compound

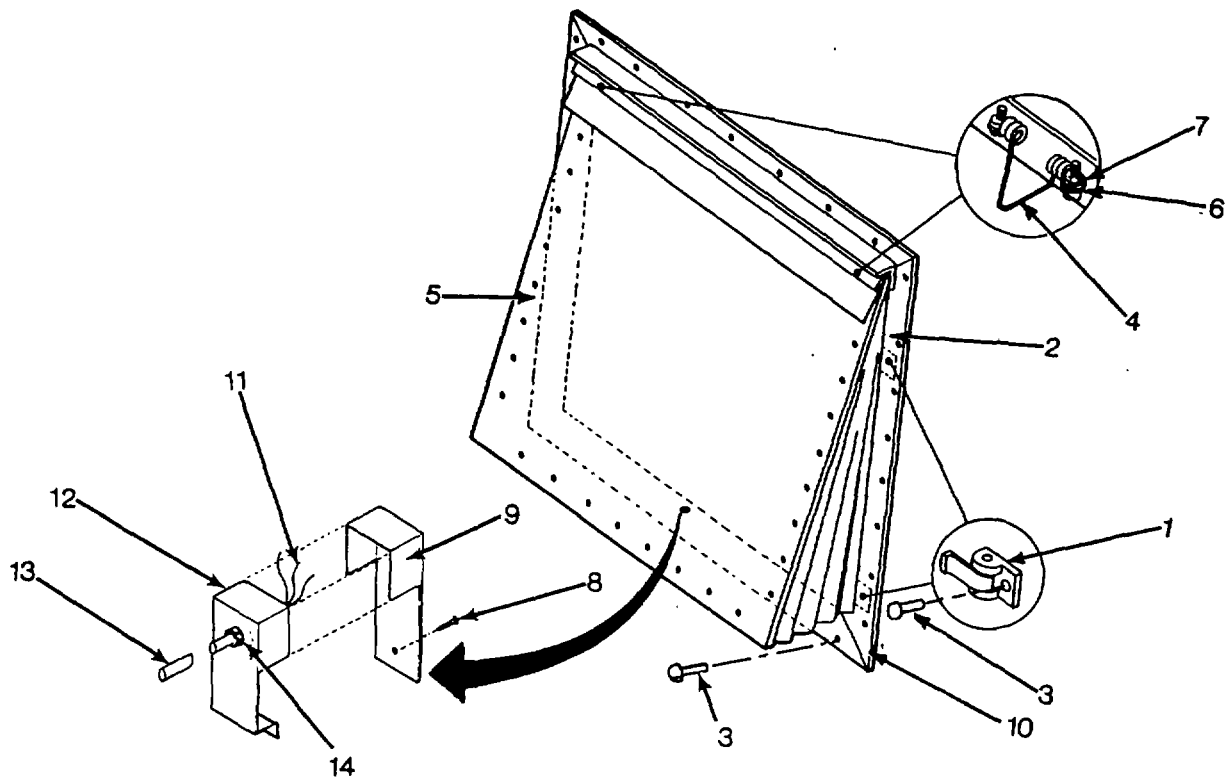

Figure 4-2. Cargo Door Vent Assemblies

4-13. CARGO DOOR VENT ASSEMBLY. - Continued

WARNING

Use eye goggles when drilling metal parts. Failure to do so may result in serious eye injury from flying metal fragments.

a. Repair.

- (1) Repair by replacing door latch (1) on cargo door vent assembly (2).
 - (a) Using an electric drill, drill out blind rivets (3) on wing latch (1).
 - (b) Install replacement latch (1) using riveter and blind rivets (3).
- (2) Repair by replacing torsion spring (4) on cargo door vent assembly (2).
 - (a) Open vent door (5).
 - (b) Remove screws (6) and washers (7).
 - (c) Remove spring (4).
 - (d) Install replacement spring (4) and secure with washers (7) and screws (6).
- (3) Repair by replacing push-button switch (12) on cargo door vent assembly (2).
 - (a) Place main circuit breaker on power distribution panel in OFF position.
 - (b) Open vent door (5).
 - (c) Remove screw (8) securing switch cover (9) to vent assembly housing (10) and remove switch cover (9).
 - (d) Disconnect electrical wiring (11) from switch (12). (Tag wires for reinstallation on replacement switch.)
 - (e) Pull knob (13) off switch (12), remove nut (14), and remove switch (12).
 - (f) Connect electrical wiring (1) to replacement switch (12) and remove tags.

NOTE

Air conditioner will not operate with vent door closed when push-button switch is operational.

- (g) Secure replacement switch (12) to vent assembly housing using nut (14).
- (h) Push on knob (13).
- (i) Position switch cover (9) and secure with screw (8).
- (j) Close and secure vent assembly door (5).

4-13. **CARGO DOOR VENT ASSEMBLY.** - Continued

- (k) Place main circuit breaker on power distribution panel in ON position.
- (l) Operate air conditioner unit.
- (m) Open vent door.
- (n) Operate air conditioner unit. Air conditioner units should operate properly when all vent doors are opened.

(4) Replace Cargo Door Vent Assembly.

- (a) Place main circuit breaker on power distribution panel in OFF position.
- (b) Remove screw (8) and switch cover (9) and disconnect wiring (11) from push button switch.
- (c) Using an electric drill, drill out all rivets (3) on vent assembly frame.
- (d) Remove cargo door vent assembly (2).
- (e) Remove RTV sealing compound around opening for cargo door vent assembly frame.
- (f) Lay a bead of RTV sealing compound along edge of vent door opening.
- (g) Position replacement cargo door vent assembly over holes in cargo door.
- (h) Using riveter, install blind rivets (3) in vent assembly housing (10).
- (i) Reconnect wiring (11) to push button switch and attach switch cover (9) with screw (8).
- (j) Place main circuit breaker on power distribution panel in ON position.

4-14. **AIR CONDITIONER ASSEMBLY.** (24,000 BTUH and 36,000 BTUH). Refer to figure 4-3 for location of components and hardware on the air conditioner assembly.

This task covers: Replace

INITIAL SETUP

Tools

- Electrical Equipment Tool Kit, Appendix B
- General Mechanics Automotive Tool Kit, Appendix B
- Fork Lift

Materials

None

NOTE

**The following procedure is for the 36,000 BTUH air conditioner assembly.
The procedure for the 24,000 BTUH air conditioner assembly is similar.**

4-14. **AIR CONDITIONER ASSEMBLY.**

- (1) Place air conditioner circuit breaker on power distribution panel in OFF position.

WARNING

Never connect or disconnect any power cables when electrical power is energized to the cables. Failure to do so will result in damage to equipment and/or serious injury or DEATH to personnel.

- (2) Open cargo doors (1) and disconnect door holder bracket (2).
- (3) Remove screws (3).
- (4) Loosen quick release (4) and remove access cover (5).
- (5) Remove filter (6).
- (6) Remove screws (7) and electrical cover (8).
- (7) Tag and disconnect thermostat wires (9).
- (8) Tag and disconnect grounding wires (10).
- (9) Tag and disconnect main power wires (11).
- (10) Remove tie straps (12).
- (11) Pull electrical cables out and away from air conditioner assembly.
- (12) Remove screws (13) and intermediate duct (14).
- (13) Remove nuts (15), lockwashers (16), flat washers (17), bolts (18), and angle brackets (19).
- (14) Remove tie straps (20) and disconnect tee connector (21) from drain hose (22).
- (15) Working inside shelter, remove screws (1, Figure 4-4), front vent door (2), and shim (3).
- (16) Remove filter (4).
- (17) Remove filter support (5).
- (18) Remove six nuts (6), lockwashers (7), flat washers (8) and bolts (9).

4-14. AIR CONDITIONER ASSEMBLY. - Continued

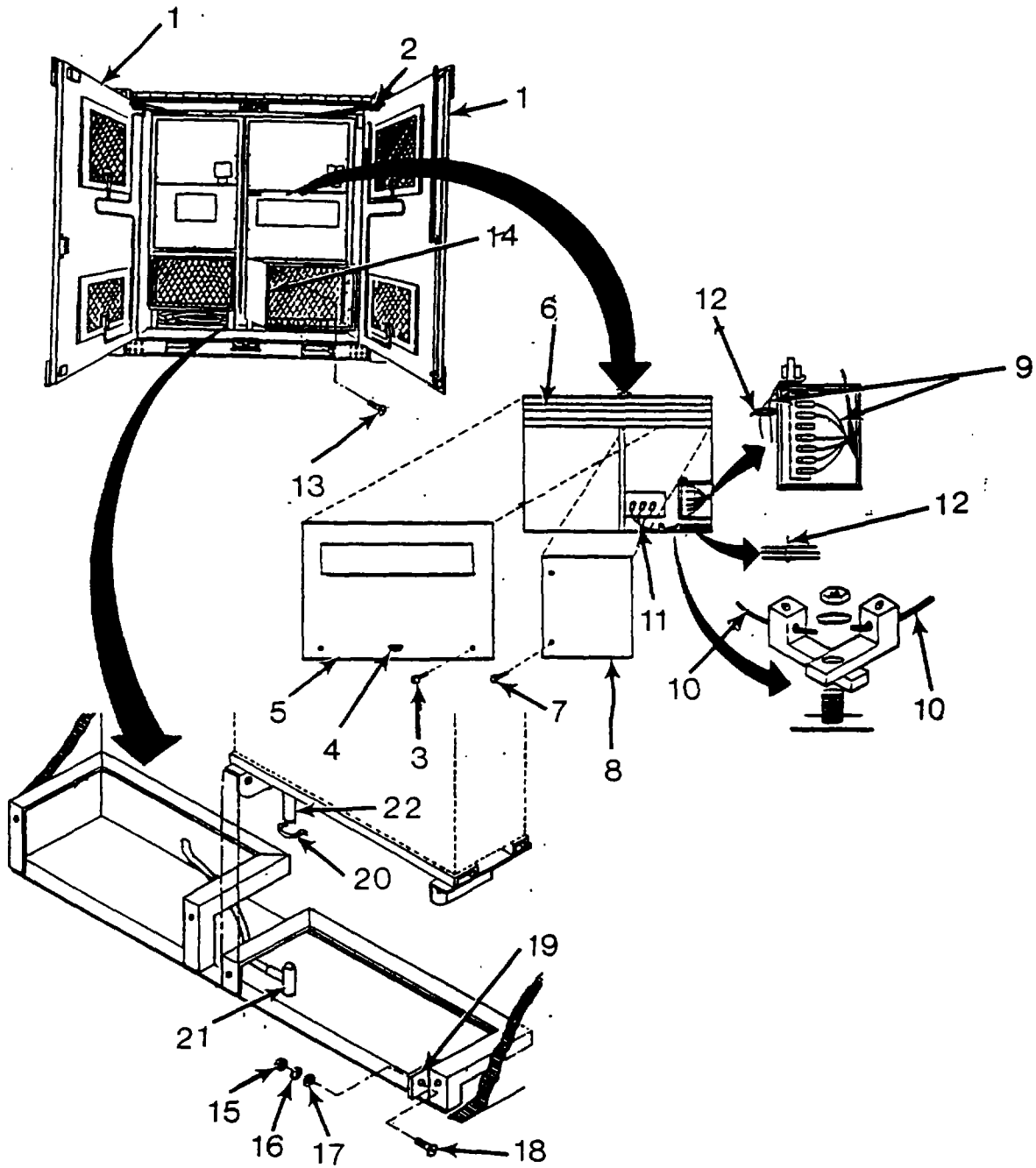

Figure 4-3. Air Conditioner Assembly (Outside)

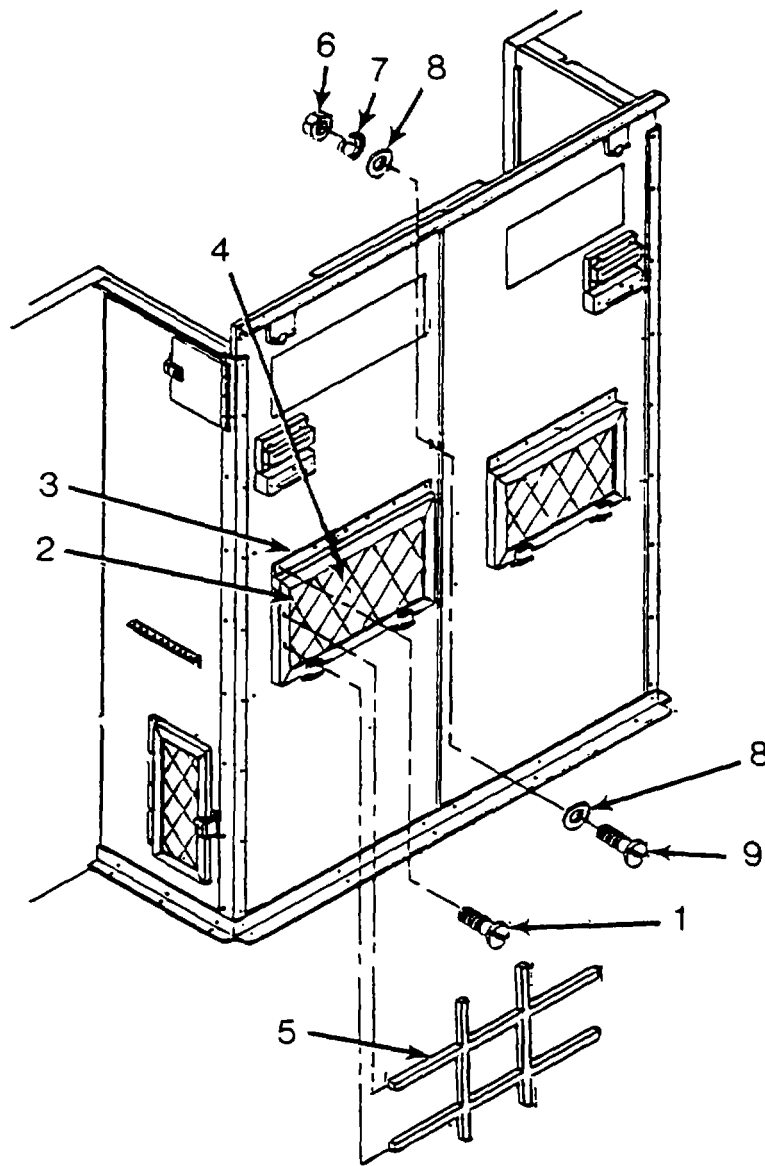

Figure 4-4. Air Conditioner Assembly (Inside)

4-14. AIR CONDITIONER ASSEMBLY. - Continued

CAUTION

Raise air conditioner assembly only enough to clear mounting bracket. Raising air conditioner assembly too much could result in damage to equipment.

NOTE

This task requires two persons. One person drives fork lift and the second person guides the fork lift tines to correct position under air conditioner mounting bracket. The second person will also balance the air conditioner on the fork lift while it is being removed from the shelter and feed the electrical cables through the unit.

(19) Slide air conditioner forward until rear of air conditioner mounting bracket (1, Figure 4-5) clears lower mounting bracket assembly (2).

(20) Carefully guide fork lift tines (3) under air conditioner mounting bracket (1) and move fork lift forward one foot to rear of mounting bracket (1).

(21) Lift air conditioner from lower mounting bracket assembly (2) and guide fork lift operator back from shelter.

(22) Lower air conditioner to ground.

4-14. AIR CONDITIONER ASSEMBLY. - Continued

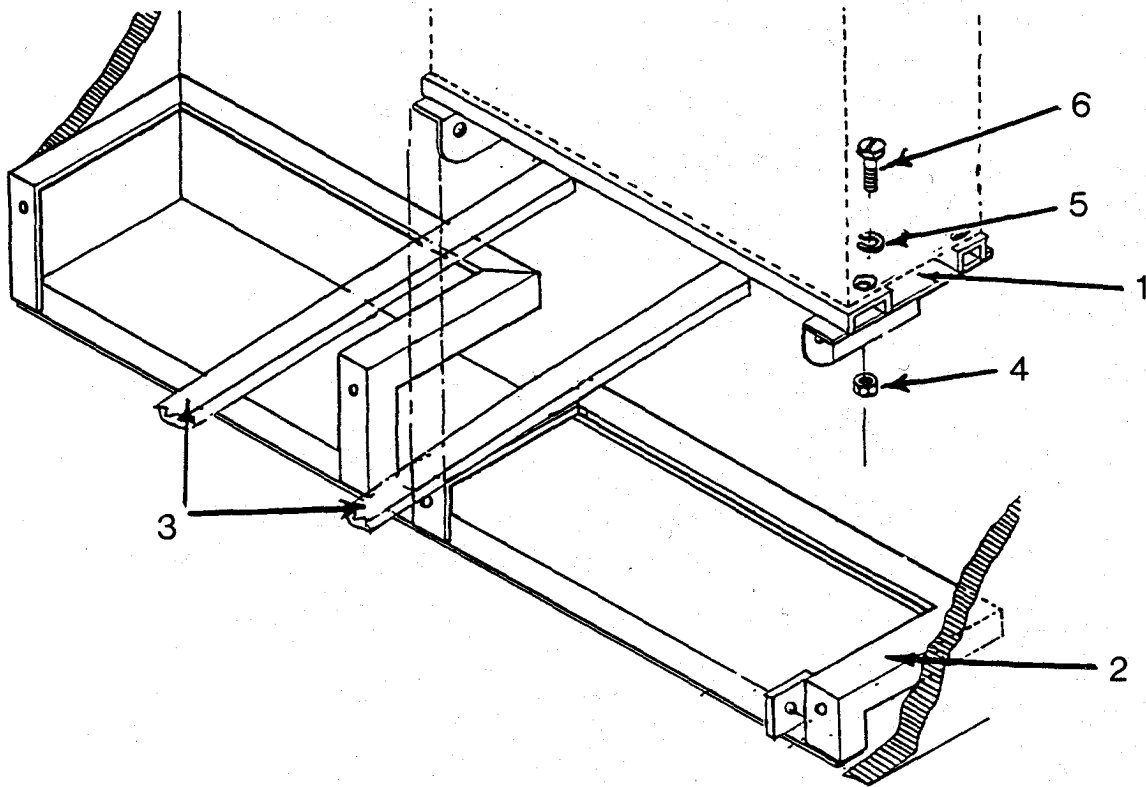

Figure 4-5. Lifting Air Conditioner With Fork Lift

WARNING

The 24,000 BTUH air conditioner weighs 330 pounds (149.5 kilograms) and the 36,000 BTUH air conditioner weighs 405 pounds (183.87 kilograms). Extreme care must be taken when lowering the air conditioner face down on the ground to prevent serious injury to personnel or damage to air conditioners.

4-14. **AIR CONDITIONER ASSEMBLY.** - Continued

- (23) Carefully lay the unit face down on the ground.
- (24) Remove four nuts (4), washers (5), bolts (6), and air conditioner mounting bracket (1).
- (25) Lay replacement air conditioner face down on the ground.
- (26) Attach air conditioner mounting bracket (1) to bottom of air conditioner using bolts (6), washers (5), and nuts (4).

NOTE

Make sure air conditioner is placed on fork lift so that front of air conditioner will be facing cargo door entrance for installation.

- (27) Move fork lift into position and raise air conditioner to upright position on fork lift tines. Tie a stiff wire to the electrical cables to feed them through the electrical passage.
- (28) Lift air conditioner and move to installation site at shelter cargo door entrance.
- (29) Carefully guide fork lift forward and lower air conditioner on to lower mounting bracket assembly.
- (30) Guide fork lift away from shelter.
- (31) Align holes in air conditioner mounting bracket (1) with holes in lower mounting bracket assembly (2) and secure with angle brackets (19, Figure 4-3), bolts (18), flat washers (17), lockwashers (16), and nuts (15).
- (32) Connect tee connector (21) to drain hose (22) and secure with tie strap (20).
- (33) Position intermediate duct (14) and secure with screws (13).
- (34) Reconnect the main power wires (11), grounding wires (10).
- (35) Cut and strip blue wire coming from transformer on replacement air conditioner. Reconnect thermostat wires (9). Remove tags and install tie straps (12).
- (36) Position electrical cover (8) and secure with screws (7).
- (37) Position access cover (5) and secure quick release (4).

4-14. **AIR CONDITIONER ASSEMBLY.** - Continued

- (38) Install screws (3).

CAUTION

While drilling holes, ensure drain hose behind right side of air conditioning housing front panel is not damaged.

NOTE

Check alignment of front vent door with opening in air conditioner assembly.

- (39) Using an electric drill and the six holes in the air conditioning housing front panel as a template, drill six 1/4" holes through air conditioner housing.
- (40) Install six bolts (9, Figure 4-4), flat washers (8), lockwashers (7), and nuts (6).
- (41) Position shim (3) and front vent door (2) and secure with screws (1).
- (42) Install filter support (5).
- (43) Install filter (4).
- (44) Reconnect door holder bracket (2, Figure 4-3) and close cargo doors (1).
- (45) Open cargo door vent assembly doors.
- (46) Place air conditioner circuit breaker on power distribution panel in ON position.
- (47) Operate air conditioner.

4-15. **AIR CONDITIONER MOUNTING BRACKET ASSEMBLY (24,000 BTUH AND 36,000 BTUH)**. Refer to figure 4-6 for location of components and hardware on air conditioner mounting bracket.

This task covers: Replace

INITIAL SETUP

Tools

General Mechanics Automotive Tool Kit, Appendix B

Materials

RTV Sealing Compound

- a. Remove air conditioner assemblies from shelter. (Refer to paragraph 4-14.)
- b. Remove bolts (1), lockwashers (2), flat washers (3), and mounting bracket assembly (4).
- c. Remove screws (5) and drip pan (6) if necessary.
- d. Remove RTV sealing compound from mating materials.
- e. Position drip pan (6) and secure with screws (5).
- f. Seal drip pan (6) with RTV sealing compound.
- g. Position mounting bracket assembly (4) and secure flat washers (3), lockwashers (2) and bolts (1).
- h. Install air conditioner assemblies in shelter. (Refer to paragraph 4-14.)

4-15. AIR CONDITIONER MOUNTING BRACKET ASSEMBLY (24,000 BTUH AND 36,000 BTUH). - Continued

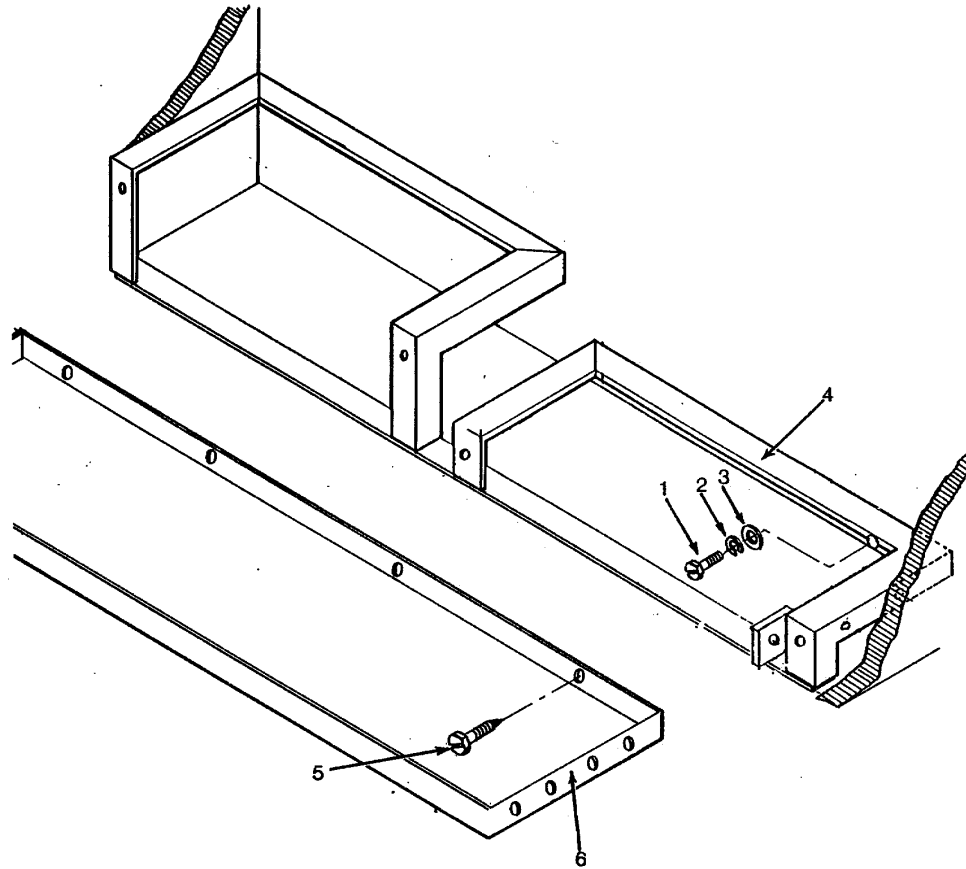

Figure 4-6. Air Conditioner Mounting Bracket Assembly
(24,000 BTUH and 36,000 BTUH)

4-16. **AIR CONDITIONER DUCTING ASSEMBLY.**

This task covers: Repair

INITIAL SETUP

Tools

General Mechanics Automotive Tool Kit

Materials

None

a. Repair by replacing ceiling vent 4-way register (1). (Figure 4-7.)

(1) Remove mounting screws (2) from register housing and remove register (1) from AC ducting assembly.

(2) Align replacement register (1) over holes in AC ducting assembly and secure in place with mounting screws (2).

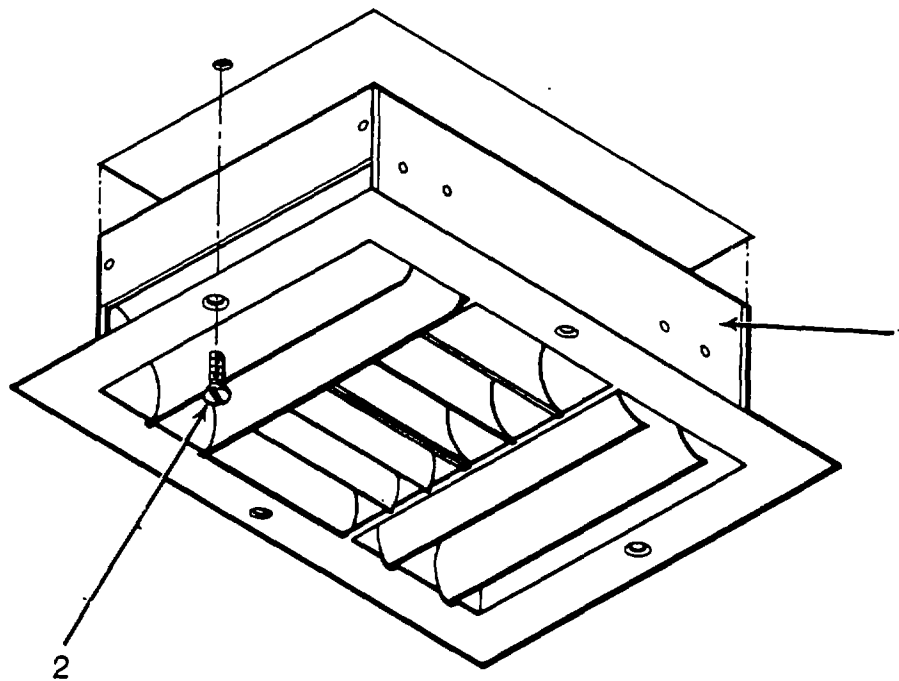

Figure 4-7. Air Conditioner Ducting Assembly 4-Way Register

4-16. AIR CONDITIONER DUCTING ASSEMBLY. - Continued

b. Repair by replacing end register (1). (See figure 4-8.)

- (1) Remove mounting screws (2) and remove end register (1) from AC ducting assembly (3).
- (2) Align replacement end register (1) over holes in AC ducting assembly (3) and secure in place with mounting screws (2).

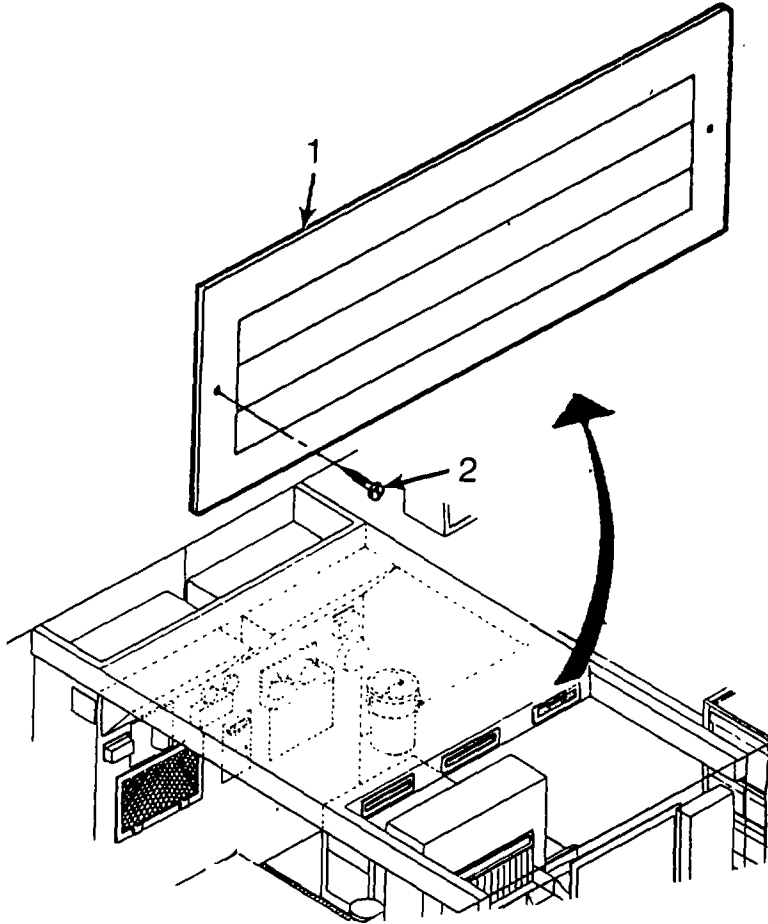

Figure 4-8. End Registers

4-16. AIR CONDITIONER DUCTING ASSEMBLY. - Continued

c. Repair by replacing access plate (1) to solar bar push rod. (See figure 4-9.)

- (1) Remove mounting screws (2) from access plate and remove access plate (1) from AC ducting assembly (3).
- (2) Align replacement access plate (1) over holes in AC ducting assembly (3) and secure in place with mounting screws (2).

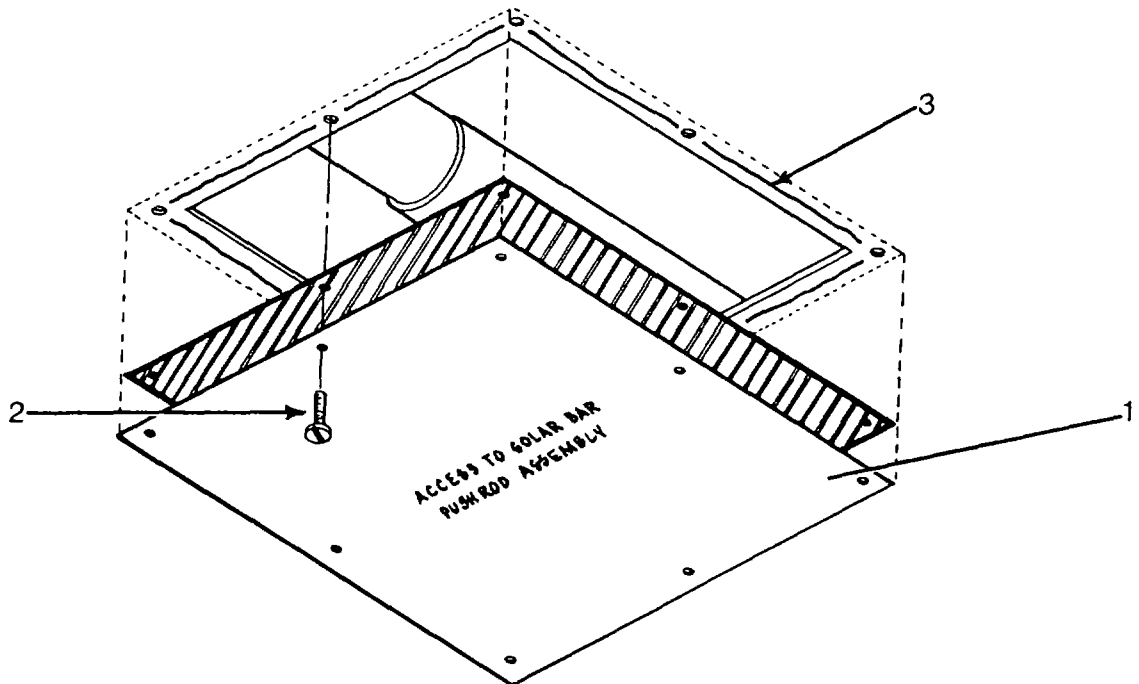

Figure 4-9. Solar Bar Push Rod Access Plate

4-17. AIR CONDITIONER HOUSING ASSEMBLY. Refer to figure 4-10 for location of air conditioning assembly components (sidewall vent assembly (1), heating element access plate (2), and front wall vent assembly (3)).

This task covers: Repair

INITIAL SETUP

Tools

General Mechanics Automotive Tool Kit, Appendix B

Materials

None

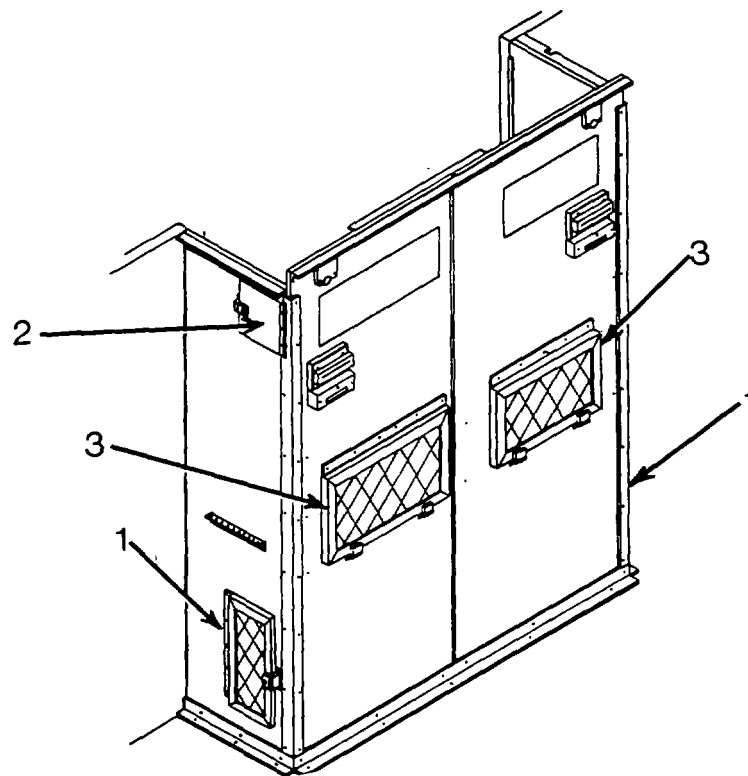

Figure 4-10. Air Conditioner Housing Assembly

4-17. AIR CONDITIONER HOUSING ASSEMBLY. - Continued

a. Repair by replacing housing sidewall vent assembly. (See figure 4-11.)

(1) Remove five self-tapping screws (1) along top of hinge (2) and remove vent assembly (3).

(2) Align replacement vent assembly hinge (2) along hinge line and secure in place with five self-tapping screws (1).

b. Repair by replacing sidewall vent assembly door latch (4). (See figure 4-11.)

(1) Using an electric drill, drill out rivets (5) in latch (4) and remove latch (4).

(2) Install replacement latch (4) using blind riveter and pop rivets.

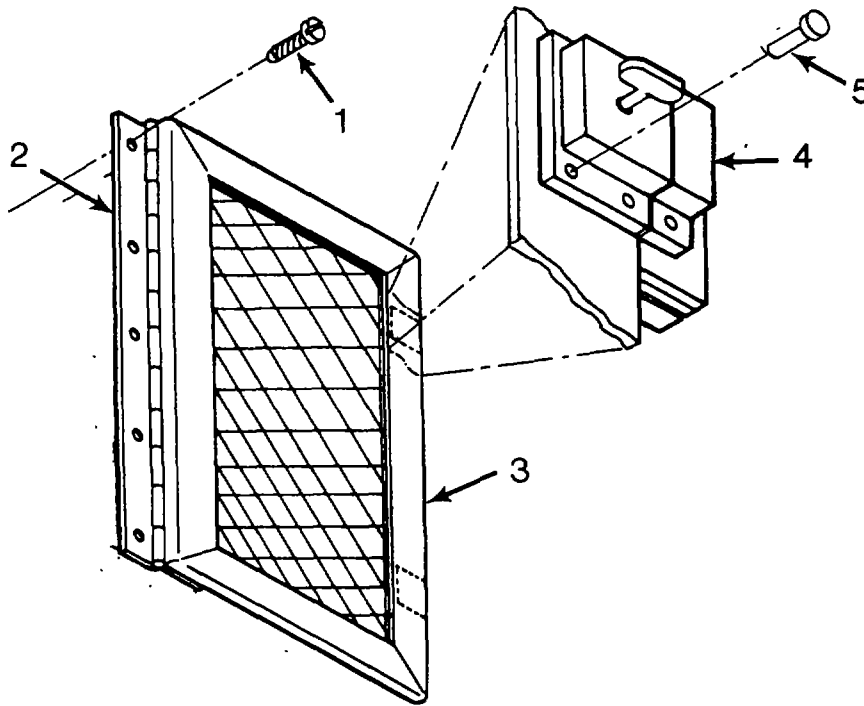

Figure 4-11. Sidewall Vent Assembly

4-17. AIR CONDITIONER HOUSING ASSEMBLY. - Continued

- c. Repair by replacing heating element access plate (2). (See figure 4-12.)

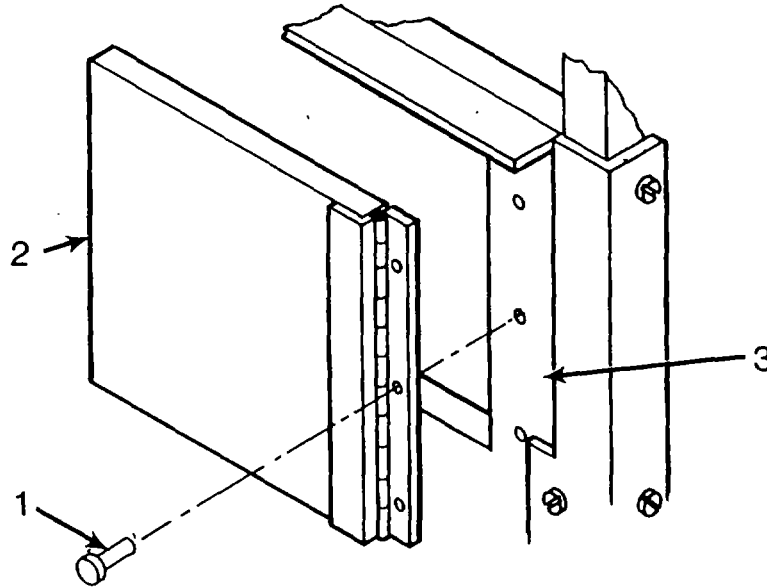

Figure 4-12. Heating Element Access Plate

(1) Using an electric drill, drill out rivets (1) securing access plate (2) to housing sidewall (3) and remove access plate (2).

(2) Align holes in replacement access plate (2) with holes in housing sidewall (3) and secure in place with rivets (1) using hand blind riveter.

NOTE

Replacement procedures for the front wall vent assemblies and vent assembly latches in the AC housing of both the 24,000 BTUH air conditioner and the 36,000 BTUH air conditioner are the same.

4-17. AIR CONDITIONER HOUSING ASSEMBLY. - Continued

d. Repair by replacing front wall vent assembly. (Figure 4-13.)

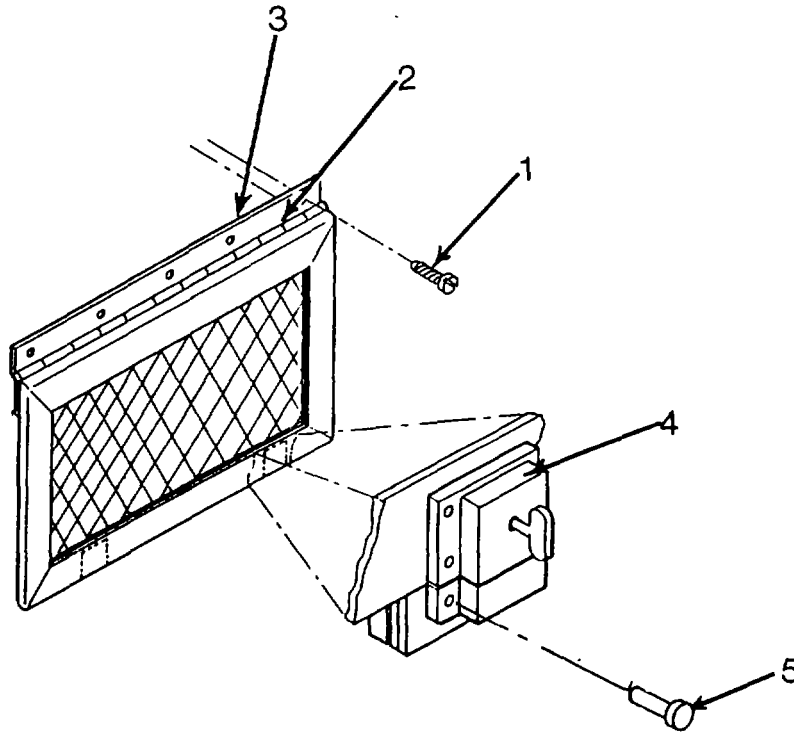

Figure 4-13. Front Wall Vent Assembly

(1) Remove self-tapping screws (1) along top of vent assembly hinge (2) and remove front wall vent assembly.

(2) Align replacement vent assembly hinge (2) along hinge line and secure in place with five self-tapping screws (1).

e. Repair by replacing front wall vent assembly door latch. (Figure 4-13.)

(1) Using an electric drill, drill out rivets (5) in latch and remove latch (4).

(2) Install replacement latch (4) using blind riveter and pop rivets.

4-18. INK CART AND TOOL CADDY. Refer to figure 4-14 for location of components and hardware of the ink cart and tool caddy.

This task covers: Repair

INITIAL SETUP

Tools

General Mechanics Automotive Tool Kit

Materials

None

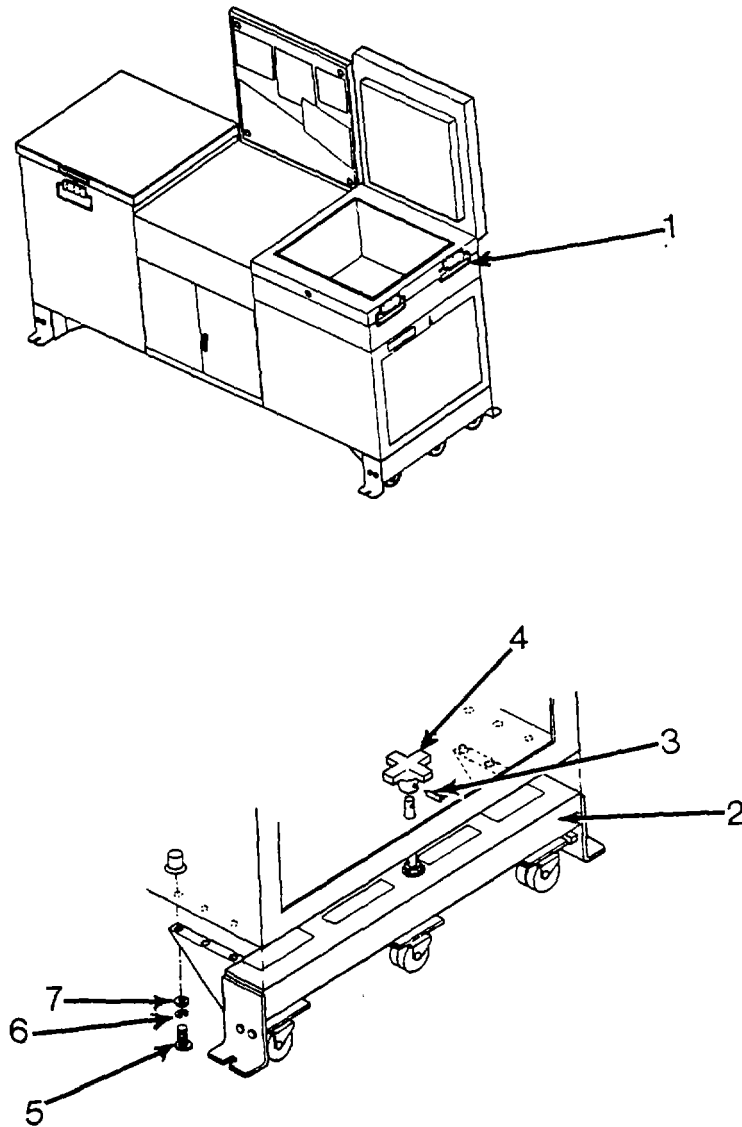

Figure 4-14. Ink Cart and Tool Caddy

4-18. INK CART AND TOOL CADDY. - Continued

- a. Replace loose or missing rivets on cart handles (1).
- b. Tighten or replace loose or missing bolts, nuts and washers on ink cart and tool caddy transporter assembly (2).
- c. Repair by replacing transport assembly.
 - (1) Place wood blocks under ink cart and tool caddy.
 - (2) Raise transporter wheels until clear of the floor.
 - (3) Remove spring pin (3) and control knob (4).
 - (4) Remove bolts (5) lockwashers (6), and flat washers (7) securing transporter assembly to cart and remove transporter assembly (2).
 - (5) Align holes in replacement transporter assembly with holes in cart and secure in place with bolts (5), lockwashers (6), and flat washers (7).
 - (6) Replace spring pin (3) and control knob (4).

4-19. GTO CABINET ASSEMBLY. Refer to figure 4-15 for location of components and hardware of the GTO cabinet assembly.

This task covers: Repair

INITIAL SETUP

Tools

General Mechanics Automotive Tool Kit, Appendix B

Materials

None

4-19. GTO CABINET ASSEMBLY. - Continued

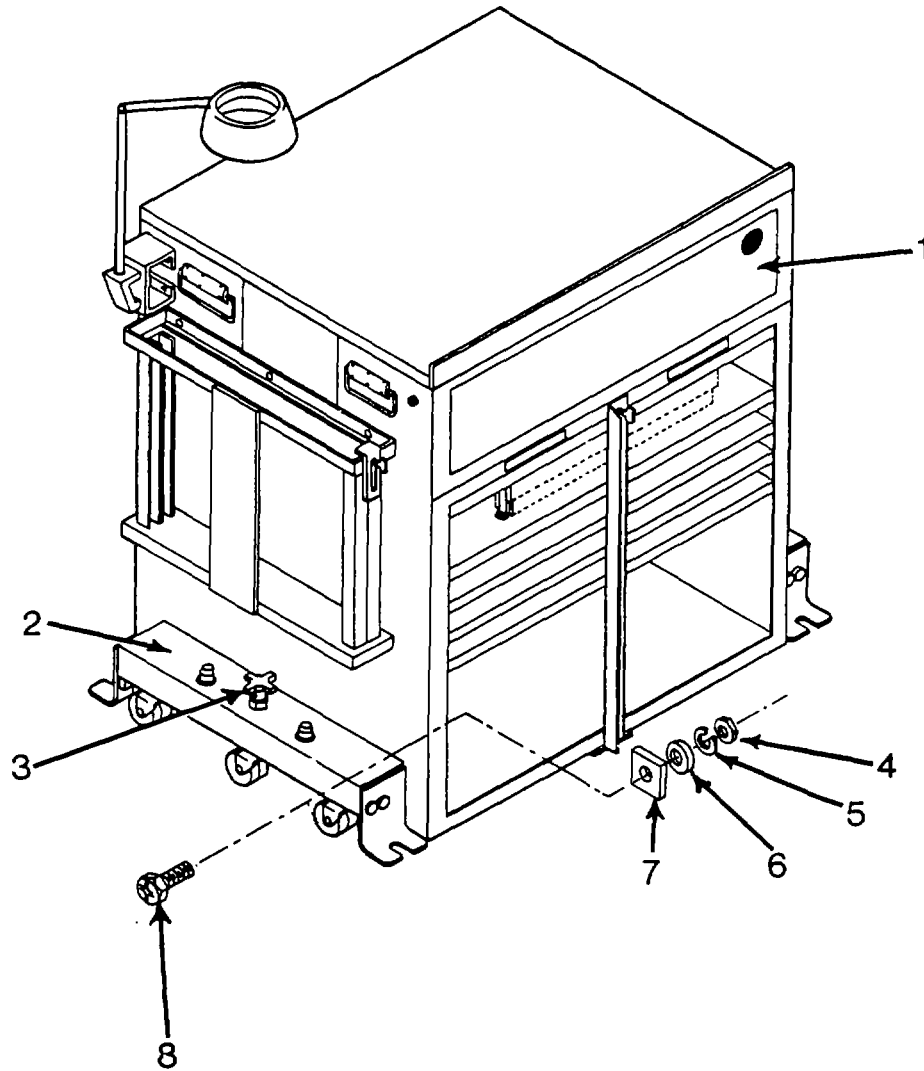

Figure 4-15. GTO Cabinet Assembly

4-19. GTO CABINET ASSEMBLY. - Continued

- a. Tighten or replace loose or missing bolts, nuts or washers on GTO cabinet assembly (1).
- b. Tighten or replace loose or missing bolts, nuts or washers on GTO cabinet assembly transporter assembly (2)
- c. Repair by replacing transporter assembly.

(1) Using control knob (3) on transporter assembly, lower GTO cabinet assembly to floor of shelter.

(2) Unload and remove bottom drawer.

(3) Remove nuts (4), lockwashers (5), flat washers (6), plate stiffeners (7), and bolts (8) securing transporter assembly to GTO assembly and remove transporter assembly.

(4) Align holes in replacement transporter assembly with holes in GTO cabinet assembly and secure in place with nuts (4), lockwashers (5), flat washers (6), plate stiffeners (7), and bolts (8).

4-20. WALL MOUNTED STORAGE CABINET. Refer to figure 4-16 for location of components and hardware of the storage cabinet.

This task covers: Replace

INITIAL SETUP

Tools

General Mechanics Automotive Tool Kit, Appendix B

Materials

None

4-20. WALL MOUNTED STORAGE CABINET. - Continued

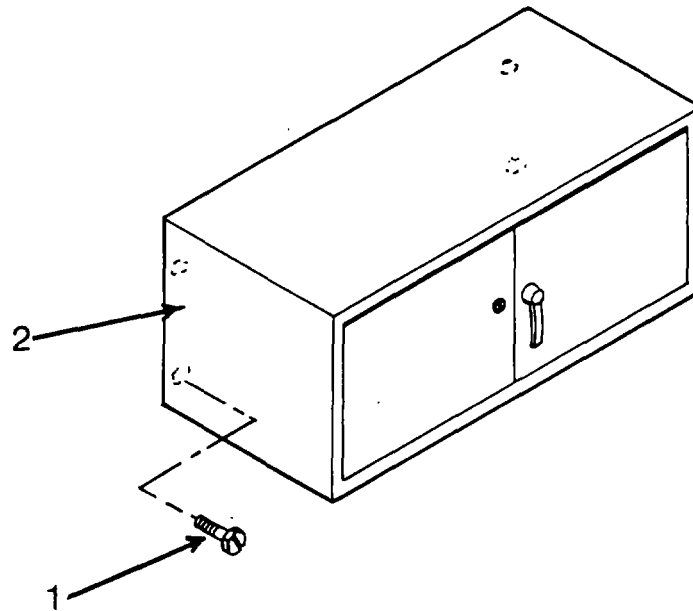

Figure 4-16. Wall Mounted Storage Cabinet

- a. Replace storage cabinet by removing mounting bolts (1) remove storage cabinet (2).
- b. Align storage cabinet (2) with holes in wall and secure with mounting bolts (1).

4-21. FOLDING TABLE. Refer to figure 4-17 for location of components and hardware of the folding table (1).

This task covers: Repair

INITIAL SETUP

Tools

General Mechanics Automotive Tool Kit, Appendix B

Materials

None

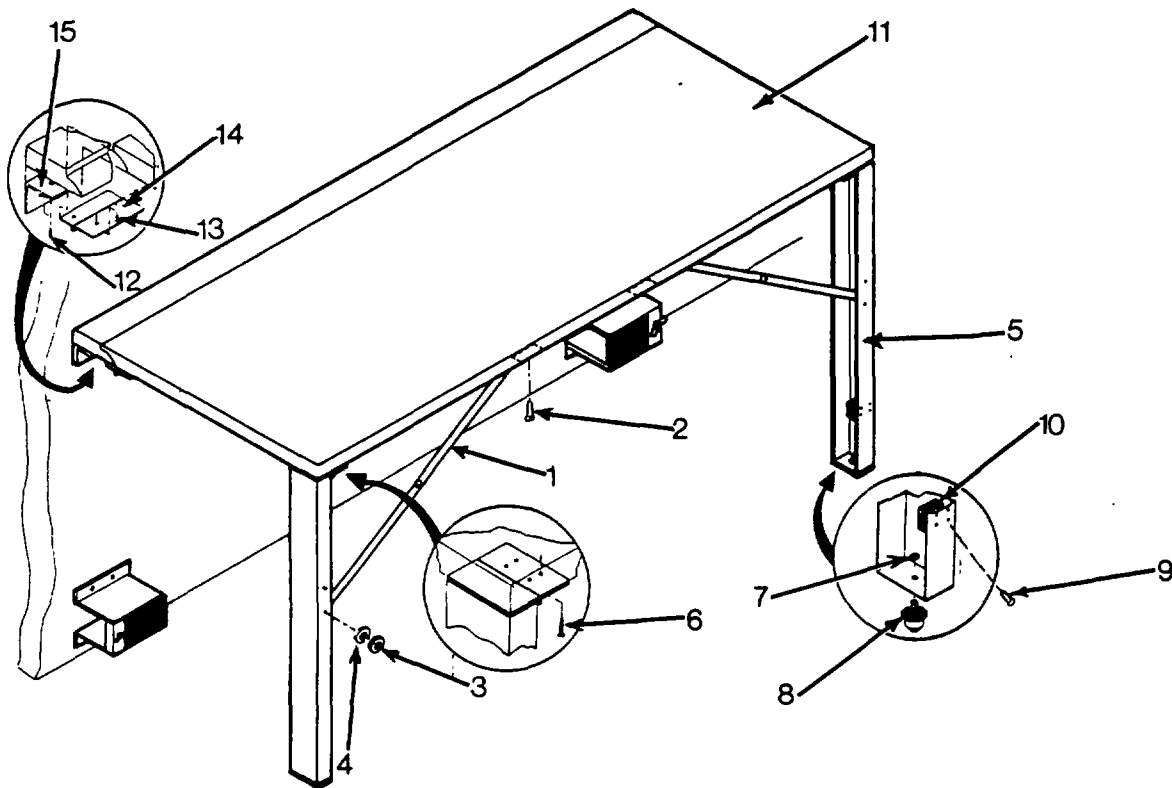

Figure 4-17. Folding Table

4-21. FOLDING TABLE. - Continued

- a. Repair by replacing locking brace (1).
 - (1) Remove screws (2), nuts (3), flat washers (4), and locking brace (1).
 - (2) Position replacement locking brace (1) and secure with screws (2), nuts (3) and flat washers (4).

- b. Repair by replacing leg (5).
 - (1) Remove locking brace (1). (See a. above.)
 - (2) Remove screws (6) and leg (5).
 - (3) Remove nut (7) and remove foot (8).
 - (4) Drill rivets (9) using electric drill and remove magnetic latch (10).
 - (5) Install magnetic latch (10) on replacement leg (5) using blind riveter and rivets (9).
 - (6) Install foot (8) and nut (7) on replacement leg (5).
 - (7) Position replacement leg (5) and secure with screws (6).

- c. Repair by replacing table top (11).
 - (1) Remove screws (12) and remove folding table.
 - (2) Remove legs (5). (See b. above.)

4-21. FOLDING TABLES.- Continued

- (3) Remove screws (13) and hinge (14).
- (4) Position two parts of replacement table top (11) on flat surface and secure hinge (14) with screws (13).
- (5) Install legs (5). (See b. above.)
- (6) Position folding table on wall bracket (15) and secure with screws (12).

4-22. SINK ASSEMBLY.

This task covers: a. Replace b. Repair

INITIAL SETUP

Tools

General Mechanics Automotive Tool Kit, Appendix B
Pipe Wrench, Appendix B

Materials

Tape, thread seal, MIL-T-27730A
RTV Sealing Compound
Petroleum Jelly

Tools

General Mechanics Automotive Tool Kit, Appendix B

- a. Replace. (Figure 4-18.)

- (1) Place sink assembly circuit breaker in Power Distribution Panel to OFF position.
- (2) Remove sink assembly power connector (1) from wall socket.
- (3) Disconnect water supply line (2) and drain line (3).
- (4) Lower sink transport wheels using transporter knobs (4) and remove sink assembly from shelter.
- (5) Place new sink assembly in shelter.

NOTE

If new sink assembly does not have transporter assemblies attached, refer to paragraph 4-22.o.

4-22. SINK ASSEMBLY. - Continued

- (6) Connect water supply line (2) and drain line (3).
- (7) Connect sink assembly power connector (1).
- (8) Place sink assembly circuit breaker in ON position.
- (9) Operate sink assembly.

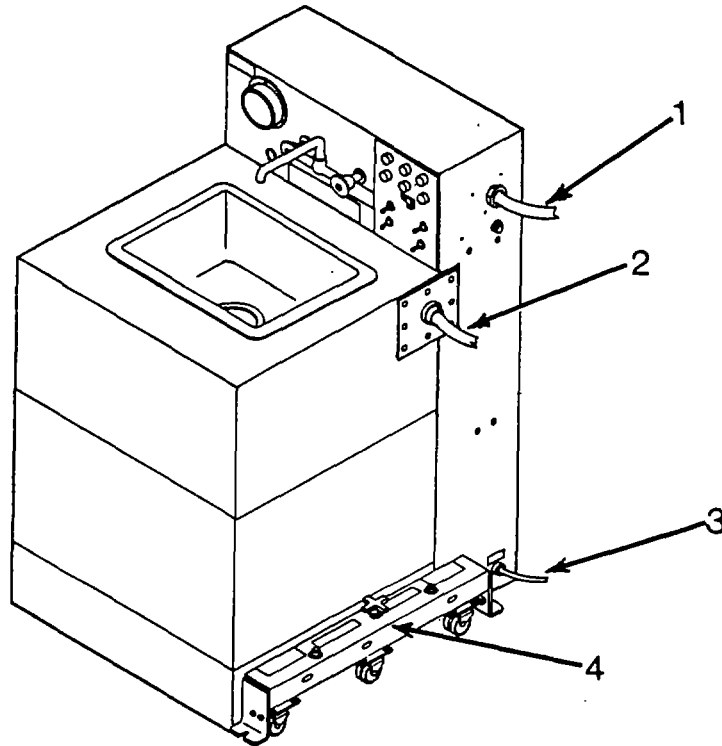

Figure 4-18. Sink Assembly

4-22. SINK ASSEMBLY. - Continued

- b. Repair by replacing Fresh Water Pump. (Figure 4-19.)

WARNING

Sink assembly power cable must be disconnected prior to performing any maintenance. Failure to do so may result in DEATH or serious injury.

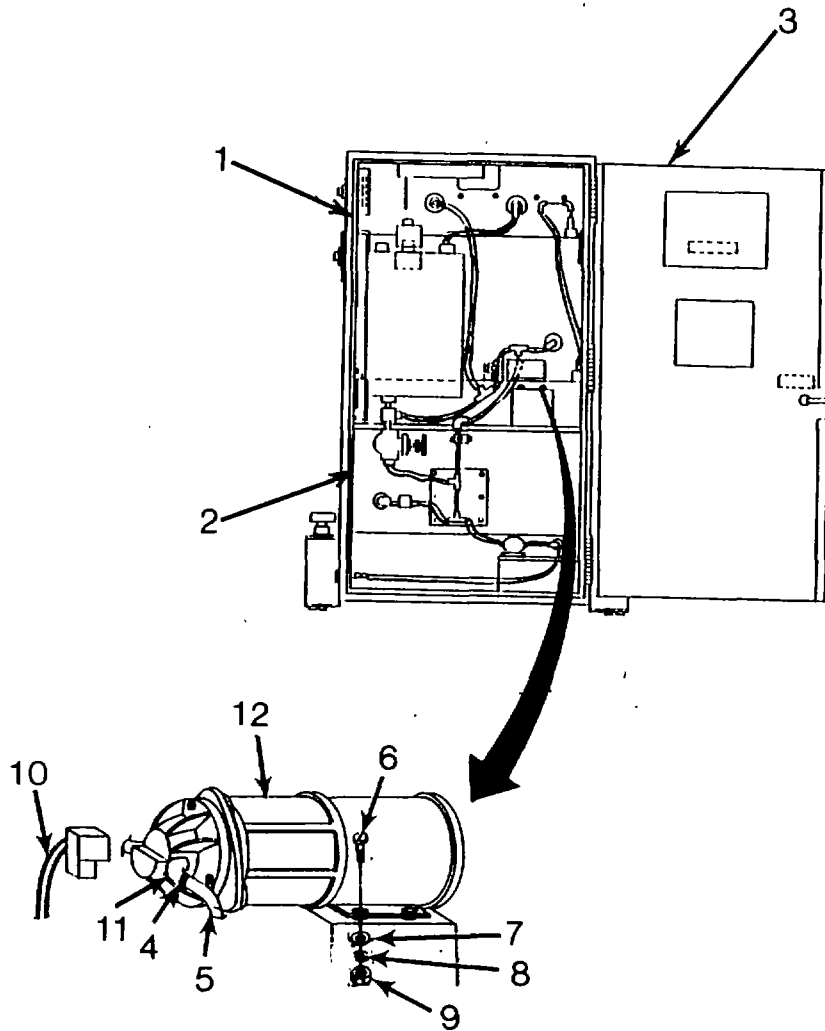

Figure 4-19. Replace Fresh Water Pump

4-22. SINK ASSEMBLY. - Continued

- (1) Drain fresh water tank (1) and grey water tank (2). Refer to paragraph 2-14.

WARNING

Disconnect power to the sink assembly before opening rear door. DEATH on contact may result if power is not disconnected.

- (2) Open rear door (3).
- (3) Remove clamps (4) and hoses (5).
- (4) Remove screws (6), flat washers (7), lockwashers (8), and nuts (9) holding fresh water pump in place.
- (5) Tag and disconnect electrical wires (10).
- (6) Remove elbow fitting (11).
- (7) Remove pump (12).
- (8) Place new pump (12) in position.
- (9) Install elbow fitting (11) and electrical wires (10) and remove tags.
- (10) Secure pump with screws (6), flat washers (7), lockwashers (8), and nuts (9).
- (11) Attach and tighten clamps (4) and hoses (5).
- (12) Close rear door (3).

4-22. SINK ASSEMBLY. - Continued

c. Repair by replacing Drain Pump. (Figure 4-20.)

WARNING

Disconnect power to the sink assembly before opening rear door. DEATH on contact may result if power is not disconnected.

- (1) Place switch S1 on control panel in OFF position.
- (2) Open rear door (1).
- (3) Remove clamps (2) and hoses (3).

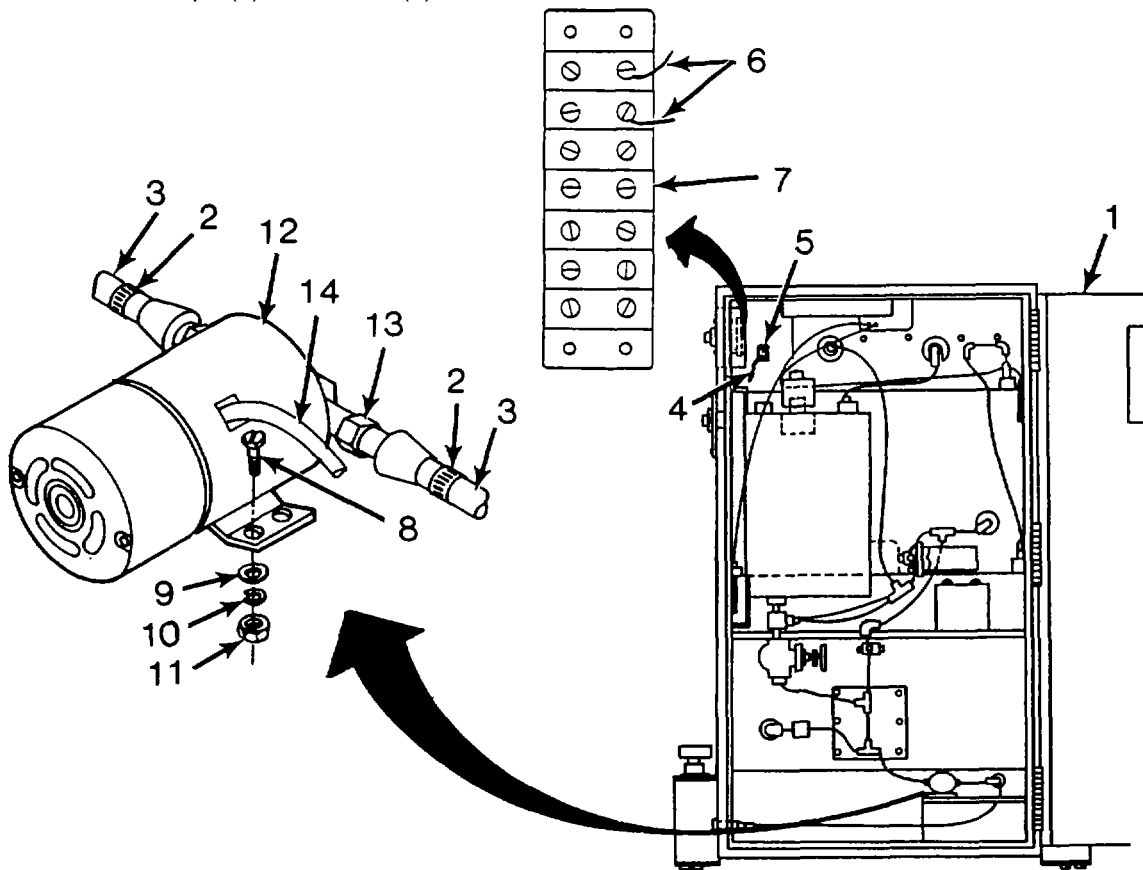

Figure 4-20. Replace Drain Pump

4-22. SINK ASSEMBLY. - Continued

- (4) Clip tie straps and unsolder electrical connection (4) from switch 52 (5).
 - (5) Disconnect green and white wires (6) from terminal board (7).
 - (6) Remove screws (8) flat washers (9), lockwashers (10), and nuts (11).
 - (7) Remove pump (12), remove brass fittings (13), and repair pump if necessary. (See paragraph 4-22.L. below.)
 - (8) Cut and strip cord (14) on new pump (12) to same length as old pump cord (14) and attach terminal lugs to green and white wires (6).
 - (9) Install brass fittings (13) on new pump (12).
 - (10) Place new pump (12) in position.
 - (11) Install screws (8), flat washers (9), lockwashers (10), and nuts (11) holding pump in place.
 - (12) Connect green and white wires (6) to terminal board (7).
 - (13) Solder wire (4) to switch 52 (5) and attach tie straps.
 - (14) Attach hoses (3) and clamps (2).
 - (15) Close rear door (1).
 - (16) Turn power on and test operation.
- d. Repair by replacing Toggle Switch. (Refer to figure 4-21.)

WARNING

Disconnect power to the sink assembly before opening rear door. DEATH on contact may result if power is not disconnected.

4-22. SINK ASSEMBLY. - Continued

NOTE

This procedure applies to replacing any of the switches on the sink assembly control panel.

- (1) Open rear door (1).
- (2) Tag and disconnect switch terminal wires (2).
- (3) Remove switch mounting nut (3).
- (4) Remove switch (4).
- (5) Place new switch (4) in position.
- (6) Install switch mounting nut (3).
- (7) Connect switch terminal wires (2) and remove tags.

4-22. SINK ASSEMBLY. - Continued

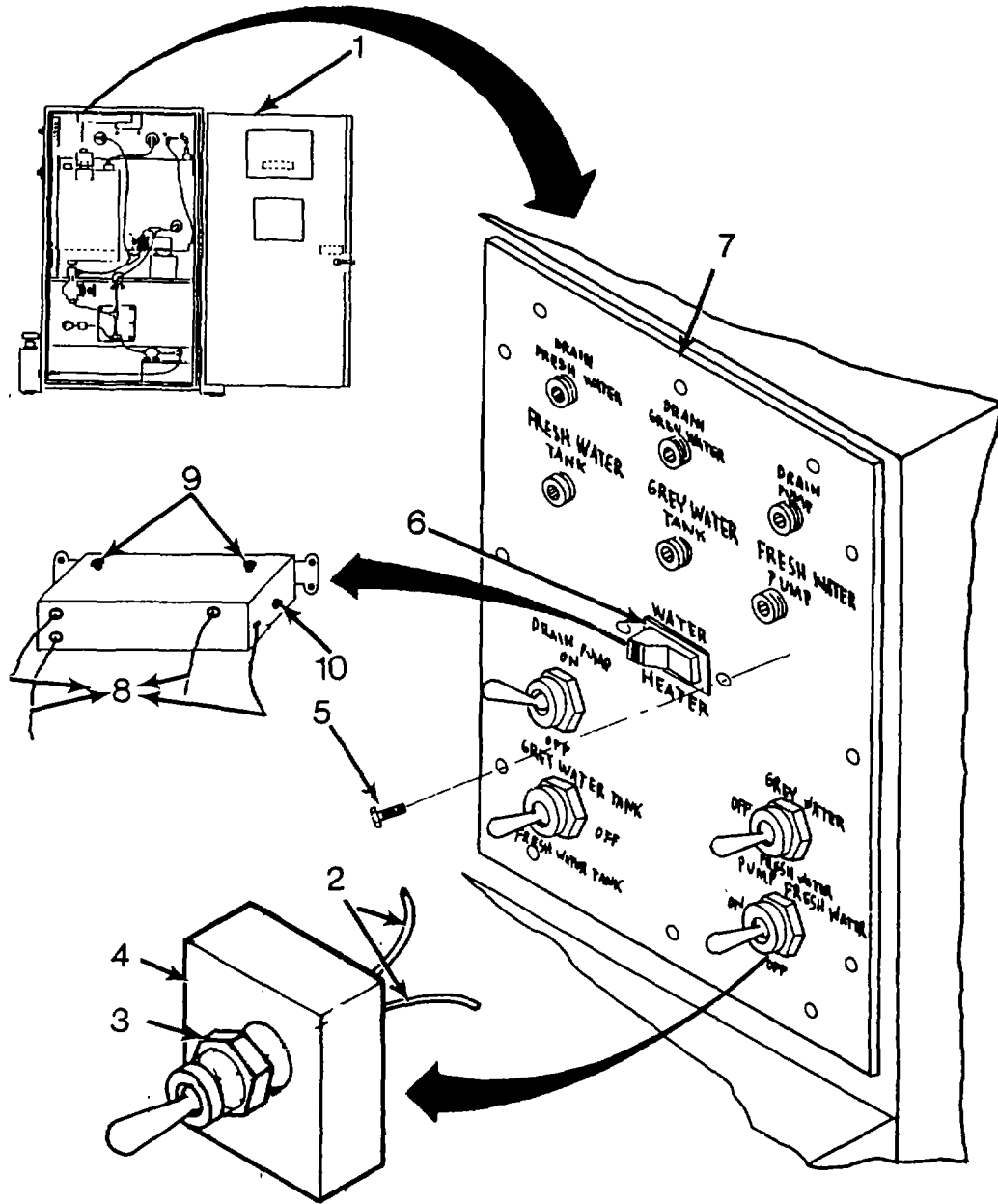

Figure 4-21. Replace Switch

4-22. SINK ASSEMBLY. - Continued

(8) Close rear door (1).

e. Repair by replacing water heater switch. (See figure 4-21.)

WARNING

Disconnect power to the sink assembly before opening rear door. DEATH on contact may result if power is not disconnected.

(1) Open rear door (1).

(2) Remove screws (5).

(3) Push water heater switch (6) away from control panel (7).

(4) Tag and disconnect switch terminal wires (8) by loosening screws (9) and removing screw (10).

(5) Remove water heater switch (6).

(6) Loosen screws (9) and remove screw (10) from new water heater switch (6).

(7) Connect switch terminal wires (8) by tightening screws (9) and installing screw (10).

(8) Position water heater switch (6) on control panel (7).

(9) Install screws (5).

(10) Close rear door (1).

4-22. SINK ASSEMBLY. - Continued

f. Repair by replacing Power Supply. (Figure 4-22.)

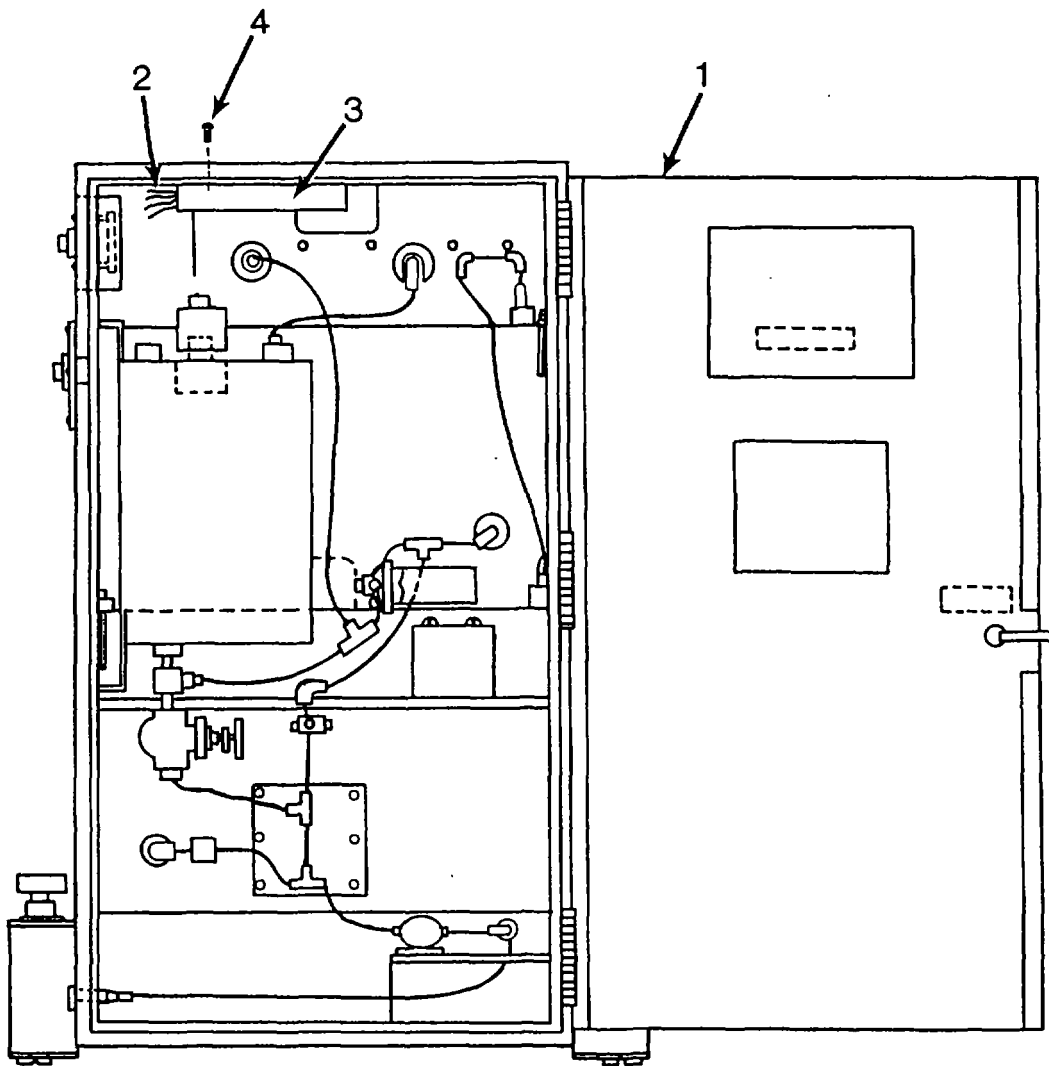

Figure 4-22. Replace Power Supply

4-22. SINK ASSEMBLY. - Continued

WARNING

Disconnect power to the sink assembly before opening rear door. DEATH on contact may result if power is not disconnected.

- (1) Open rear door (1).
- (2) Tag and disconnect terminal wires (2) attached to power supply (3).
- (3) Remove screws (4) holding power supply (3) in place.
- (4) Remove power supply (3).
- (5) Place new power supply (3) in position.
- (6) Apply RTV sealing compound to seal screws (4).
- (7) Install screws (4) holding power supply (3) in place.
- (8) Connect terminal wires (2) and remove tags.
- (9) Close rear door (1).
- (10) Turn power on and test operation.

4-22. SINK ASSEMBLY. - Continued

g. Repair by Replacing Fuse Holder. (Figure 4-23.)

- (1) Remove fuse (1) from fuse holder (2) by rotating counterclockwise.

WARNING

Disconnect power to the sink assembly before opening rear door. DEATH on contact may result if power is not disconnected.

- (2) Open rear door (3).
- (3) Tag and unsolder wires (4).
- (4) Remove nut (5) and push fuse holder (2) out.
- (5) Position new fuse holder (2) and install nut (5).

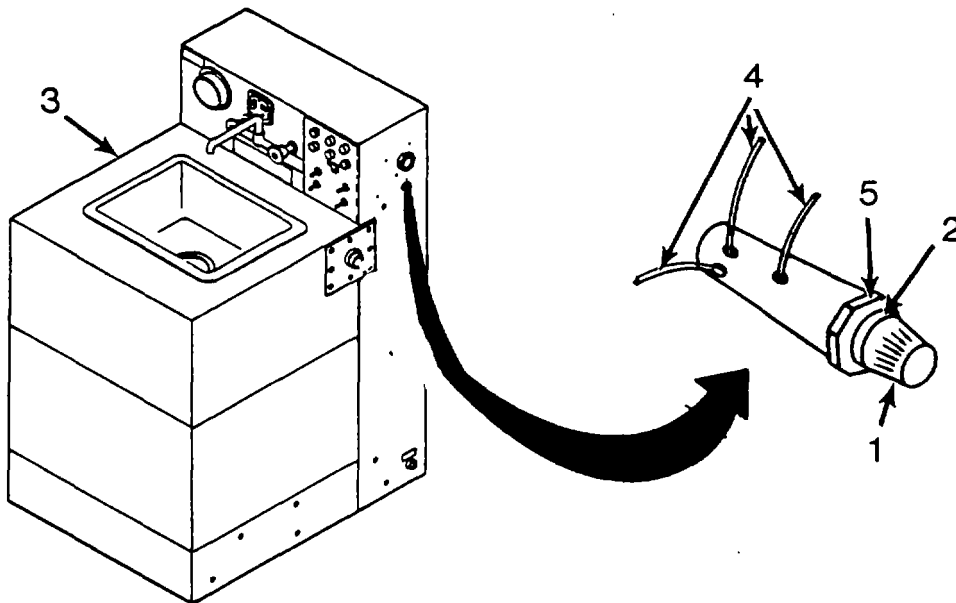

Figure 4-23. Replace Fuse Holder

4-22. SINK ASSEMBLY. - Continued

- (6) Solder wires (4) and remove tags.
- (7) Install fuse (1) and close rear door (3).
- (8) Turn on power and test operation.

h. Repair by replacing Water Heater. (Figure 4-24.)

- (1) Drain fresh water tank. Refer to paragraph 2-14.

WARNING

Disconnect power to the sink assembly before opening rear door. DEATH on contact may result if power is not disconnected.

- (2) Open rear door (1).
- (3) Remove clamp (2) and hose (3).
- (4) Remove nuts (4), lockwashers (5), flat washers (6), and bolts (7).
- (5) Pull temperature indicator knob (8) off.
- (6) Loosen two screws (9) and remove heater cover (10).
- (7) Loosen bracket (11), loosen screws (12), and disconnect wires (13).
- (8) Loosen nut (14) and remove temperature probe (15).
- (9) Remove clamps (16) and hoses (17).
- (10) Remove valve (18).
- (11) Remove hot water tank (19).
- (12) Remove heater by unscrewing nut (20).

4-22. SINK ASSEMBLY. - Continued

- (13) Wrap new heater threads with thread seal tape.
- (14) Screw new heater in place.
- (15) Install hot water tank (19).
- (16) Install valve (18), hoses (17), and clamps (16).
- (17) Install temperature probe (15) and tighten nut (14).
- (18) Connect wires (13), tighten screw (12), and tighten bracket (11).
- (19) Put heater cover (10) on and tighten screws (9).
- (20) Push temperature indicator knob (8) on.
- (21) Secure hot water tank (19) with nuts (4), lockwashers (5), flat washers (6) and bolts (7).
- (22) Install clamp (2) and hose (3).
- (23) Close rear door.
- (24) Turn on power and test operation.

4-22. SINK ASSEMBLY. - Continued

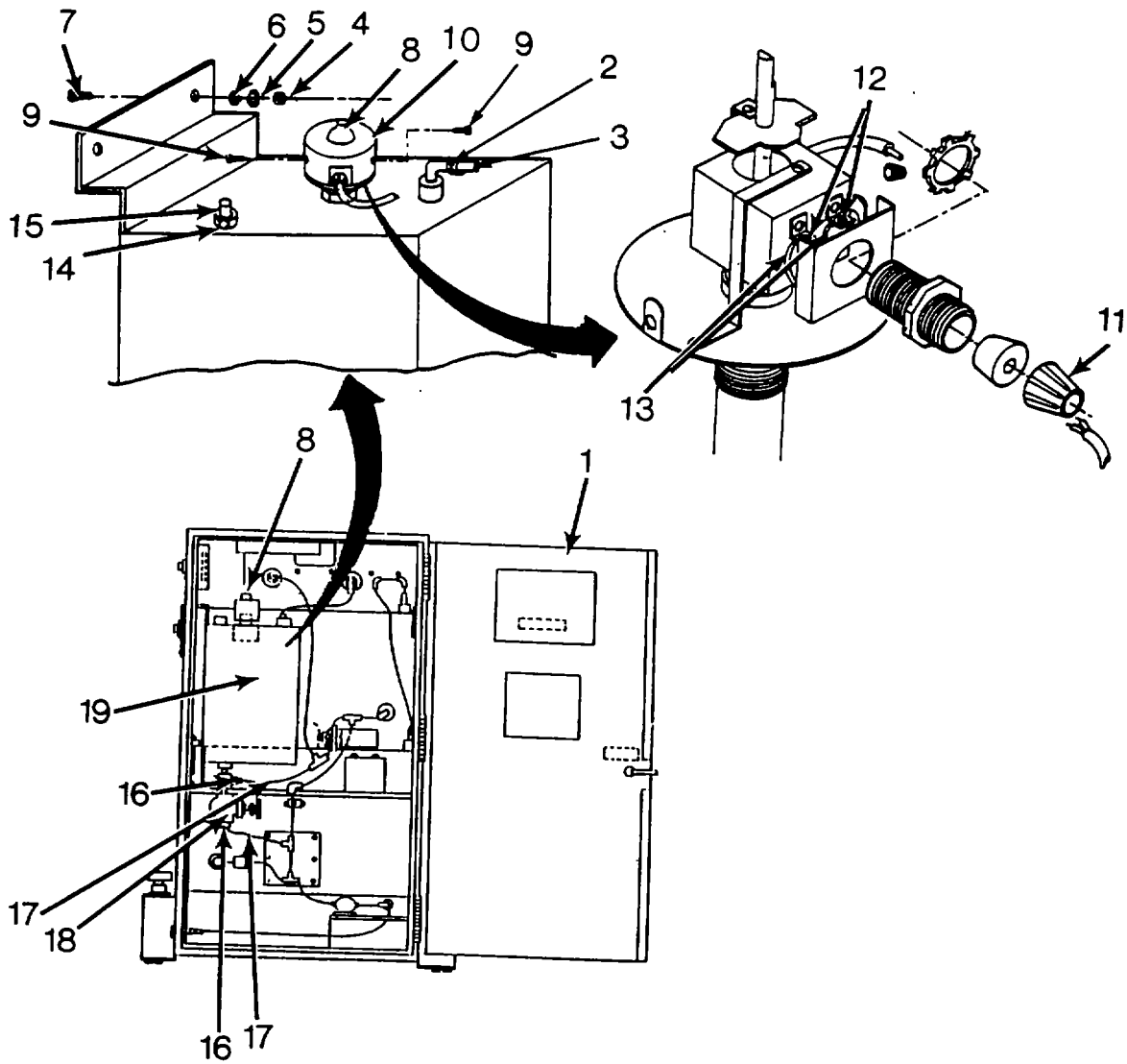

Figure 4-24. Replace Water Heater

4-22. SINK ASSEMBLY. - Continued

- i. Repair by replacing Water Level Monitor. (Figure 4-25.)

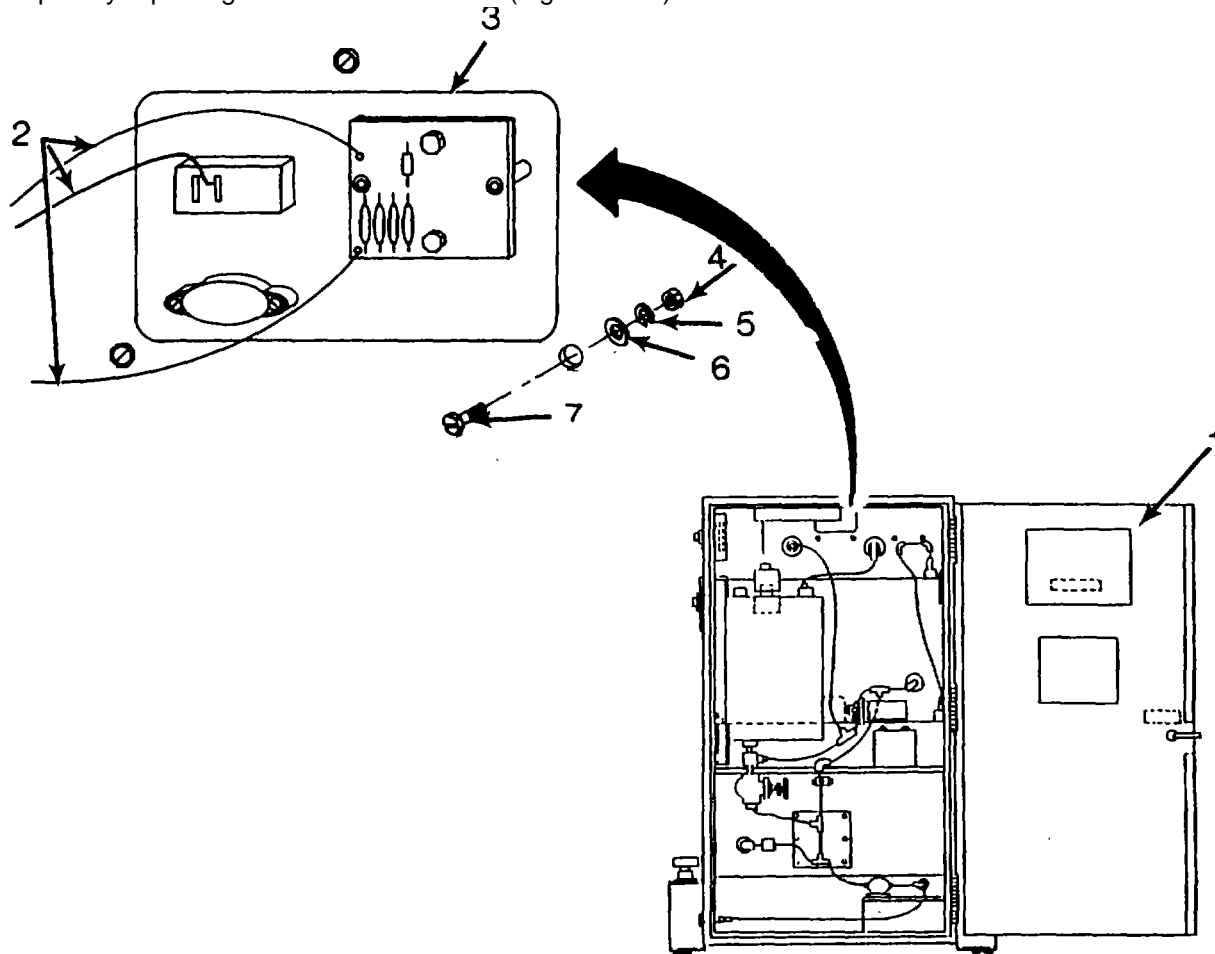

Figure 4-25. Replace Water Level Monitor

- (1) Drain fresh water tank and grey water tank. Refer to paragraph 2-14.

WARNING

Disconnect power to the sink assembly before opening rear door. DEATH on contact may result if power is not disconnected.

- (2) Open rear door (1).

4-22. SINK ASSEMBLY. - Continued

- (3) Tag and disconnect terminal wires (2) from water level monitor (3).
 - (4) Remove nuts (4), lockwashers (5), flat washers (6), and screws (7) holding water level monitor in place.
 - (5) Remove water level monitor (3).
 - (6) Place new water level monitor (3) in place.
 - (7) Install screws (7), flat washers (6), lockwashers (5), and nuts (4) holding water level monitor (3) in place.
 - (8) Connect terminal wires (2) to water level monitor (3) and remove tags.
 - (9) Close rear door (1).
 - (10) Turn on power and test operation.
- j. Repair by replacing Fresh Water or Grey Water Tank Level Probe. (Figure 4-26.)
- (1) Drain water tank (1). Refer to paragraph 2-14.

WARNING

Disconnect power to the sink assembly before opening rear door. DEATH on contact may result if power is not disconnected.

NOTE

Hot water tank must be removed before removing gray water tank level probe. (See h. above.)

- (2) Open rear door (2).
- (3) Loosen top nut (3) on water tank level probe (5).
- (4) Disconnect terminal wire (4) to water tank level probe (5).
- (5) Loosen bottom nut (6) on water tank level probe (5).

4-22. SINK ASSEMBLY. - Continued

NOTE

Water level probe is flexible and may be bent when removing and installing.

- (6) Lift tank level probe (5) out of water tank (1).
- (7) Place spring holder (7) in upper part of level probe (5) and cut off new level probe (5) to same length as old level probe (5).
- (8) Place spring holder (7) on bottom of level probe (5).
- (9) Apply RTV sealing compound (Appendix E, item 33) to rubber grommet (8).
- (10) Insert new tank level probe (5) into water tank (1).
- (11) Tighten bottom nut (6) on tank level probe. Do not over tighten.
- (12) Connect terminal wire (4) to tank level probe (5).
- (13) Tighten top nut (3) on water tank level probe (5).
- (14) Close rear door (2).
- (15) Turn on power, test operation and adjust water level on water level monitor by filling tank and turning indicator adjustment (9) to full.

4-22. SINK ASSEMBLY. - Continue

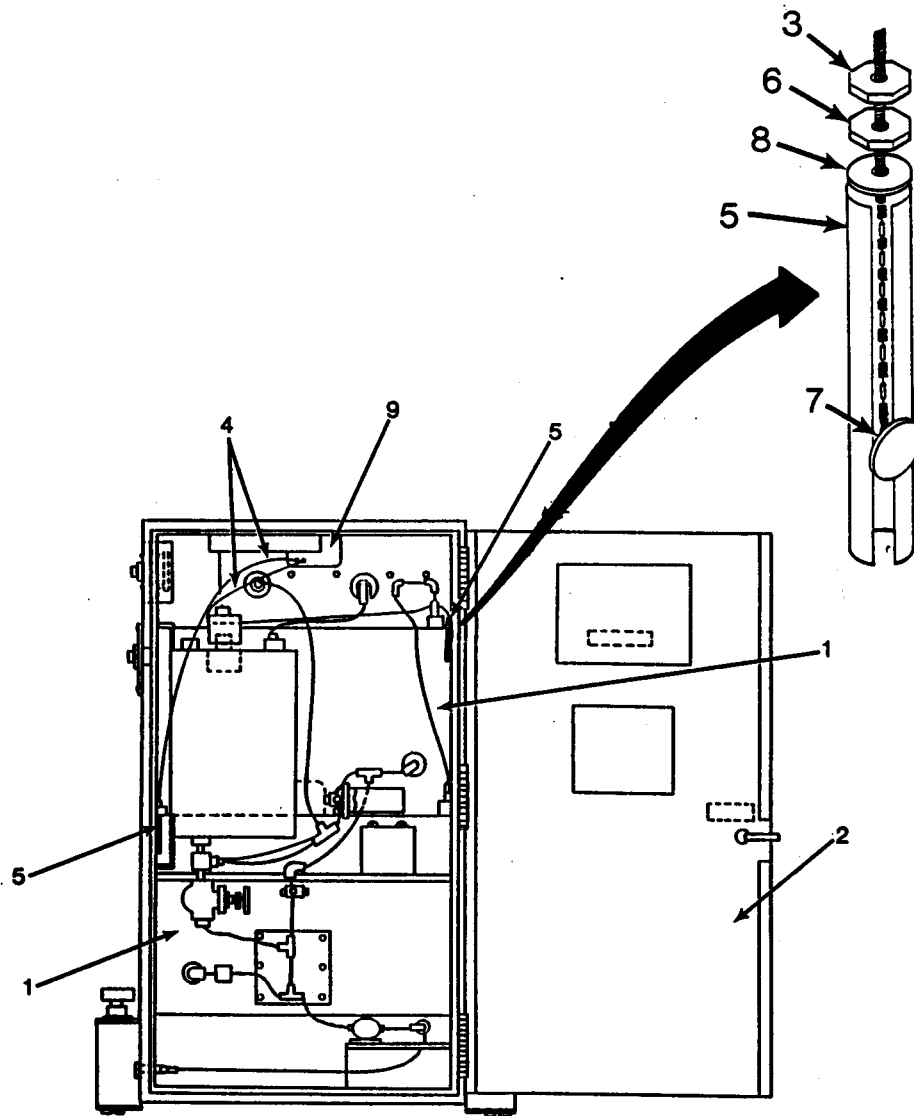

Figure 4-26. Replace Fresh Water and Grey Water Tank Level Probe

4-22. SINK ASSEMBLY. - Continued

k. Repair by replacing Fresh Water or Gray Water Drain Solenoid. (Figure 4-27.)

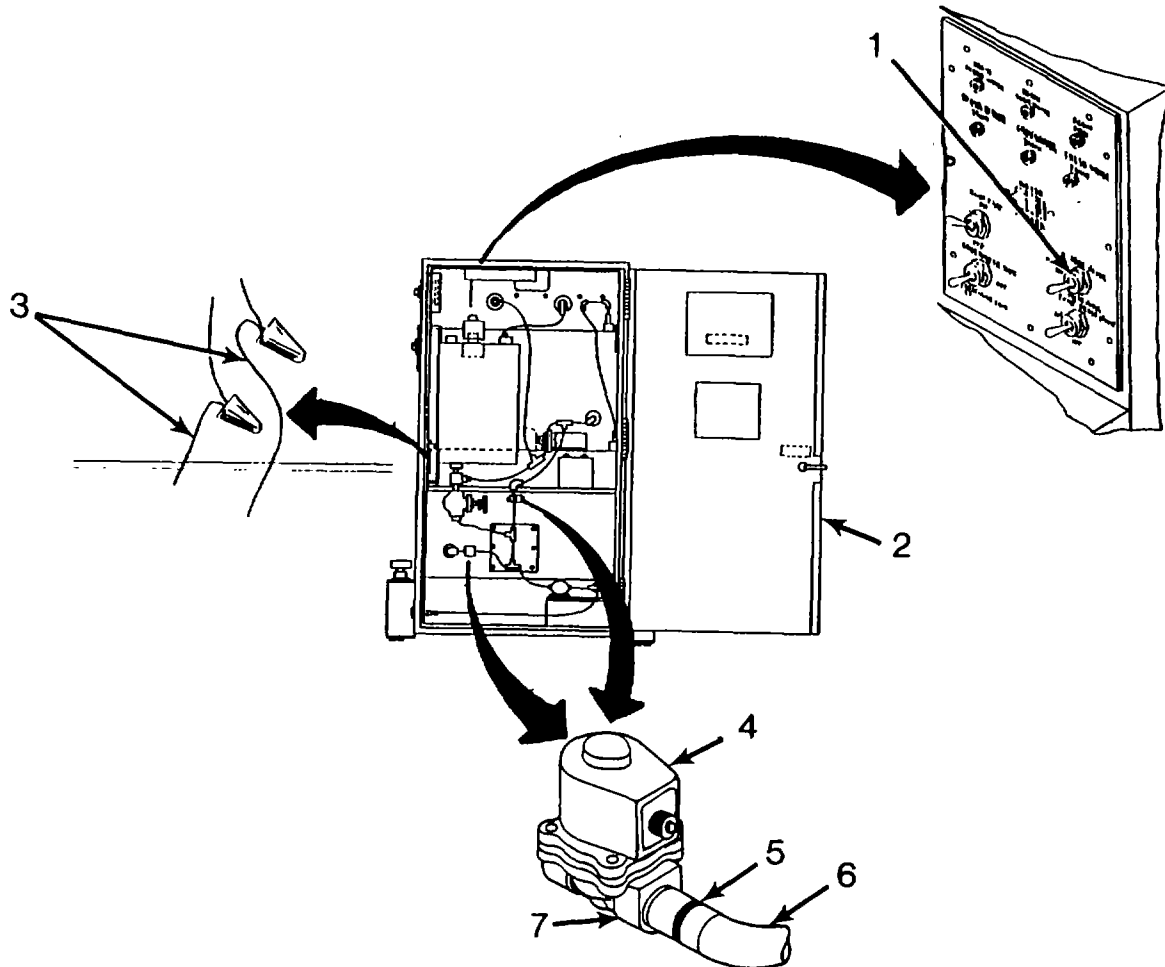

Figure 4-27. Replace Fresh Water or Gray Water Drain Solenoid

WARNING

Disconnect power to the sink assembly before opening rear door. DEATH on contact may result if power is not disconnected.

- (1) Place switch S1 (1) in OFF position.
- (2) Open rear door (2).

4-22. SINK ASSEMBLY. - Continued

- (3) Tag and disconnect solenoid wires (3) leading from the solenoid (4).
 - (4) Remove clamp (5) and hose (6).
 - (5) Unscrew solenoid (4).
 - (6) Remove plastic fitting (7) from solenoid (4).
 - (7) Apply RTV sealing compound (Appendix E, item 33) to plastic fitting (7) and install plastic fitting (7) on solenoid (4).
 - (8) Apply RTV sealing compound. Screw solenoid (4) in place.
 - (9) Connect solenoid wires (3) and remove tags.
 - (10) Install hose (6) and clamp (5).
 - (11) Close rear door (2).
 - (12) Turn on power and test operation.
- i. Repair Drain Pump by Replacing Impeller. (See Figure 4-28.)
- (1) Disconnect clamps (1) and hoses (2).
 - (2) Remove nuts (3), lockwashers (4), flat washers (5), and screws (6) holding drain pump (7) in place.
 - (3) Remove brass fittings (8).
 - (4) Remove screws (9), plate (10), gasket (11), and impeller (12) from drain pump (7).

NOTE

Coat new impeller with petroleum jelly (Appendix E, item 35) before installing.

- (5) Install new impeller (12), new gasket (11), plate (10), and screws (9).

4-22. SINK ASSEMBLY. - Continued

- (6) Install brass fittings (8).
- (7) Install nuts (3), lockwashers (4), flat washers (5), and screws (6) holding drain pump (7) in place.
- (8) Install clamps (1) and hoses (2).

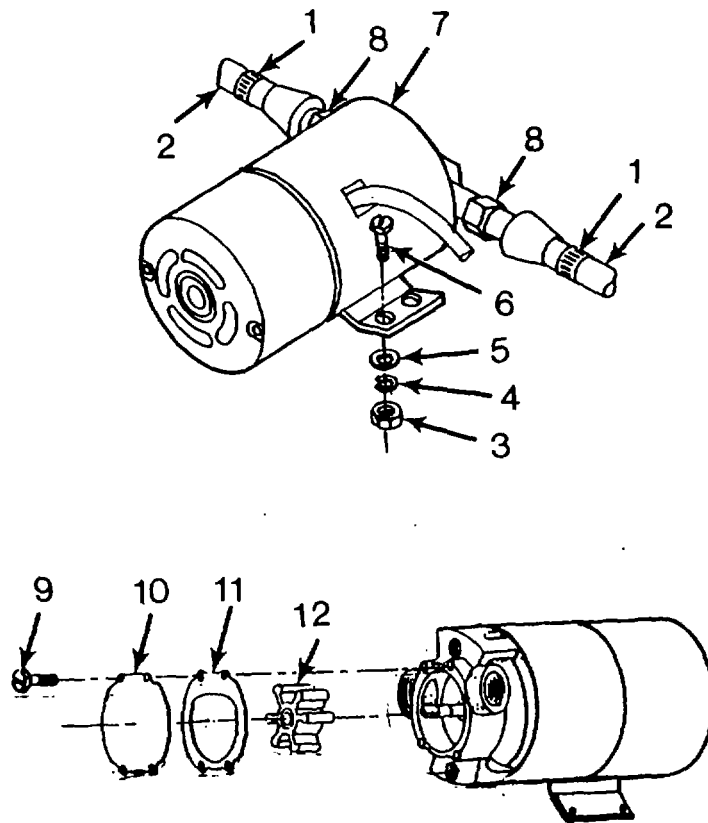

Figure 4-28. Replace Drain Pump Impeller

4-22. SINK ASSEMBLY. - Continued

m. Repair by replacing water float valve assembly. (See Figure 4-29.)

(1) Drain fresh water tank. Refer to paragraph 2-14.

WARNING

Disconnect power to the sink assembly before opening rear door. DEATH on contact may result if power is not disconnected.

(2) Remove screws (1) and pull water float valve assembly out of sink assembly.

(3) Remove float (2).

(4) Remove float rod (3).

(5) Remove float valve (4) and RTV sealant. (Appendix E, item 33.)

(6) Apply thread sealing tape (Appendix E, item 36) and install float valve (4).

(7) Install float rod (3) and float (2).

(8) Adjust float valve assembly so that top of float (2) is one inch below top of access plate (5) in closed position.

(9) Apply RTV sealing compound (item 33) to access plate (5) and position float valve assembly in sink assembly and secure with screws (1).

(10) Turn on power and test operation.

4-22. SINK ASSEMBLY. - Continued

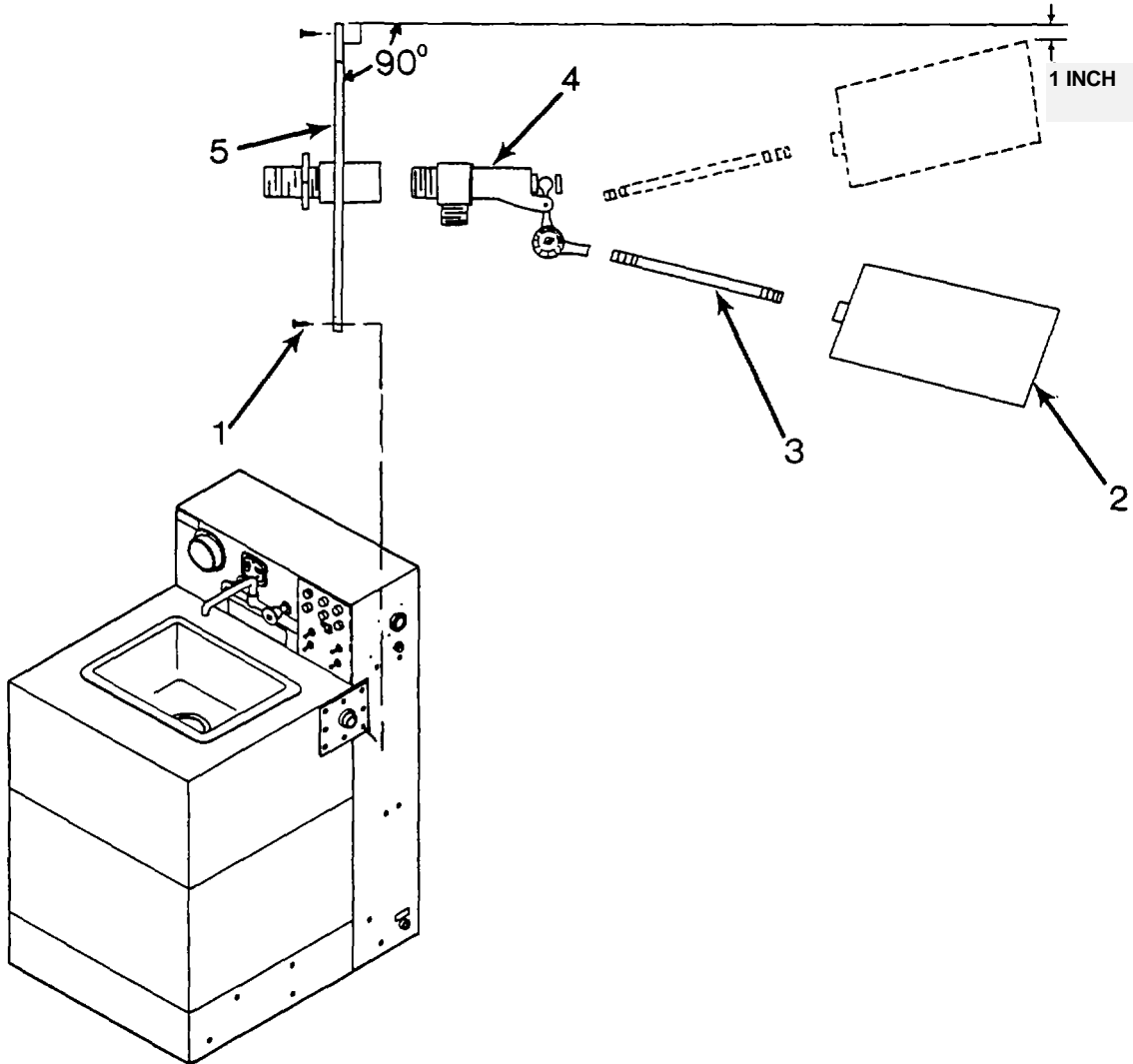

Figure 4-29. Replace Water Float Valve Assembly

n. Repair by replacing Ground Fault Interrupter (GFI) Receptacle. (See Figure 4-30.)

(1) Open rear door (1).

WARNING

Disconnect power to the sink assembly before opening rear door. DEATH on contact may result if power is not disconnected.

4-22. SINK ASSEMBLY. - Continued

- (2) Unplug plugs (2).
- (3) Remove screws (3) and face plate (4).
- (4) Remove screws (5) and pull out GFI receptacle (6).
- (5) Loosen screws (7) and tag and disconnect wires (8).
- (6) Remove GFI receptacle (6).
- (7) Connect wires (8) to new GFI receptacle (6) by tightening screws (7).
- (8) Position GFI receptacle (6) and secure with screws (5).
- (9) Position face plate (4) and secure with screws (3).
- (10) Connect plugs (2).
- (11) Close rear door (1).
- (12) Turn on power and test operation.

4-22. SINK ASSEMBLY. - Continued

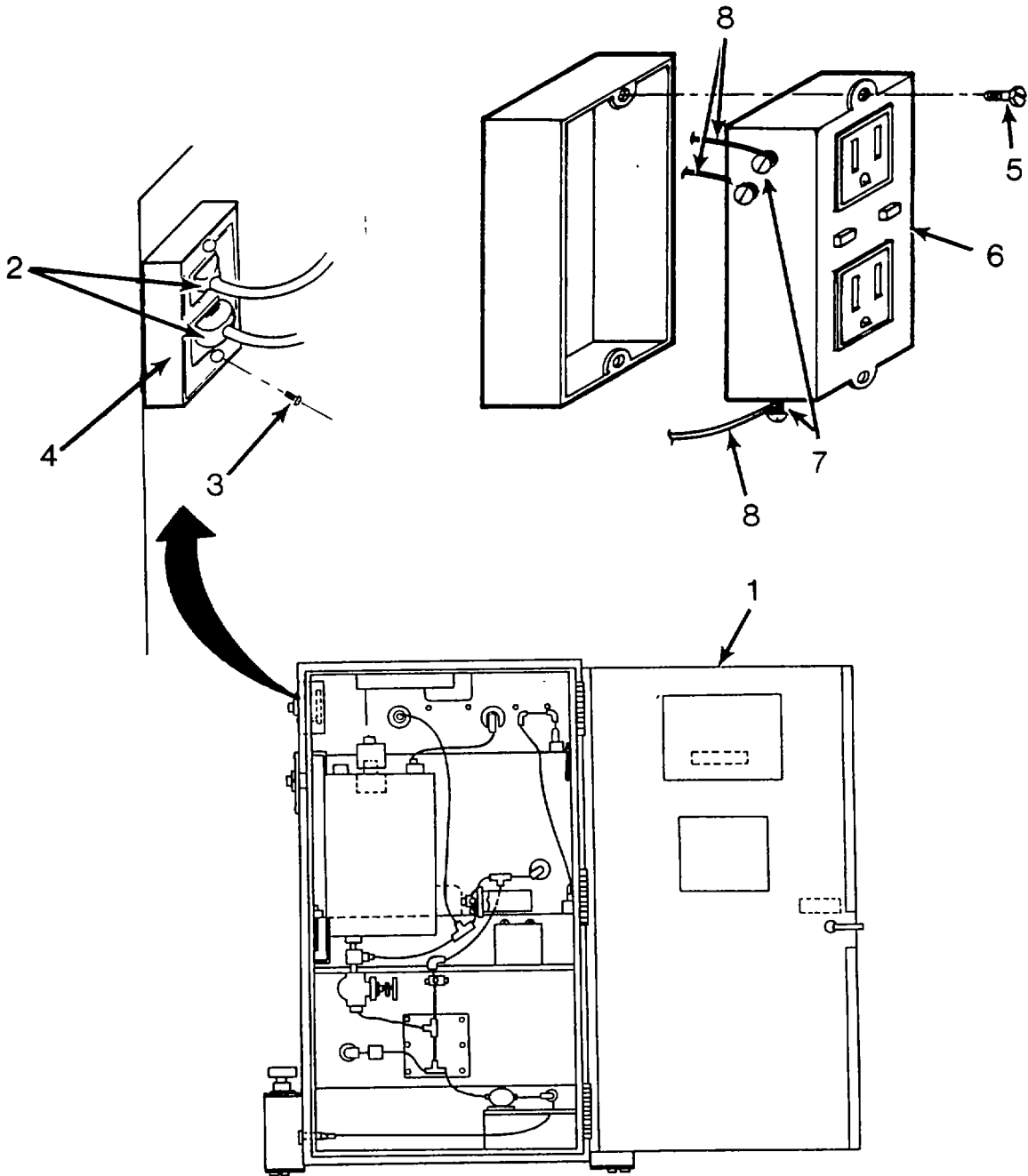

Figure 4-30. Replace GFI Receptacle

4-22. SINK ASSEMBLY. - Continued

- o. Repair by replacing transporter assembly. (See Figure 4-31.)
 - (1) Drain fresh water and gray water tanks. Refer to paragraph 2-14.

WARNING

Disconnect power to the sink assembly before opening rear door. DEATH on contact may result if power is not disconnected.

- (2) Using control knob (1), lower sink assembly to floor of shelter.

WARNING

Two people are required to lay sink assembly on its front. Failure to do so may result in serious injury.

- (3) Lay sink assembly on its front to avoid damaging electrical equipment.
- (4) Remove nuts (2), lockwashers (3), flat washers (4), and bolts (5) securing transporter assembly (6) to sink assembly and remove transporter assembly (6).
- (5) Position holes in replacement transporter assembly (6) with holes in sink assembly and secure with bolts (5), flat washers (4), lockwashers (3), and nuts (2).
- (6) Raise sink assembly to upright position.

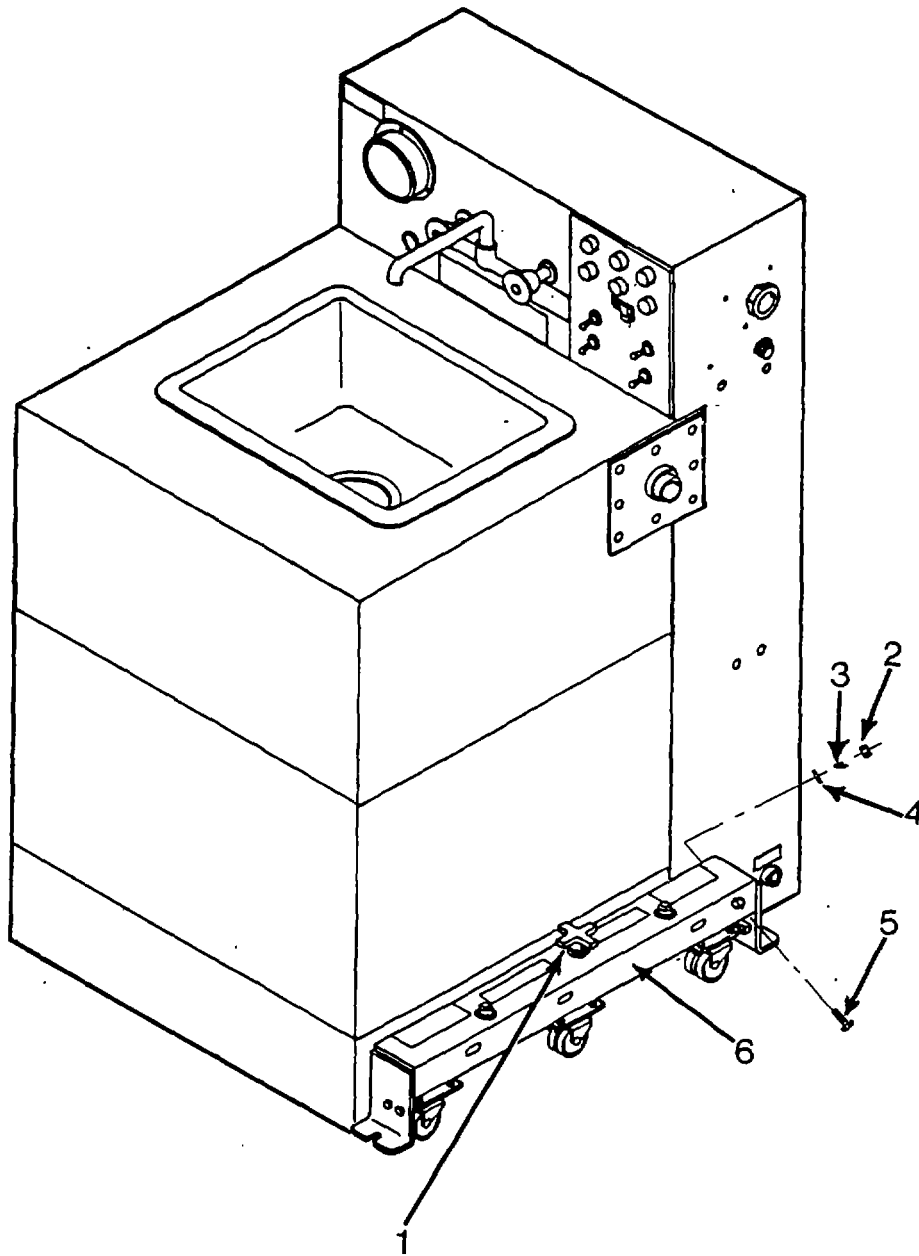

Figure 4-31. Replace Transporter Assembly

4-23. PAPER JOGGING CABINET ASSEMBLY. Refer to figure 4-32 for location of components and hardware of the paper jogging cabinet assembly.

This task covers: Repair

INITIAL SETUP

Tools

General Mechanics Automotive Tool Kit, Appendix B

Materials

None

- a. Repair paper jogging cabinet assembly.
 - (1) Tighten or replace loose or missing bolts, nuts, washers, or top assembly on cabinet (1).
 - (2) Tighten or replace loose or missing bolts, nuts or washers on transporter assembly (2).

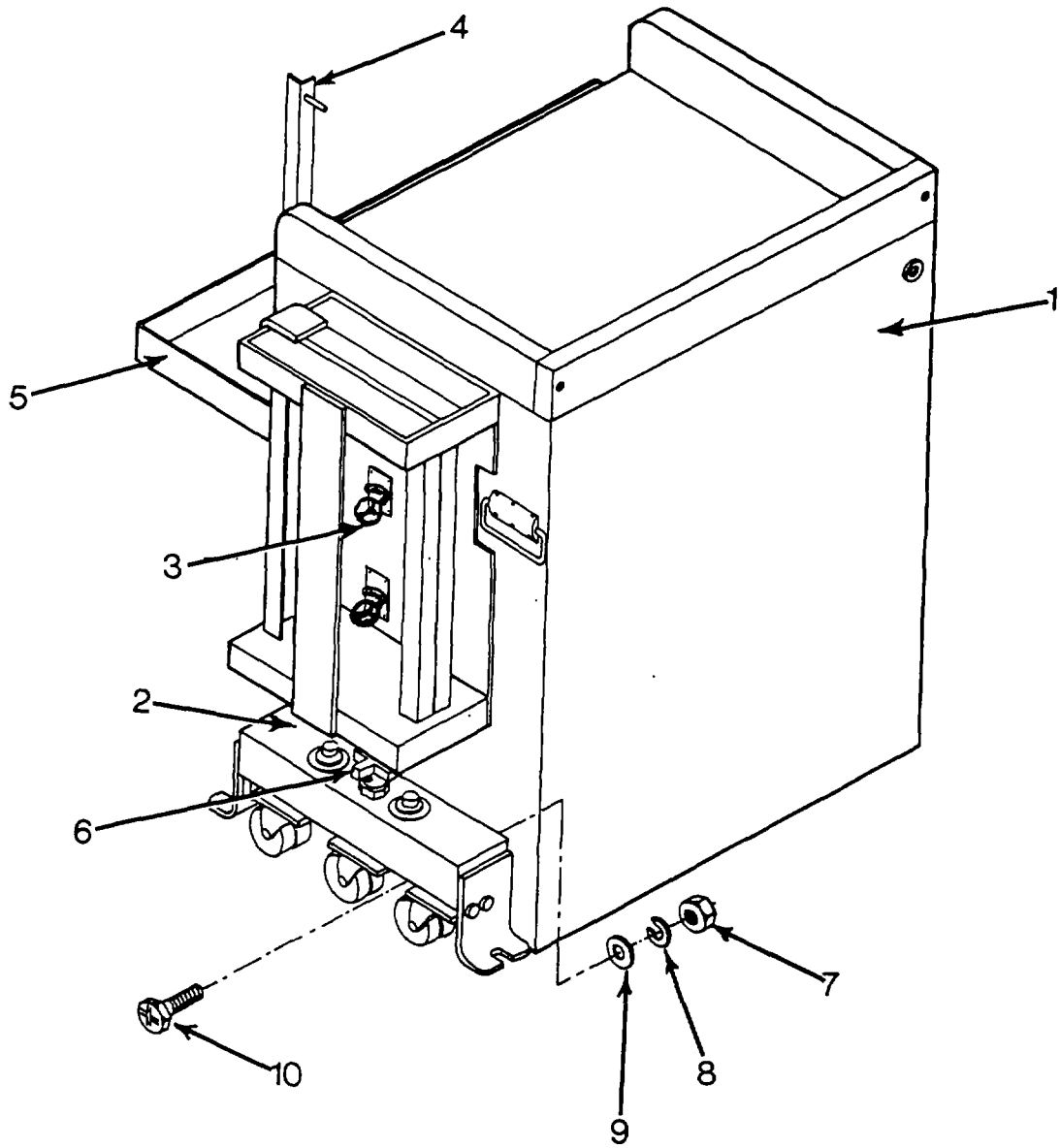

Figure 4-32. Paper Jogging Cabinet Assembly.

4-23. PAPER JOGGING CABINET ASSEMBLY. - Continued

b. Repair by replacing.

(1) Remove delivery boards (3).

(2) Remove shipping bracket (4) and drawers (5).

(3) Using control knob (6) on transporter assembly (2), lower paper jogging cabinet assembly to floor of shelter.

WARNING

**Two people are required to lay paper jogging cabinet assembly on its back.
Failure to do so may result in serious injury.**

(4) Lay paper jogging cabinet assembly on its back.

(5) Remove nuts (7), lockwashers (8), flat washers (9), and bolts (10) securing transporter assembly to cabinet assembly and remove transporter assembly (2).

(6) Position holes in replacement transporter assembly (2) with holes in cabinet assembly and secure in place with bolts (10), flat washers (9), lockwashers (8) and nuts (7).

(7) Raise paper jogging cabinet assembly to upright position.

(8) Install drawers (5) and shipping brackets (4).

(9) Install delivery boards (3).

4-24. WORK TRANSFER CART. Refer to figure 4-33 for location of components and hardware of work transfer cart.

This task covers: Repair

INITIAL SETUP

Tools

General Mechanics Automotive Tool Kit

Materials

None

- a. Repair by replacing shelves (1).

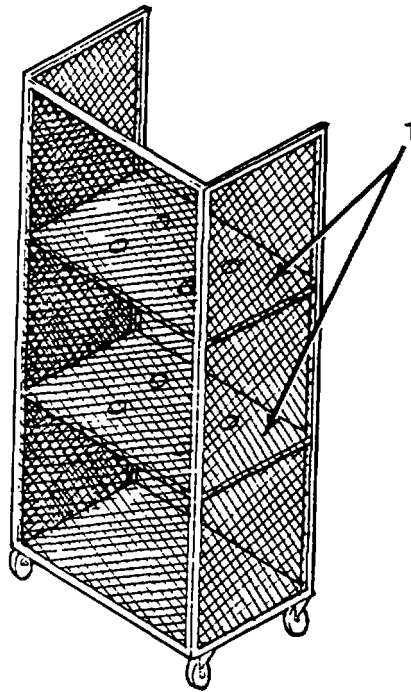

Figure 4-33. Work Transfer Cart

4-25. COMPLEXING KIT. The complexing kit provides a covered passageway from the Press Section Shelters to the Finishing Section Shelter. Refer to TM 10-5411-203-13/23P for repair procedures on the complexing kit.

4-26. ISO SHELTER. The ISO shelter is a standard Army expandable shelter that houses the components of the Press Section. Refer to TM 10-5411-200-14 for repair procedures on the ISO shelter.

4-27. PHASE MONITOR METER. Refer to figure 4-34 for location of components and hardware of the phase monitor meter.

This task covers: a. Repair

INITIAL SETUP

Tools

Electrical Equipment Tool Kit

Materials

None

WARNING

The main power cable to the Press Section MUST be disconnected before performing any maintenance on the phase monitor meter. Failure to do so may result in DEATH or serious injury.

- a. Repair by replacing voltage meter.
 - (1) Remove phase monitor meter (1) from wall by removing screws (2), lockwashers (3) and flat washers (4).
 - (2) Tag and disconnect wires (5).

4-27. PHASE MONITOR METER. - Continued

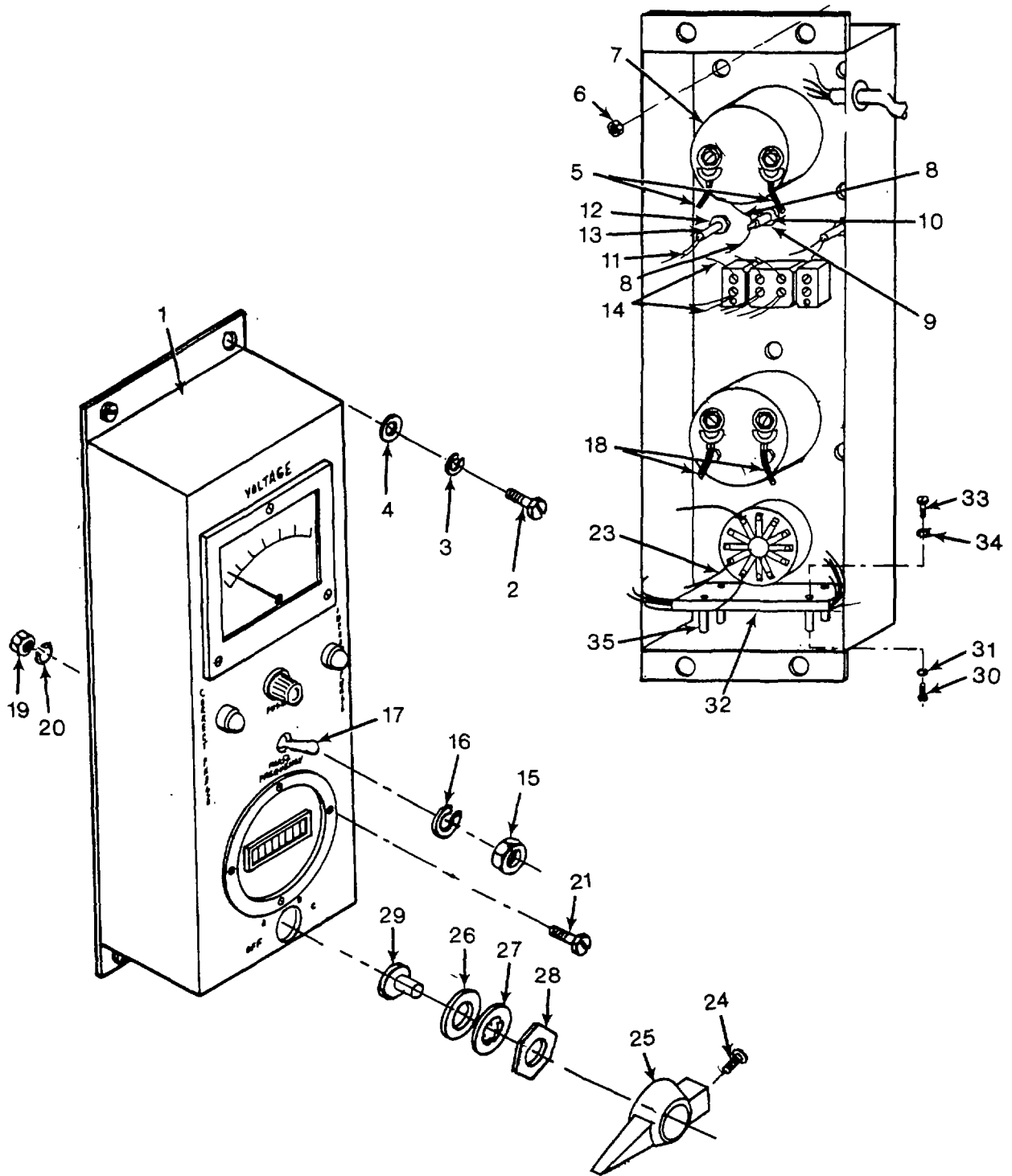

Figure 4-34. Repair Phase Monitor Meter

4-27. PHASE MONITOR METER. - Continued

- (3) Remove nuts (6) and voltage meter (7).
 - (4) Position replacement voltage meter (7) and secure with nuts (6).
 - (5) Connect wires (5) and remove tags.
 - (6) Attach phase monitor meter (1) to shelter wall by securing flat washers (4), lockwashers (3), and screws (2).
 - (7) Turn on power and test operation.
- b. Repair by replacing fuse holder.

WARNING

The main power cable to the Press Section MUST be disconnected before performing any maintenance on the phase monitor meter. Failure to do so may result in DEATH or serious injury.

- (1) Remove phase monitor meter (1) from wall by removing screws (2), lockwashers (3) and flat washers (4).
- (2) Tag and unsolder wires (8).
- (3) Remove nut (9) and fuse holder (10).
- (4) Position replacement fuse holder (10) and secure with nut (9).
- (5) Solder wires (8) and remove tags.
- (6) Attach phase monitor meter (1) to shelter wall by securing flat washers (4), lockwashers (3), and screws (2).
- (7) Turn on power and test operation.

4-27. PHASE MONITOR METER. - Continued

- c. Repair by replacing correct/incorrect phase indicator lights.

WARNING

The main power cable to the Press Section MUST be disconnected before performing any maintenance on the phase monitor meter. Failure to do so may result in DEATH or serious injury.

NOTE

The procedure is the same for both phase indicator lights.

- (1) Remove phase monitor meter (1) from wall by removing screws (2), lockwashers (3) and flat washers (4).
 - (2) Tag and unsolder wires (11).
 - (3) Remove nut (12) and phase indicator light (13).
 - (4) Position replacement phase indicator light (13) and secure with nut (12).
 - (5) Solder wires (11) and remove tags.
 - (6) Attach phase monitor meter (1) to shelter wall by securing flat washers (4), lockwashers (3), and screws (2).
 - (7) Turn on power and test operation.
- d. Repair by replacing phase test switch.

WARNING

The main power cable to the Press Section MUST be disconnected before performing any maintenance on the phase monitor meter. Failure to do so may result in DEATH or serious injury.

4-27. PHASE MONITOR METER. - Continued

- (1) Remove phase monitor meter (1) from wall by removing screws (2), lockwashers (3) and flat washers (4).
 - (2) Tag and unsolder wires (14).
 - (3) Remove nut (15), lockwasher (16), and phase test switch (17).
 - (4) Position replacement phase test switch (17) and secure with lockwasher (16) and nut (15).
 - (5) Solder wires (14) and remove tags.
 - (6) Attach phase monitor meter (1) to shelter wall by securing flat washers (4), lockwashers (3), and screws (2).
 - (7) Turn on power and test operation.
- e. Repair by replacing frequency meter.

WARNING

The main power cable to the Press Section MUST be disconnected before performing any maintenance on the phase monitor meter. Failure to do so may result in DEATH or serious injury.

- (1) Remove phase monitor meter (1) from wall by removing screws (2), lockwashers (3) and flat washers (4).
- (2) Tag and disconnect wires (18).
- (3) Remove nuts (19), lockwashers (20), screws (21), and frequency meter (22).
- (4) Position replacement frequency meter (22) and secure with screws (21), lockwashers (20), and nuts (19).
- (5) Connect wires (18) and remove tags.
- (6) Attach phase monitor meter (1) to shelter wall by securing flat washers (4), lockwashers (3), and screws (2).
- (7) Turn on power and test operation.

4-27. PHASE MONITOR METER. - Continued

- f. Repair by replacing phase selector switch.

WARNING

The main power cable to the Press Section MUST be disconnected before performing any maintenance on the phase monitor meter. Failure to do so may result in DEATH or serious injury.

- (1) Remove phase monitor meter (1) from wall by removing screws (2), lockwashers (3) and flat washers (4).
- (2) Tag and unsolder wires (23).
- (3) Loosen screw (24) and remove knob (25).
- (4) Remove nut (26), lockwasher (27), flat washer (28), and phase selector switch (29).
- (5) Position replacement phase selector switch (29) and secure with flat washer (28), lockwasher (27), and nut (26).
- (6) Position knob (25) and tighten screw (24).
- (7) Solder wires (23) and remove tags.
- (8) Attach phase monitor meter (1) to shelter wall by secure flat washers (4), lockwashers (3), and screws (2).

- g. Repair by replacing circuit board.

WARNING

The main power cable to the Press Section MUST be disconnected before performing any maintenance on the phase monitor meter. Failure to do so may result in DEATH or serious injury.

- (1) Remove phase monitor meter (1) from wall by removing screws (2), lockwashers (3) and flat washers (4).

4-27. PHASE MONITOR METER. - Continued

- (2) Tag and unsolder wires (11) from the phase indicator lights (13), and only the top row of wires (14) from the phase test switch (17).
- (3) Remove screws (30), lockwashers (31), and circuit board (32).
- (4) Remove screws (33), lockwashers (34), and stand offs (35) from circuit board (32).
- (5) Secure stand offs (35) to replacement circuit board (32) with lockwashers (34) and screws (33).
- (6) Position stand offs (35) and secure with lockwashers (31) and screws (30).

NOTE

Use wire color code to tag wires on the new circuit board the same as on the old circuit board.

- (7) Solder wires (11) and only the top row of wires (14) on replacement circuit board (32) to phase indicator lights (13) and phase test switch (17).
- (8) Attach phase monitor meter (1) to shelter wall by securing flat washers (4), lockwashers (3), and screws (2).
- (9) Turn on power and test operation.

4-28. RIFLE RACK ASSEMBLY. Refer to figure 4-35 for location of components and hardware of rifle rack assembly.

This task covers: Repair

INITIAL SETUP

Tools

General Mechanics Automotive Tool Kit, Appendix B

Materials

RTV Adhesive, 33, Appendix B

4-28. RIFLE RACK ASSEMBLY. - Continued

- a. Repair by replacing upper rifle rack. (See Figure 4-35.)
 - (1) Remove caps (1), screws (2), and upper rifle rack (3).
 - (2) Position replacement upper rifle rack (3) over holes and secure with screws (2). Install caps (1).
- b. Repair by replacing lower rifle rack. (See Figure 4-35.)
 - (1) Remove screws (4) and lower rifle rack (5).
 - (2) Position replacement lower rifle rack (5) and secure with screws (4).
- c. Repair by replacing hook and pile fastener. (See Figure 4-35.)
 - (1) Using electric drill, drill out rivets (6) and remove hook and pile fastener (7).
 - (2) Position replacement hook and pile fastener (7) and using blind riveter install rivets (6).
- d. Repair by replacing rubber mat. (See Figure 4-35.)
 - (1) Remove screws (8), lower rifle guide (9), and rubber mat (10).

4-28. RIFLE RACK ASSEMBLY. - Continued

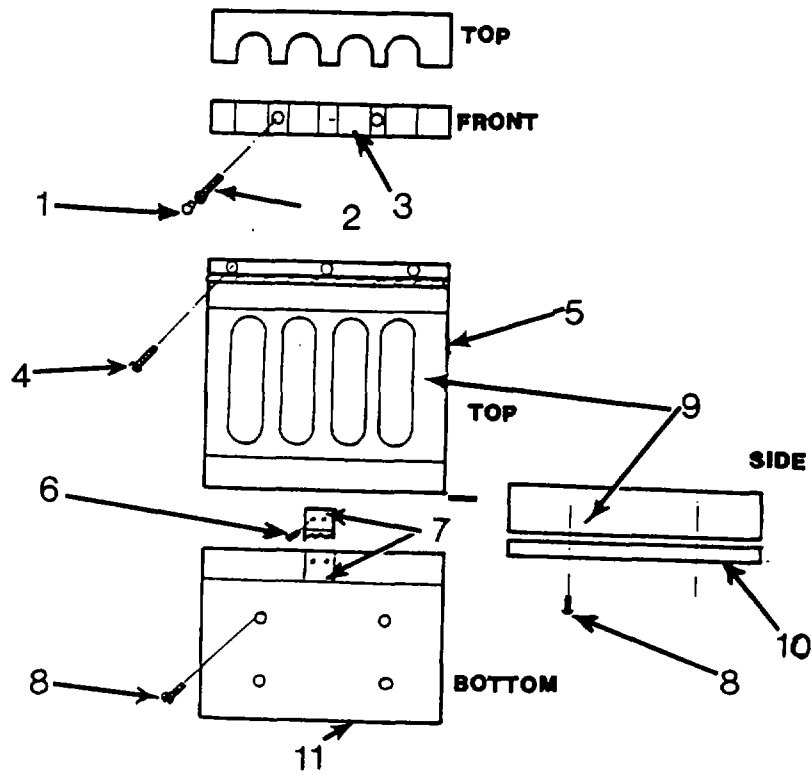

Figure 4-35. Repair Rifle Rack Assembly

4-28. RIFLE RACK ASSEMBLY. - Continued

- (2) Apply adhesive (Appendix E, item 33) to bottom of replacement rubber mat (10), and position on lower plate (11).
- (3) Secure lower rifle guide (9), rubber mat (10), and lower plate (11) with screws (8).

4-29. BLACKOUT BUZZER ASSEMBLY. Refer to Figure 4-36 for location of blackout buzzer assembly components and hardware.

This task covers: Repair

INITIAL SETUP

Tools

General Mechanics Automotive Tool Kit, Appendix B

Materials

None

WARNING

High voltage exists in the electrical system of this equipment. DEATH on contact may result if personnel fail to observe safety precautions.

a. Repair by replacing blackout switch.

- (1) Shut off ceiling light breaker (1) on power distribution panel (2).
- (2) Remove screws (3), lockwashers (4), flat washers (5), and switch plate (6).
- (3) Tag and unsolder wires (7) from blackout switch (8).
- (4) Remove nut (9) and blackout switch (8).
- (5) Position replacement blackout switch (8) and secure with nut (9).
- (6) Solder wires (7) on blackout switch (8) and remove tags.
- (7) Position switch plate (6) and secure with flat washers (5), lockwashers (4), and screws (3).

4-29. BLACKOUT BUZZER ASSEMBLY. - Continued

- (8) Turn on ceiling light circuit breaker (1) and test operation.
- b. Repair by replacing blackout buzzer.
- (1) Loosen screws (10) and remove blackout buzzer (11).
 - (2) Tag and disconnect wires (12).
 - (3) Remove screws (13), lockwashers (14), flat washers (15), and buzzer plate (16).
 - (4) Position replacement buzzer plate (16) and secure with flat washers (15), lockwashers (14), and screws (13).
 - (5) Connect wires (12) and remove tags.
 - (6) Position blackout buzzer cover (11) and tighten screws (10).

4-29. BLACKOUT BUZZER ASSEMBLY. - Continued

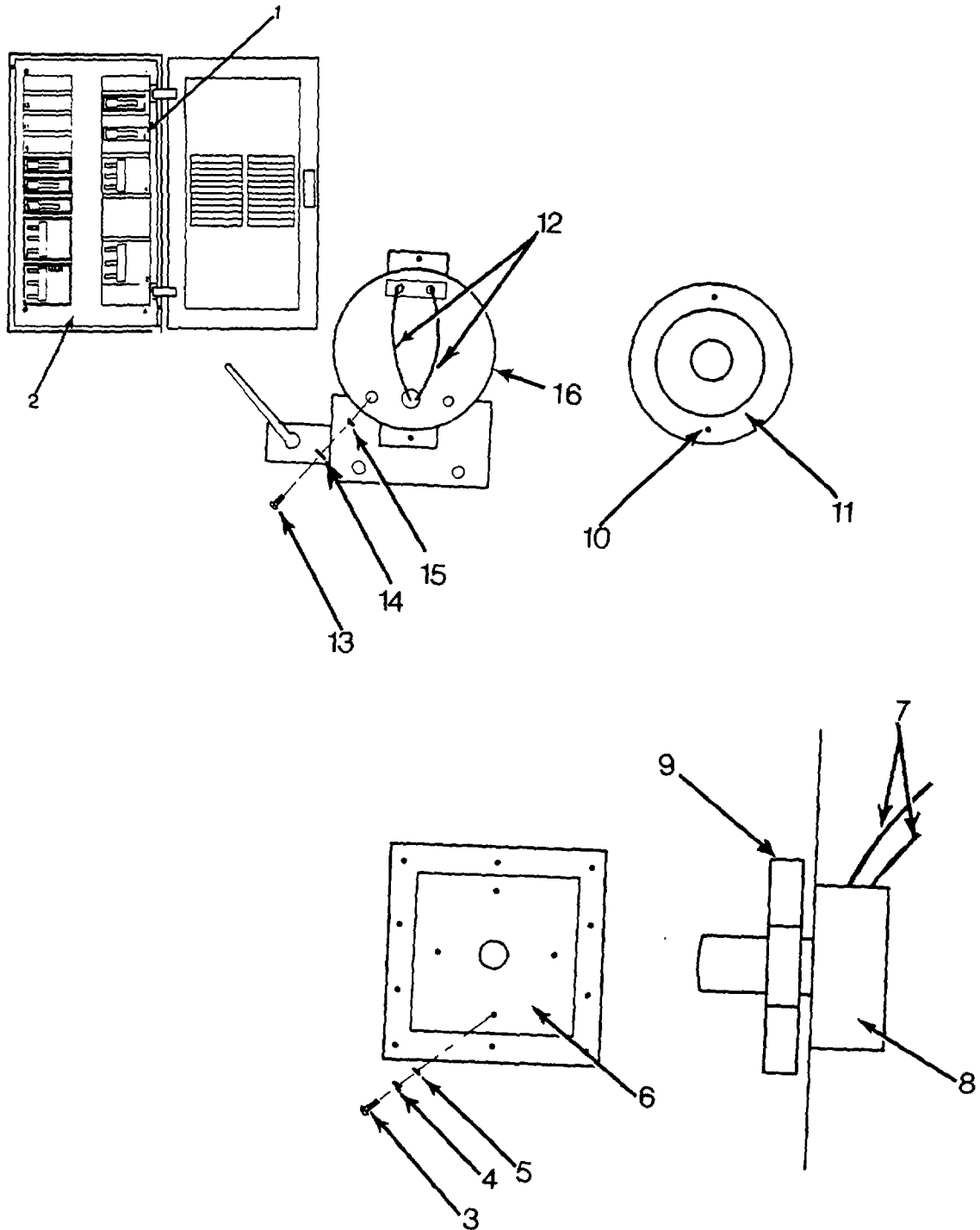

Figure 4-36. Blackout Buzzer Assembly

4-30. **EMERGENCY LIGHT.** Refer to Figure 4-37 for location of components and hardware of emergency light.

This task covers: a. Replace

b. Repair

INITIAL SETUP

Tools

Electrical Equipment Tool Kit, Appendix B
Multimeter

Materials

None

WARNING

High voltage exists in the electrical system of this equipment. **DEATH** on contact may result if personnel fail to observe safety precautions.

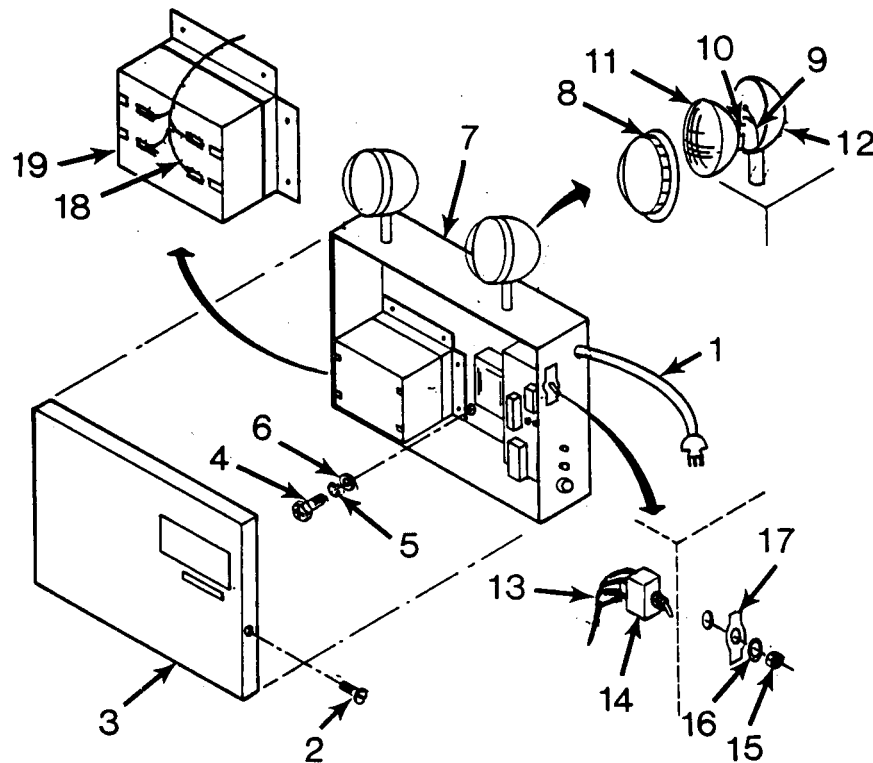

Figure 4-37. Emergency Light

4-30. EMERGENCY LIGHT. - Continued

- a. Replace
 - (1) Unplug power cord (1) from wall outlet.
 - (2) Remove screws (2) and cover (3).
 - (3) Remove screws (4), lockwashers (5), flat washers (6), and emergency light (7).
 - (4) Position replacement emergency light (7) and secure using flat washers (6), lockwashers (5), and screws (4).
 - (5) Position cover (3) and secure with screws (2).
 - (6) Plug in power cord (1), turn on power, and test operation.
- b. Repair.
 - (1) Repair by replacing sealed beam lamp.

NOTE

The following procedure is for one sealed beam lamp. The other is the same.

- (a) Unplug power cord (1) from wall outlet.
- (b) Turn retaining ring (8) counterclockwise and remove.
- (c) Tag and disconnect electrical wires (9) by loosening screws (10) and remove sealed beam lamp (11) from lamp housing (12).
- (d) Connect electrical wires (9) to replacement sealed beam lamp (11) by tightening screws (10) and remove tags.
- (e) Position replacement sealed beam lamp (11) in lamp housing (12).
- (f) Install retaining ring (8) by turning clockwise.
- (g) Plug in electrical cord (1), turn on power, and test operation by pressing TEST switch.

4-30. EMERGENCY LIGHT. - Continued

- (15).
- (2) Repair by replacing ON/OFF power switch.
 - (a) Unplug power cord (1) from wall outlet.
 - (b) Remove screws (2) and cover (3).
 - (c) Tag and unsolder wires (13) from switch (14).
 - (d) Remove nut (15), lockwasher (16), plate (17), and switch (14).
 - (e) Position replacement switch (14) and secure using plate (17), lockwasher (16), and nut
 - (f) Solder wires (13) to switch (14) and remove tags.
 - (g) Position cover (3) and secure with screws (2).
 - (h) Plug in power cord (1) and test operation.

 - (3) Repair by replacing battery
 - (a) Place ON/OFF power switch in OFF position.
 - (b) Unplug power cord (1) from wall outlet.
 - (c) Remove screws (2) and cover (3).
 - (d) Tag and disconnect electrical wires (18) from battery (19).
 - (e) Remove battery (19).
 - (f) Install replacement battery (19).
 - (g) Connect electrical wires (18) and remove tags.
 - (h) Position cover (3) and secure using screws (2).
 - (i) Plug in power cord (1), place ON/OFF power switch in ON position, and test operation.

4-31. PRINTING PRESS. The printing press is used for printing copies of documents prepared by personnel in the Press Section shelter. Refer to TM 5-3610-304-20/20P for repair procedures on the printing press.

SECTION VII. PREPARATION FOR STORAGE OR SHIPMENT

4-32. GENERAL. Refer to Chapter 2, Section III, paragraph 2-15 for detailed procedures for preparing the Press Section for storage or shipment.

CHAPTER 5. DIRECT SUPPORT MAINTENANCE INSTRUCTIONS

There are no direct support maintenance procedures for the Modular Printing System Module B.

APPENDIX A

REFERENCES

A-1. SCOPE.

This appendix lists all forms, field manuals, technical manuals and miscellaneous publications referenced in this manual.

A-2. FORMS.

Report of Packaging and Handling Deficiencies	SF-364
Quality Deficiency Report	SF-368
Recommended Changes to Publications and Blank Forms.....	DA-2028/-2

A-3. FIELD MANUALS.

Basic Cold Weather Manual	FM 31-70
Northern Operations	FM 31-71
Mountain Operations	FM 31-72

A-4. TECHNICAL MANUALS.

Destruction of Equipment to Prevent Enemy Use	TM 750-244-3
Modular Printing System, Module A	TM 5-3610-295-13&P
Modular Printing System, Module C	TM 5-3610-294-13&P
Generator Set, Diesel Engine Driven, Tactical	TM 5-6115-545-12
Shelter, Tactical, Expandable, Two-Sided	TM 10-5411-200-14/24P
Air Conditioner, Wall Mounted, Vertical 24,000	TM 5-4120-395-14&P
BTUH Cooling, 23,600 BTUH Heating	
Air Conditioner, Wall Mounted, Vertical 35,200	TM 5-4120-396-14&P
BTUH Cooling, 36,200 BTUH Heating	
Printing Press, GTOZP-52	TM 5-3610-304-10/20/20P
Complexing Kit	TM 10-5411-203-13/23P

A-5. MISCELLANEOUS PUBLICATIONS.

The Army Maintenance Management System	DA PAM 738-750
--	----------------

APPENDIX B

MAINTENANCE ALLOCATION CHART

Section I. INTRODUCTION

B-1. SCOPE.

a. This section provides a general explanation of all maintenance and repair functions authorized at various maintenance levels.

b. Section II designates overall responsibility for the performance of maintenance functions on the identified end item or component and the work measurement time required to perform the functions by the designated maintenance level. The implementation of the maintenance functions upon the end item or component will be consistent with the assigned maintenance functions.

c. Section III lists the tools and test equipment required for each maintenance function as referenced from Section II.

B-2. EXPLANATION OF COLUMNS IN SECTION II.

a. Column 1, Group Number. Column 1 lists group numbers to identify related components, assemblies, subassemblies, and modules with their next higher assembly. The applicable groups are listed in the MAC in disassembly sequence beginning with the first group removed.

b. Column 2, Component/Assembly. This column contains the noun names of components, assemblies, subassemblies and modules for which maintenance is authorized.

c. Column 3, Maintenance Functions. This column lists the functions to be performed on the item listed in Column 2. The maintenance functions are defined as follows:

(1) Inspect. To determine serviceability of an item by comparing its physical, mechanical, and/or electrical characteristics with established standards through examination.

(2) Test. To verify serviceability and detect incipient failure by measuring the mechanical or electrical characteristics of an item and comparing those characteristics with prescribed standards.

B-2. EXPLANATION OF COLUMNS IN SECTION II . - Continued

(3) Service. Operations required periodically to keep an item in proper operating condition, i.e., to clean (decontaminate), to preserve, to drain, to paint, or to replenish fuel, lubricants, hydraulic fluids, or compressed air supplies.

(4) Adjust. To maintain within prescribed limits, by bringing into proper or exact position, or by setting the operating characteristics to specified parameters.

(5) Align. To adjust specified variable elements of an item to bring about optimum or desired performance.

(6) Calibrate. To determine and cause corrections to be made or to be adjusted on instruments or test measuring and diagnostic equipments used in precision measurement. Consists of comparison of two instruments, one of which is a certified standard of known accuracy, to detect and adjust any discrepancy in the accuracy of the instrument being compared.

(7) Install. The act of emplacing, seating, or fixing into position an item, part, or module (component or assembly) in a manner to allow the proper functioning of an equipment or system.

(8) Replace. The act of substituting a serviceable like type part, subassembly, or module (component or assembly) for an unserviceable counterpart.

(9) Repair. The application of maintenance services (inspect, test, service, adjust, align, calibrate, or replace) or other maintenance actions (welding, grinding, riveting, straightening, facing, remachining, or resurfacing) to restore serviceability to an item by correcting specific damage, fault, malfunction, or failure in a part, subassembly, module (component or assembly), end item or system.

(10) Overhaul. That maintenance effort (service/action) necessary to restore an item to a completely serviceable/operational condition as prescribed by maintenance standards (i.e., DMWR) in appropriate technical publications. Overhaul is normally the highest degree of maintenance performed by the Army. Overhaul does not normally return an item to a like new condition.

(11) Rebuild. Consists of those services/actions necessary for the restoration of unserviceable equipment to a like new condition in accordance with original manufacturing standards. Rebuild is the highest degree of materiel maintenance applied to Army equipment. The rebuild operation includes the act of returning to zero those age measurements (hours/miles, etc.) considered in classifying Army equipments/components.

B-3. EXPLANATION OF COLUMNS IN SECTION III.

d. Column 4, Maintenance Category. This column is made up of subcolumns for each category of maintenance. Work time figures are listed in these subcolumns for the lowest level of maintenance authorized to perform the function listed in Column 3. These figures indicate the average active time required to perform the maintenance function at the indicated category of maintenance under typical field operating conditions.

e. Column 5, Tools and Equipment This column is provided for referencing by code, the common tool sets (not individual tools), special tools, test and support equipment required to perform the designated function.

a. Column 1, Reference Code. This column consists of an arabic number listed in sequence from Column 5 or Section II. The number references the common tool sets, special tools and test equipment requirements.

b. Column 2, Maintenance Category. This column shows the lowest category of maintenance authorized to use the special tools or test equipment.

C = OPERATOR/CREW
O = UNIT
F = DIRECT SUPPORT
H = GENERAL SUPPORT
D = DEPOT

c. Column 3, Nomenclature. This column lists the name or identification of the common tool sets, special tools or test equipment.

d. Column 4, National/NATO STOCK NUMBER (NSN). This column is provided for the NSN of common tool sets, special tools and test equipment listed in the nomenclature column.

e. Column 5, Tool Number. This column lists the manufacturer's code and part number of tools and test equipment.

B-3/(B-4 Blank)

SECTION II. MAINTENANCE ALLOCATION CHART

(1) GROUP NUMBER	(2) COMPONENT/ ASSEMBLY	(3) MAINTENANCE FUNCTION	(4) MAINTENANCE LEVEL					(5) TOOLS AND EQUIPMENT	(6) REMARKS
			UNIT		DS	GS	DEPOT		
			C	O	F	H	D		
00	Press Section Modular Printing System (Module B)								
01	Islatrol Control Box	Inspect Replace	0.1	0.5				1, 2	
02	Cargo Door Vent Assembly	Inspect Service Repair Replace	0.1 0.1	1.0 0.5				1,2, 5 1	
03	Air Conditioner Assembly	Inspect Replace	0.1	2.0				1, 2, 5	
	Mounting Bracket Assembly, Air Conditioner	Replace		4.5					
04	Ducting Assembly, Air Conditioner	Inspect Repair	0.1	0.3			*	1, 5	
05	Ceiling Light Assembly	Inspect Repair	0.1 0.2						
06	Housing Assembly, Air Conditioner	Inspect Service Repair	0.2 0.2	0.4			*	1, 5	
07	Ink Cart and Tool Caddy Assembly	Inspect Repair	0.1	1.0			*	1	
08	GTO Cabinet Assembly	Inspect Repair	0.1	0.7			*	1	
09	Storage Cabinet, Wall Mounted	Inspect Replace	0.1	0.3				1	
10	Table, Folding	Inspect Repair	0.1	1.0				1	

* Depot Repair Times to be Determined

SECTION II. MAINTENANCE ALLOCATION CHART

(1) GROUP NUMBER	(2) COMPONENT/ ASSEMBLY	(3) MAINTENANCE FUNCTION	(4) MAINTENANCE LEVEL					(5) TOOLS AND EQUIPMENT	(6) REMARKS
			UNIT		DS	GS	DEPOT		
			C	O	F	H	D		
11	Sink Assembly	Inspect Replace Repair	0.2	0.5 1.0			*1, 2, 3, 4, 5		
12	Cabinet Assembly, Paper Jogging	Inspect Repair	0.1	0.7			* 1		
13	Work Transfer Cart	Inspect Repair	0.1	0.3			* 1		
14	Complexing Kit	Replace		0.3			1	A	
15	Shelter, ISO	Replace					*	B	
16	Phase Monitor Meter	Inspect Repair	0.1	0.7			2, 3		
17	Rifle Rack Assembly	Inspect Repair	0.1	0.8			1		
18	Blackout Buzzer Assembly	Inspect Repair	0.1	0.5			2		
19	Misc Support Items	Inspect Replace	0.1	0.5			1		
20	Printing Press	Replace					* 1	C	

* Depot Repair Times to be Determined

**SECTION III TOOL AND TEST EQUIPMENT REQUIREMENTS
MODULAR PRINTING SYSTEM, EDITORIAL AND MECHANICAL SHELTER**

REFERENCE	MAINTENANCE CATEGORY	NOMENCLATURE	NATIONAL STOCK NUMBER	TOOL NUMBER
1	0	General Mechanics Automotive Tool Kit	5180-00-177-7033	SC5180-90-CL N26
2	0	Electrical Equipment Tool Kit	5180-00-876-9336	7550526 (19204)
3	0	Multimeter, Digital	6625-01-139-2512	T00377 (55026)
4	0	Wrench, Pipe	5120-01-192-9385	PW18B (55719)
5	0	Hand Blind Riveter	5120-00-017-2849	98 (61957)

SECTION IV. REMARKS

REFERENCE CODE	REMARKS
A	Consult TM 10-5411-203-13/23P for maintenance instructions and repair parts for the Complexing Kit .
B	Consult TM 10-5411-200-14 for maintenance instructions and repair parts for the two-sided expandable ISO shelter .
C	Consult TM 5-3610-304-10 , TM 5-3610-304-20 and TM 5-3610-304-20P for maintenance instructions and repair parts for the Printing Press .

APPENDIX C

COMPONENTS OF END ITEM AND BASIC ISSUE ITEMS LIST

SECTION I. INTRODUCTION

C-1. SCOPE

This appendix lists components of end item and basic issue items for the Press Section to help you inventory items required for safe and efficient operation.

C-2. GENERAL

The Components of End Item and Basic Issue Items List is provided in Section II. This listing is for informational purposes only, and is not authority to requisition replacements. These items are part of the end item, but are removed and separately packaged for transportation or shipment. As part of the end item, these items must be with the end item whenever it is issued or transferred between property accounts. Illustrations are furnished to assist you in identifying the items.

C-3. EXPLANATION OF COLUMNS IN SECTION II

The following provides an explanation of columns found in the tabular listings:

- a. Column (1) - Illustration Number (Illus Number). This column indicates the number of the illustration in which the item is shown.
- b. Column (2) - National Stock Number. Indicates the National Stock Number assigned to the item and will be used for requisitioning purposes.
- c. Column (3) - Description. Indicates the Federal item name and, if required, a minimum description to identify and locate the item. The last line for each item indicates the CAGE (in parentheses) followed by the part number.
- d. Column (4) - Unit of Measure (U/M). Indicates the measure used in performing the actual operational/maintenance function. This measure is expressed by a two-character alphabetical abbreviation (e.g., ea, in, pr).
- e. Column (5) - Quantity required (Qty rqr). Indicates the quantity of the item authorized to be used with/on the equipment.

C-1/(C-2 Blank)

Section II. COMPONENTS OF END ITEM

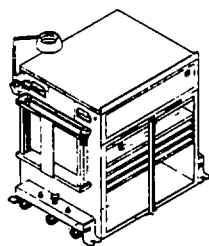

1

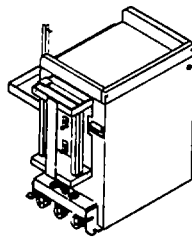

2

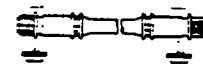

3



4



5



6



7

(1) ILLUS NUMBER	(2) NATIONAL STOCK NUMBER	(3) DESCRIPTION CAGEC AND PART NUMBER	USABLE ON CODE	(4) U/M	(5) QTY RQD
1	Not Assigned	CABINET, G.T.O. (81337) 5-13-4826		EA	1
2	Not Assigned	CABINET, PAPER JOGGING (81337) 5-13-4828		EA	1
3	Not Assigned	CABLE ASSEMBLY, POWER, 75 ft., (81337) 5-13-4791		EA	1
4	7240-00-240-6958	CAN, SAFETY, 5 GL		EA	1
5	7240-00-139-7521	CAN, WASTE, 44 GL		EA	1
6	7240-00-244-7412	CAN, SAFETY, 1 QT		EA	2
7	7240-00-282-8411	CAN, FLAMMABLE WASTE, 6 GL		EA	1

SECTION II. COMPONENTS OF END ITEM

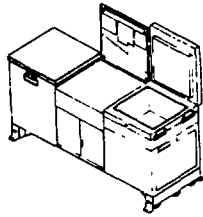

8



9

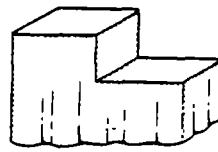

10

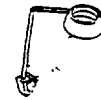

11

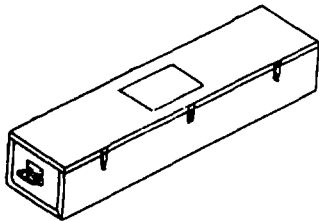

12



13

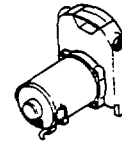

14

(1) ILLUS NUMBER	(2) NATIONAL STOCK NUMBER	(3) DESCRIPTION CAGEC AND PART NUMBER	USABLE ON CODE	(4) U/M	(5) QTY RQD
8	Not Assigned	CART, INK (81337) 5-13-4740		EA	1
9	Not Assigned	CART, WORK TRANSFER (84570) 1925-T		EA	1
10	Not Assigned	COVER, PRINTING PRESS (81337) 5-13-5060		EA	1
11	6650-00-477-9613	LAMP, MAGNIFIER		EA	1
12	8340-01-277-0618	KIT, SPARE PARTS, PASSAGEWAY		EA	1
13	7220-01-057-1897	MATTING, FLOOR		YD	2
14	Not Assigned	PUMP, PORTABLE (15883) PC4		EA	1

SECTION II. COMPONENTS OF END ITEM



15



16

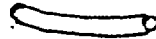

17

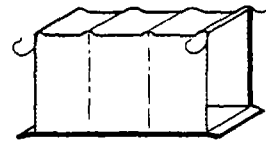

18

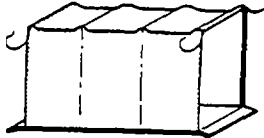

19



20

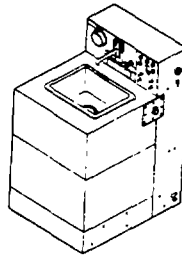

21



22

(1) ILLUS NUMBER	(2) NATIONAL STOCK NUMBER	(3) DESCRIPTION CAGE AND PART NUMBER	USABLE ON CODE	(4) U/M	(5) QTY RQD
15	4720-00-202-6483	HOSE, DRAIN, 25 FT.		EA	1
16	4720-00-202-6722	HOSE, ASSEMBLY, 50 FT.		EA	1
17	2720-01-297-6487	HOSE, CLEAR, 1/2 IN.		FT	2
18	8340-01-277-0619	PASSAGEWAY, TENT; DESERT TAN		EA	1
19	8340-01-277-0620	PASSAGEWAY, TENT; FOREST GREEN		EA	1
20	5975-00-878-3971	ROD, GROUND, COPPER		EA	1
21	Not Assigned	SINK ASSEMBLY (81337) 5-13-4942		EA	1
22	5120-01-013-1676	SLIDE HAMMER, GROUND ROD		EA	1

SECTION II. COMPONENTS OF END ITEM

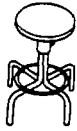

23



24

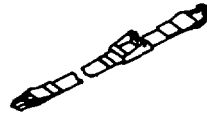

25

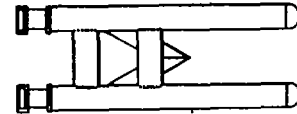

26



27



28



29

(1) ILLUS NUMBER	(2) NATIONAL STOCK NUMBER	(3) DESCRIPTION CAGE AND PART NUMBER	USABLE ON CODE	(4) U/M	(5) QTY RQD
23	7110-00-634-3516	STOOL, REVOLVING	EA	2	
24	7105-00-782-3166	STOOL, STEP	EA	1	
25	5340-01-225-8669	STRAP, TIEDOWN, PASSAGEWAY	EA	4	
26	Not Assigned	STRAP, WEBBING, DOUBLE (97403) 13227E5821	EA	2	
27	Not Assigned	STRAP, TIEDOWN, RUBBER (39428) 3891T18	EA	10	
28	Not Assigned	DUCT, FLEXIBLE, AIR CONDITIONER (39428) 5266K59	FT	3	
29	Not Assigned	GRABBER, PAPER (65713) 36-024-065	EA	1	

SECTION II. COMPONENTS OF END ITEM



30



31



32



33



34

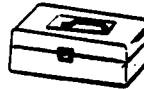

35



36

(1) ILLUS NUMBER	(2) NATIONAL STOCK NUMBER	(3) DESCRIPTION CAGE AND PART NUMBER	USABLE ON CODE	(4) U/M	(5) QTY RQD
30	5120-00-928-4191	WRENCH, HEX, 5/16 IN., T-HANDLE		EA	1
31	5120-00-106-7598	JACK SCISSOR, 2 TON		EA	4
32	Not Assigned	HANDLE, JACK (Part of Jack)		EA	2
33	4510-01-254-1044	EYEWASH UNIT		EA	1
34	Not Assigned	PUNCH, PLATE (81337) 5-13-4965		EA	1
35	5140-00-331-5496	BOX, TOOL (OPERATOR)		EA	1
36	5120-00-230-6385	WRENCH, RATCHET, 1/2 IN DRIVE, (SOLAR BAR)		EA	1

SECTION III. BASIC ISSUE ITEMS

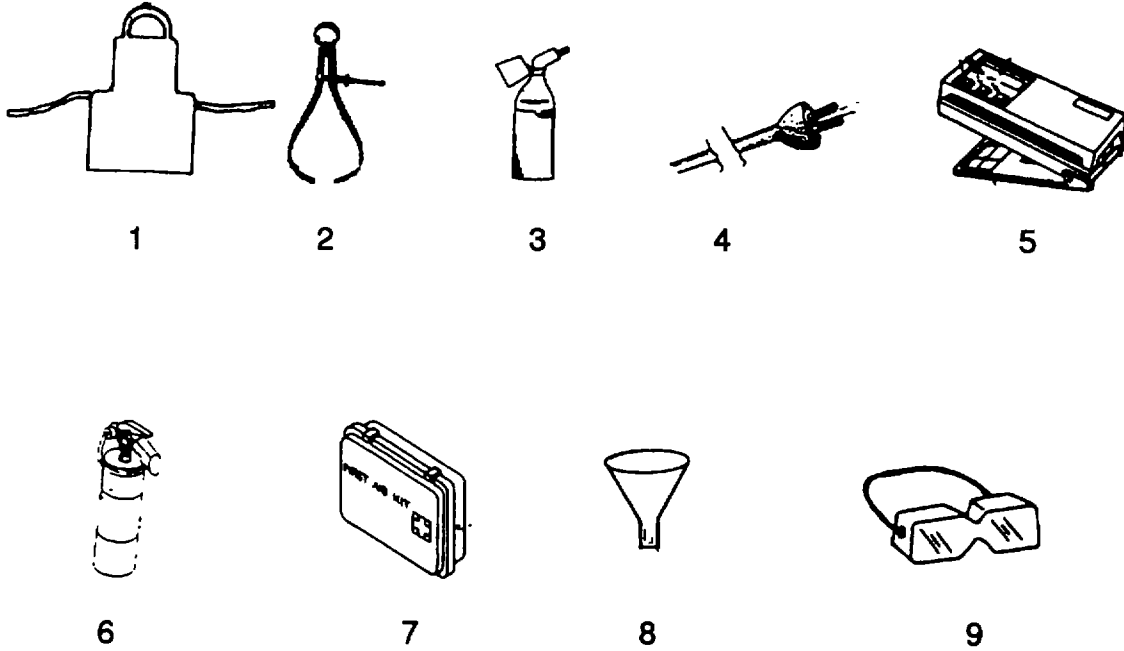

(1) ILLUS NUMBER	(2) NATIONAL STOCK NUMBER	(3) DESCRIPTION CAGE AND PART NUMBER	USABLE ON CODE	(4) U/M	(5) QTY RQD
1	8415-00-257-4290	APRON, CLOTH		EA	2
2	5210-00-223-9159	CALIPER, MICROMETER		EA	1
3	4930-00-266-9182	CAN OIL		EA	1
4	6230-00-485-6149	CORD, ELECTRICAL, 25 FT.		EA	1
5	Not Assigned	DENSITOMETER (56573) 4005B		EA	1
6	4210-00-165-4703	EXTINGUISHER, FIRE		EA	2
7	6545-00-922-1200	FIRST AID KIT		EA	1
8	3610-00-843-5818	FUNNEL STEEL		EA	1
9	4240-00-052-3776	GOGGLES, INDUSTRIAL		EA	2

SECTION III. BASIC ISSUE ITEMS

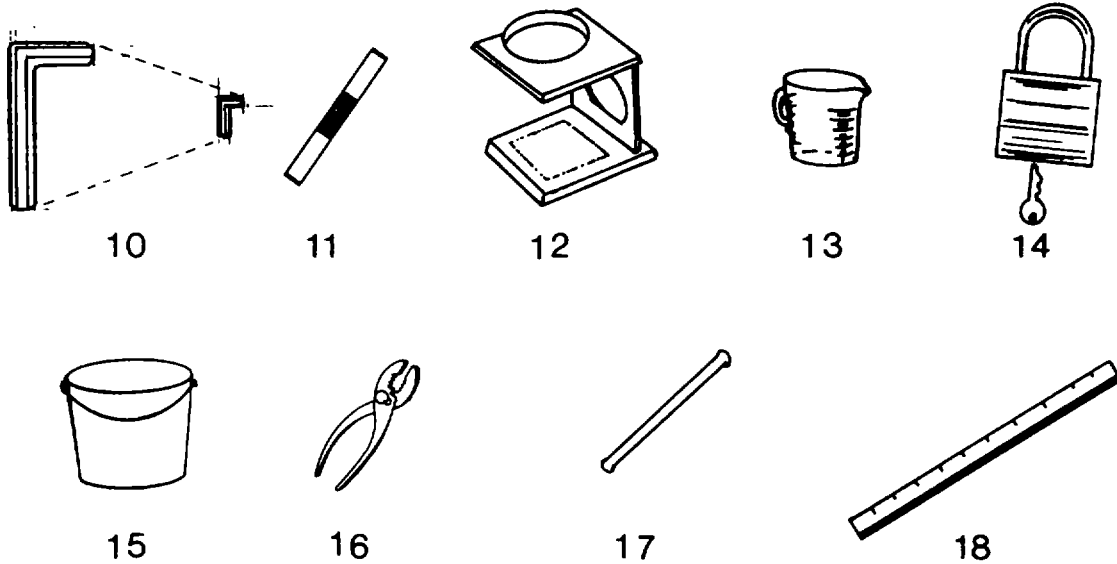

(1) ILLUS NUMBER	(2) NATIONAL STOCK NUMBER	(3) DESCRIPTION CAGEC AND PART NUMBER	USABLE ON CODE	(4) U/M	(5) QTY RQD
10	5120-00-595-9244	KEY SET, HEX, 11 PC		EA	1
11	Not Assigned	LEVEL, HAND, SURVEYING (7D560) 37567		EA	1
12	6650-00-255-8268	LINEN TESTER		EA	1
13	7240-00-889-3765	MEASURE, GRADUATED		EA	1
14	5340-00-682-1505	PADLOCK SET		EA	1
15	7240-00-137-1608	PAIL, UTILITY, PLASTIC		EA	1
16	5120-00-223-7396	PLIERS, SLIP-JOINT, 6 IN.		EA	1
17	3610-00-843-5797	ROD, STIRRING		EA	2
18	Not Assigned	RULER, 20 IN. (39428) 1970A71		EA	1

*U.S. GOVERNMENT PRINTING OFFICE: 1994 - 655-028/00442

SECTION III. BASIC ISSUE ITEMS



19



20

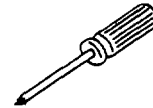

21

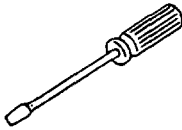

22

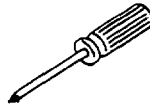

23

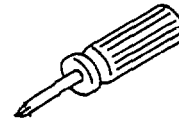

24

(1) ILLUS NUMBER	(2) NATIONAL STOCK NUMBER	(3) DESCRIPTION CAGEC AND PART NUMBER	USABLE ON CODE	(4) U/M	(5) QTY RQD
19	5120-00-764-8080	SCREWDRIVER, CROSS-TIP, #1		EA	1
20	5120-00-240-8716	SCREWDRIVER, CROSS-TIP, #1		EA	1
21	5120-00-764-8102	SCREWDRIVER, CROSS-TIP, #3		EA	1
22	5120-00-240-8910	SCREWDRIVER, FLAT-TIP, 5/16 IN.		EA	1
23	5120-00-596-0861	SCREWDRIVER, CROSS-TIP, #2		EA	1
24	5120-00-227-7293	SCREWDRIVER, CROSS-TIP, #2 STUBBY		EA	1

SECTION III. BASIC ISSUE ITEMS

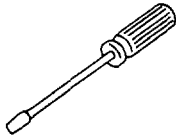

25



26

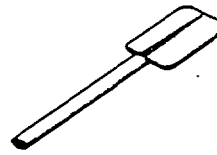

27

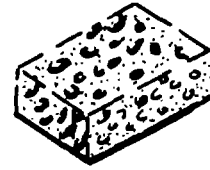

28



29

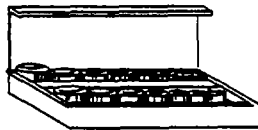

30

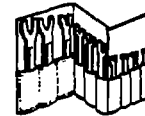

31

(1) ILLUS NUMBER	(2) NATIONAL STOCK NUMBER	(3) DESCRIPTION CAGE AND PART NUMBER	USABLE ON CODE	(4) U/M	(5) QTY RQD
25	5120-00-596-8502	SCREWDRIVER, FLAT-TIP, 1/4 IN.		EA	1
26	5110-00-162-2207	SHEAR, STRAIGHT TRIMMERS, 12 IN.		EA	1
27	6640-00-439-7350	SPATULA		EA	2
28	7920-00-240-2555	SPONGE		EA	5
29	5120-00-240-5328	WRENCH, ADJUSTABLE, 8"		EA	1
30	5120-00-081-2305	WRENCH SET, SOCKET 1/4 IN. DRIVE		EA	1
31	5120-00-148-7918	WRENCH SET, COMBINATION		EA	1

APPENDIX D

ADDITIONAL AUTHORIZED LIST ITEMS

Section I. INTRODUCTION

D-1. SCOPE.

This appendix lists additional items you are authorized for the support of the Press Section.

D-2. GENERAL.

This list identifies items that do not have to accompany the Press Section and that do not have to be turned in with it. These items are all authorized to you by CTA, MTOE, TDA, or JTA.

D-3. EXPLANATION OF LISTING.

National stock numbers, descriptions, and quantities are provided to help you identify and request the additional items you require to support this equipment. The items are listed in alphabetical sequence by item name under the type document (i.e., CTA, MTOE, TDA, or JTA) which authorizes the item(s) to you.

Section II. ADDITIONAL AUTHORIZATION LIST

NSN	DESCRIPTION	QTY
2330-01-167-7262	Dolly Set, 7 1/2 ton	1 EA
2330-01-230-0308	TRUCK, CARGO; 5 ton	1 EA

APPENDIX E
EXPENDABLE/DURABLE SUPPLIES AND MATERIALS LIST

Section I. INTRODUCTION

E-1. SCOPE

Section II of this appendix lists expendable supplies and materials you will need to operate and maintain the Press Section. These items are authorized to you by CTA 50-950, Expendable Items.

E-2. EXPLANATION OF COLUMNS IN SECTION II

a. Column 1, Item Number. This number is assigned to the entry and is referenced in the narrative instructions to identify the material.

b. Column 2, Level. This column identifies the lowest level of maintenance that requires the listed item.

C - Operator/Crew
O - Unit Maintenance

c. Column 3, National Stock Number. This is the National stock number assigned to the item; use it to request or requisition the item.

d. Column 4, Description. Indicates the Federal item name and, if required, a description to identify the item. The last line for each item indicates the Contractor and Government Entity (CAGE) in parenthesis followed by the part number.

e. Column 5, Unit of Measure (U/M). Indicates the measure used in performing the actual maintenance function. This measure is expressed by a two character alphabetical abbreviation (e.g., ea, in, pr). If the unit of measure differs from the unit of issue, requisition the lowest unit of issue that will satisfy your requirements.

E-1/(E-2 Blank)

SECTION II. EXPENDABLE / DURABLE SUPPLIES AND MATERIAL LIST

(1) ITEM NUMBER	(2) CATEGORY	(3) NATIONAL STOCK NUMBER	(4) DESCRIPTION	(5) U/M
01	C	8530-00-162-5627	BLADE, RAZOR	PK
02	C	8305-00-205-3496	CHEESECLOTH: Bleached	PK
03	C	Not Assigned	CLEANER, ROLLER: Van Son Holland Ink Corp. (55269) V2082	EA
04	C	6850-01-123-8892	CLEANER/CONDITIONER: Lithographic plate, 3M Co. (52942) Cat No. 77-9800-7222-5	QT
05	C	8520-00-527-9942	CLEANER, HAND: Type 1, Class 1, DGSC, P-H-31	PT
06	C	4130-00-860-0042	COATER: Air Conditioner Filter (80009) 006-0580-00	EA
07	C	8320-00-299-8625	COTTON: Nonsterile	PK
08	C	8140-00-248-3228	GLOVES: Disposable, polyurethane, 100/box (12901) 1R100	BX
09	C	Not Assigned	GUM: Clear subtractive (52942) Cat. No. 77-9801-6645-6 INK: Lithographic process, oil base, 5 lb. can, colors as follows: (55269)	QT
10	C	Not Assigned	Yellow, VS-751	CN
11	C	Not Assigned	Warm Red, VS-752	CN
12	C	Not Assigned	Rubine Red, VS-753	CN
13	C	Not Assigned	Rhodrmine Red, VS-754	CN

SECTION II. EXPENDABLE / DURABLE SUPPLIES AND MATERIAL LIST

(1) ITEM NUMBER	(2) CATEGORY	(3) NATIONAL STOCK NUMBER	(4) DESCRIPTION	(5) U/M
14	C	Not Assigned	Purple, VS-755	CN
15	C	Not Assigned	Retlex Blue, VS-756	CN
16	C	Not Assigned	Process Blue, VS-757	CN
17	C	Not Assigned	Green, VS-758	CN
18	C	Not Assigned	White, VS-759	CN
19	C	Not Assigned	Black, VS-760	CN
20	C	6850-00-746-6999	LITHOGRAPHIC BLANKET: Roller wash (00494) O-L-298	EA
21	C	Not Assigned	LITHOGRAPHIC FOUNTAIN CONCENTRATE (52942) Cat. No. 77-9800-7214-4	GL
22	C	6580-00-050-0659	LUBRICANT: Corrosion Protectant	CN
23	C	9150-00-252-6173	LUBRICATING OIL: General purpose (light), 4 oz. can VVL-820	CN
24	C	Not Assigned	PAPER: Packing Mark 3 set for use with Heidelberg GTOZP Printing Press (62657) 0.002 in. thick, salmon 0.006 in. thick, brown 0.010 in. thick, golden 0.012 in. thick, lemon 0.016 in. thick, blue	PK PK PK PK PK

SECTION II. EXPENDABLE / DURABLE SUPPLIES AND MATERIAL LIST

(1) ITEM NUMBER	(2) CATEGORY	(3) NATIONAL STOCK NUMBER	(4) DESCRIPTION	(5) U/M
25	C	Not Assigned	PH TESTER (55269) V2052	EA
26	C	5350-00-161-9034	PUMICE: Technical Pulverized, 5 lb. can	CN
27	C	3610-00-843-5369	REJUVENATOR: Blanket (23953) NY121	GL
28	C	Not Assigned	SCRATCH REMOVER: Lithographic bottle plate for use with 3M Niking offset plates (52942) Cat. no. 77-9801-0712-0	EA
29	C	7920-00-240-2555	SPONGE: Cellulose	EA
30	C	Not Assigned	SPRAY: Anti-skin, 16 oz. size, (55269) V2001	EA
31	C	8540-00-262-7179	TOWEL: Paper, single fold, 250 per pack	PK
32	C	Not Assigned	VARNISH: Lithographic (55269) V2159	CN
33	O	8040-00-865-8991	ADHESIVE/SEALANT: Silicone RTV, General Purpose, Black, 12 oz. cartridge	CN
34	O	8040-00-255-4548	ADHESIVE/SEALANT: Silicone RTV, General Purpose, White, 12 oz. cartridge	CN
35	O	6505-00-153-8809	LUBRICANT, SURGICAL	TB
36	O	8030-00-889-3535	TAPE, THREAD SEAL, ANTI- SEIZING; 1/2 x 610 inch roll	EA

**APPENDIX F
UNIT AND DIRECT SUPPORT MAINTENANCE
(INCLUDING DEPOT MAINTENANCE)
REPAIR PARTS AND SPECIAL TOOLS LIST**

SECTION I. INTRODUCTION

1. SCOPE. This RPSTL lists and authorizes spares and repair parts; special tools; special test, measurement, and diagnostic equipment (TMDE); and other special support equipment required for performance of Unit and Direct Support maintenance of the Press Section. It authorizes the requisitioning, issue, and disposition of spares, repair parts and special tools as indicated by the source, maintenance and recoverability (SMR) codes.

2. GENERAL. In addition to this section, Introduction, this Repair Parts and Special Tools List is divided into the following sections:

- a. Section II. Repair Parts List.** A list of spares and repair parts authorized by this RPSTL for use in the performance of maintenance. The list also includes parts which must be removed for replacement of the authorized parts. Parts lists are composed of functional groups in ascending alphanumeric sequence, with the parts in each group listed in ascending figure and item number sequence. Bulk materials are listed in item name sequence. Repair parts kits are listed separately in their own functional group within Section II. Repair parts for repairable special tools are also listed in this section. Items listed are shown on the associated illustration(s)/figure(s).
- b. Section III. Special Tools List.** A list of special tools, special TMDE, and other special support equipment authorized by this RPSTL (as indicated by Basis of Issue (BOI) information in DESCRIPTION AND USABLE ON CODE column) for the performance of maintenance.
- c. Section IV. Cross-references Indexes.** A list, in National Item Identification Number (NIIN) sequence, of all National stock numbered items appearing in the listing, followed by a list in alphanumeric sequence of all part numbers appearing in the listings. National stock numbers and part numbers are cross referenced to each illustration figure and item number appearance. The figure and item number index lists figure and item number in alphanumeric sequence and cross references NSN, CAGEC and part number.

3. EXPLANATION OF COLUMNS (SECTIONS II AND III).

- a. ITEM NO. (Column (1)).** Indicates the number used to identify items called out in the illustration.
- b. SMR Code (Column (2)).** The Source, Maintenance, and Recoverability (SMR) code is a 5-position code containing supply/requisitioning information, maintenance category authorization criteria, and disposition instruction, as shown in the following breakout:

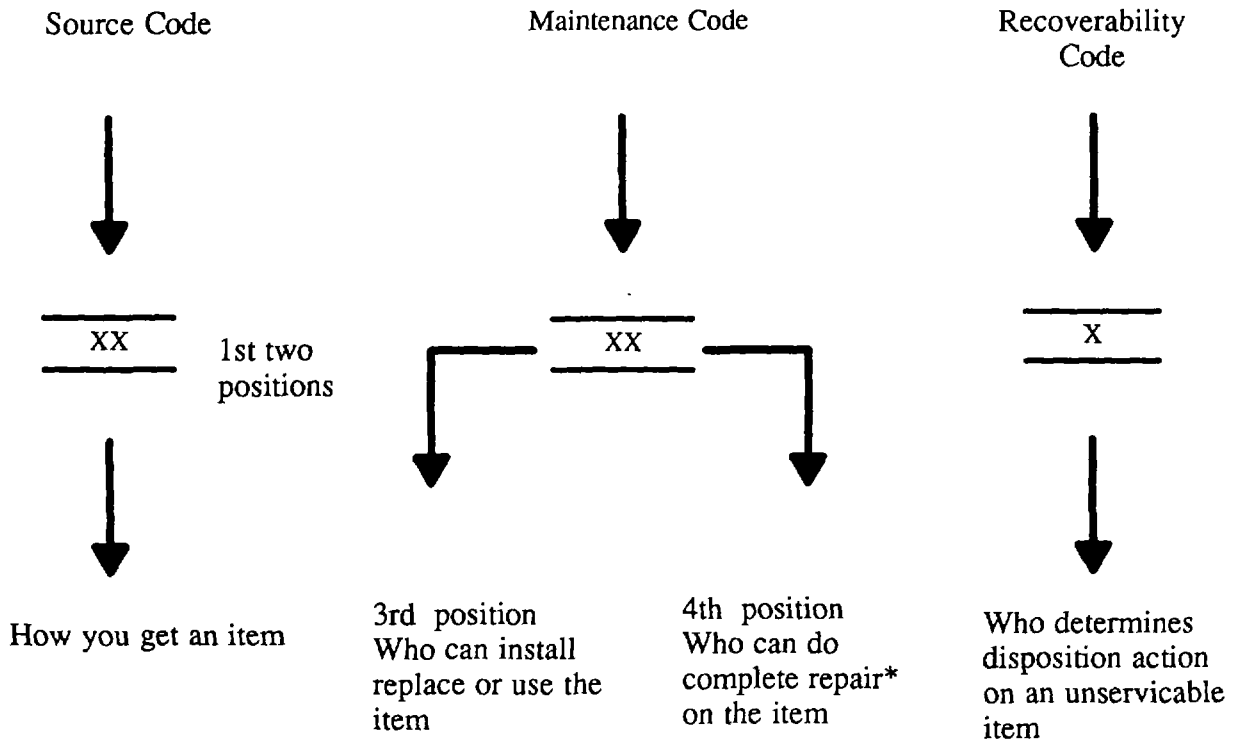

*Complete Repair: Maintenance capacity, capability, and authority to perform all corrective maintenance tasks of the "Repair" function in a use/user environment in order to restore serviceability to a failed item.

- (1) **Source Code.** The source code tells you how to get an item needed for maintenance, repair, or overhaul of an end item/equipment. Explanations of source codes follows:

Code	Explanation
PA PB PC** PD PE PF PG	<p>Stocked items; use the applicable NSN to request/requisition items with these source codes. They are authorized to the category indicated by the code entered in the 3rd position of the SMR code.</p> <p>**NOTE : Items coded PC are subject to deterioration.</p>

KD KF KB	<p>Items with these codes are not to be requested/requisitioned individually. They are part of a kit which is authorized to the maintenance category indicated in the 3rd position of the SMR code. The complete kit must be requisitioned and applied.</p>
----------------	---

Code	Explanation
MO (Made at org AVUM level) MF (Made at DS/AVUM level) MH (Made at GS level) ML (Made at Specialized Repair Activity (SRA)) MD (Made at Depot)	<p>Items with these codes are not to be requested/requisitioned individually. They must be made from bulk material which is identified by the part number in the DESCRIPTION and USABLE ON CODE (UOC) column and listed in the Bulk Material group of the repair parts list in the RPSTL. If the item is authorized to you by the 3rd position code of the SMR code, but the source code indicates it is made at a higher level, order the item from the higher level of maintenance.</p>

Code	Explanation
AO (Assembled by org AVUM Level) AF (Assembled by DS/AVUM Level) AH (Assembled by GS Category) AL (Assembled by SRA) AD (Assembled by Depot)	<p>Items with these codes are not to be requested/requisitioned individually. The parts that make up the assembled item must be requisitioned or fabricated and assembled at the level of maintenance indicated by the source code. If the 3rd position code of the SMR code, authorizes you to replace the item, but the source code indicates the items are assembled at a higher level, order the item from the higher level of maintenance.</p>

- | Code | Explanation |
|------|---|
| XA | - - Do not requisition an "XA"-coded item. Order its next higher assembly. (Also, refer to the NOTE below.) |
| XB | - - If an "XB" item is not available from salvage, order it using the CAGE Code and part number given. |
| XC | - -Installation drawing, diagram, instruction sheet, field service drawing, that is identified by manufacturer's part number. |
| XD | - - Item is not stocked. Order an "XD"-coded item through normal supply channels using the CAGE Code and part number given, if no NSN is available. |

NOTE

Cannibalization or controlled exchange, when authorized, may be used as a source of supply for items with the above source codes, except for those source coded "XA" or those aircraft support items restricted by requirements of AR 750-1

(2) Maintenance Code. Maintenance codes tell you the level(s) of maintenance authorized to USE and REPAIR support items. The maintenance codes are entered in the third and fourth positions of the SMR code as follows:

(a) The maintenance code entered in the third position tells you the lowest maintenance level authorized to remove, replace, and use an item. The maintenance code entered in the third position will indicate authorization to the following levels of maintenance.

Code	Application/Explanation
C	Crew or operator maintenance done within organizational or aviation unit maintenance.
O	Organizational or aviation unit category can remove, replace, and use the item.
F	Direct support or aviation intermediate level can remove, replace, and use the item.
H	General support level can remove, replace, and use the item.
L	Specialized repair activity can remove, replace, and use the item.
D	Depot level can remove, replace, and use the item.

(b) The maintenance code entered in the fourth position tells whether or not the item is to be repaired and identifies the lowest maintenance level with the capability to do complete repair (i.e., perform all authorized repair functions). This position will contain one of the following maintenance codes. NOTE: Some limited repair may be done on an item at a lower level of maintenance, if authorized by the Maintenance Allocation Chart (MAC) and SMR codes.

Code	Application/Explanation
O	Organizational or (aviation unit) is the lowest level that can do complete repair of the item.
F	Direct support or aviation intermediate is the lowest level that can do complete repair of the item.
H	General Support is the lowest level that can do complete repair of the item.

L - Specialized repair activity is the lowest level that can do complete repair of the item.

D - Depot is the lowest level that can do complete repair of the item.

Z - Nonreparable. No repair is authorized.

B - No repair is authorized. No parts or special tools are authorized for the maintenance of a "B" coded item. However, the item may be reconditioned by adjusting, lubricating, etc., at the user level.

(3) Recoverability. Recoverability codes are assigned to items to indicate the disposition action on unserviceable items. The recoverability code is entered in the fifth position of the SMR Code as follows:

Recoverability Codes	Application/Explanation
Z -	Nonreparable item. When unserviceable, condemn and dispose of the item at the level of maintenance shown in 3rd position of SMR Code.
O -	Reparable item. When not economically repairable, condemn and dispose of the item at organizational or aviation unit level.
F -	Reparable item. When uneconomically repairable, condemn and dispose of the item at the direct support or aviation intermediate level.
H -	Reparable item. When uneconomically repairable, condemn and dispose of the item at the general support level.
D -	Reparable item. When beyond lower level repair capability, return to depot. Condemnation and disposal of item not authorized below depot level.
L -	Reparable item. Condemnation and disposal not authorized below specialized repair activity (SRA).
A -	Item requires special handling or condemnation procedures because of specific reasons (e.g., precious metal content, high dollar value, critical material, or hazardous material). Refer to appropriate manuals/directives for specific instructions.

c. CAGEC (Column (3)). The Commercial and Government Entity Code (CAGEC) is a 5-digit numeric code which is used to identify the manufacturer, distributor, or Government agency/activity that supplies the item.

d. PART NUMBER (Column (4)). Indicates the primary number used by the manufacturer, (individual, company, firm, corporation, or Government activity), which controls the design and characteristics of the item by means of its engineering drawings, specifications, standards, and inspection requirements to identify an item or range of items.

NOTE

When you use an NSN to requisition an item, the item you receive may have a different part number from the number listed.

- e. DESCRIPTION AND USABLE ON CODE (UOC) (Column (5)).** This column includes the following information:
- (1) The Federal item name and, when required, a minimum description to identify the item.
 - (2) The physical security classification of the item is indicated by the parenthetical entry, e.g., Phy Sec C1 (C)-Confidential, Phy Sec C1 (S)-Secret, Phy Sec C1 (T)-Top-Secret.
 - (3) Items that are included in kits and sets are listed below the name of the kit or set.
 - (4) Spare/repair parts that make up an assembled item are listed immediately following the assembled item line entry.
 - (5) Part numbers of bulk materials are referenced in this column in the line entry for the item to be manufactured/fabricated.
 - (6) When the item is not used with all serial numbers of the same model, the effective serial numbers are shown on the last line(s) of the description (before UOC).
 - (7) The usable on code, when applicable (reference paragraph 5, Special Information).
 - (8) In the Special Tools List Section, the basis of issue (BOI) appears as the last line(s) in the entry for each special tool, special TMDE, and other special support equipment. When density of equipment supported exceeds density spread indicated in the basis of issue, the total authorization is increased proportionately.
 - (9) The statement "END OF FIGURE" appears just below the last item description in Column (5) for a given figure in both Section II and Section III.
 - (10) The indenture, shown as dots appearing before the repair part, indicates that the item is a repair part of the next higher assembly.

f. QTY (Column (6)). The QTY (quantity per figure) column indicates the quantity of the item used in the breakout shown on the illustration/figure, which is prepared for a functional group, subfunctional group, or an assembly. A "V" appearing in this column instead of a quantity indicates that the quantity is variable and may vary from application to application.

4. EXPLANATION OF INDEX FORMAT AND COLUMNS (SECTION IV).

a. NATIONAL STOCK NUMBER (NSN) INDEX.

(1) **STOCK NUMBER Column.** This column lists the NSN in national item identification number (NIIN) sequence. The NIIN consists of the last nine digits of the NSN, i.e.

NSN
 5305-01-574-1467
NIIN

When using this column to locate an item, ignore the first four digits of the NSN. Use the complete NSN when requisitioning items by stock number.

- (2) **FIG. Column.** This column lists the number of the figure where the item is identified/located. The figures are in numerical order in Section II and Section III.
 - (3) **ITEM Column.** The item number identifies the item associated with the figure listed in the adjacent FIG. column. This item is also identified by the NSN listed on the same line.
- b. PART NUMBER INDEX.** Part numbers in this index are listed in ascending alphanumeric sequence (i. e., vertical arrangement of letter and number combinations which place the first letter or digit of each group in order A through Z, followed by the numbers 0 through 9, and each following letter or digit in like order).
- (1) **CAGEC Column.** The Commercial and Government Entity Code (CAGEC) is a 5-digit numeric code used to identify the manufacturer, distributor, or Government agency/activity that supplies the item.
 - (2) **PART NUMBER Column.** Indicates the primary number used by the manufacturer (individual, firm, corporation, or Government activity), which controls the design and characteristics of the item by means of its engineering drawings, specifications, standards, and inspection requirements to identify an item or range of items.
 - (3) **STOCK NUMBER Column.** This column lists the NSN for the associated part number and manufacturer identified in the PART NUMBER and CAGEC columns to the left.
 - (4) **FIG. Column.** This column lists the number of the figure where the item is identified/located in Section II and Section III.
 - (5) **ITEM Column.** The item number is that number assigned to the item as it appears in the figure referenced in the adjacent figure number column.

c. FIGURE AND ITEM NUMBER INDEX.

- (1) **FIG. Column.** This column lists the number of the figure where the item is identified/located in Section II and Section III.
- (2) **ITEM Column.** The item number is that number assigned to the item as it appears in the figure referenced in the adjacent figure number column.
- (3) **STOCK NUMBER Column.** This column lists the NSN for the item.
- (4) **CAGEC Column.** The Commercial and Government Entity Code (CAGEC) is a 5-digit numeric code used to identify the manufacturer, distributor, or Government agency/activity that supplies the item.
- (5) **PART NUMBER Column.** Indicates the primary number used by the manufacturer (individual, firm, corporation, or Government activity), which controls the design and characteristics of the item by means of its engineering drawings, specifications, standards, and inspection requirements to identify an item or range of items.

5. SPECIAL INFORMATION.

- a. **USABLE ON CODE.** The usable on code appears in the lower left corner of the Description column heading. Usable on codes are shown as "UOC:.." in the Description Column justified left) on the last line of the applicable item description/nomenclature. Uncoded items are applicable to all models.
- b. **ASSOCIATED PUBLICATIONS.** Refer to Appendix A, References.

6. HOW TO LOCATE REPAIR PARTS.

a. **When National Stock Number or Part Number is NOT Known.**

- (1) **First.** Using the table of contents, determine the assembly group or subassembly group to which the item belongs. This is necessary since figures are prepared for assembly groups and subassembly groups, and listings are divided into the same groups.
- (2) **Second.** Find the figure covering the assembly group or subassembly group to which the item belongs.
- (3) **Third.** Identify the item on the figure and note the item number.
- (4) **Fourth.** Refer to the Repair Parts List for the figure to find the part number for the item number noted on the figure.
- (5) **Fifth.** Refer to the Part Number Index to find the NSN, if assigned.

b. When National Stock Number or Part Number is Known.

- (1) **First.** Using the of National Stock Number and Part Number Indexes find the pertinent National Stock Number or Part Number. The NSN index is in National Item Identification Number (NIIN) sequence (see paragraph 4.a.). The part numbers in the Part Number index are listed in ascending alphanumeric sequence (see paragraph 4.b.). Both indexes cross-reference you to the illustration/figure and item number of the item you are looking for.
- (2) **Second.** Turn to the figure and item number, verify that the item is the one you are looking for, then locate the item number in the repair parts list for the figure.

7. ABBREVIATIONS. Abbreviations used in this manual are listed in MIL-STD-12

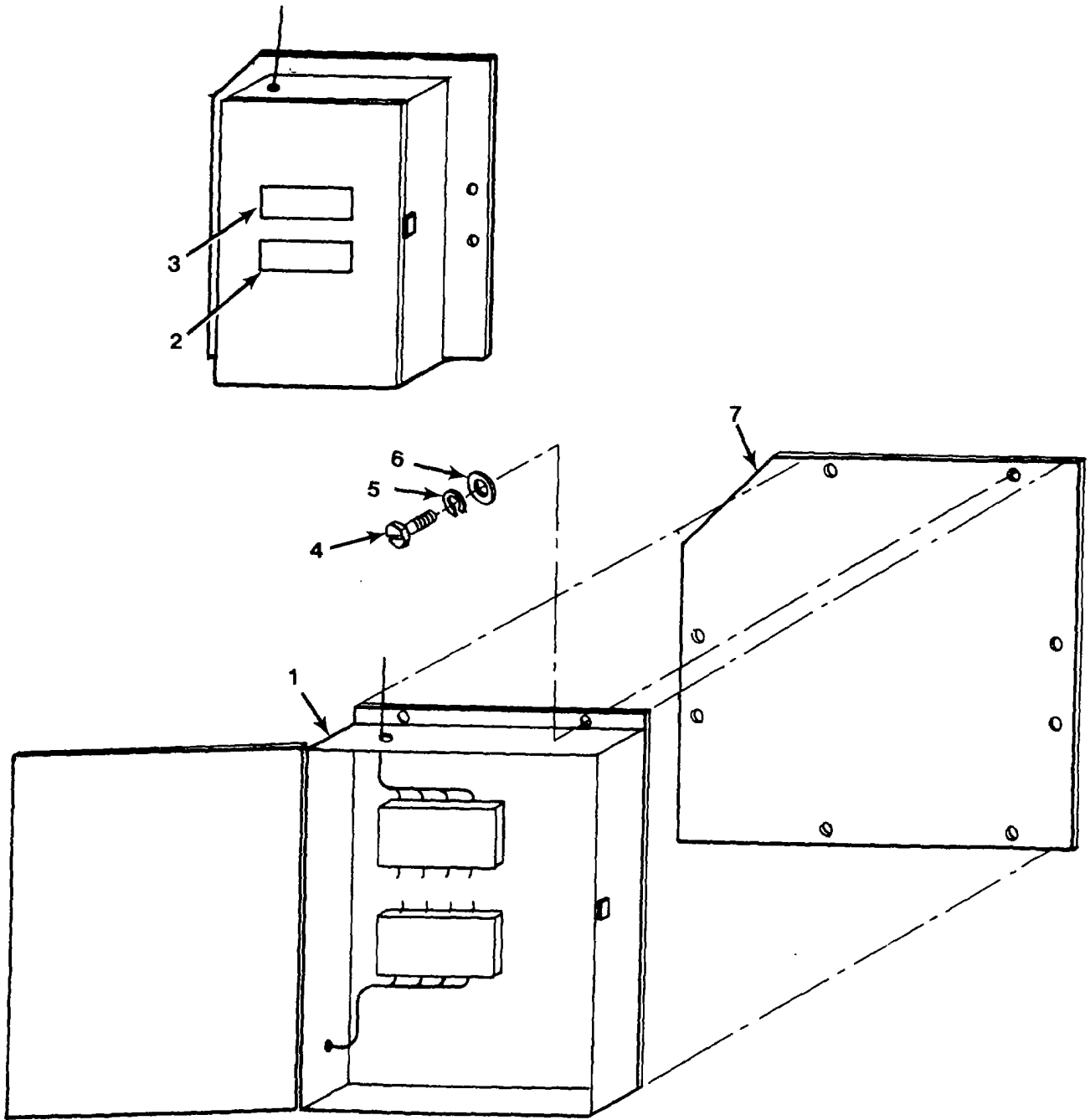

Figure 1. Power Filter Assembly

SECTION II

TM 5-3610-293-13&P

(1) ITEM NO	(2) SMR CODE	(3) CAGEC	(4) PART NUMBER	(5) DESCRIPTION AND USABLE ON CODES(UOC)	(6) QTY
GROUP 01 ISATROL CONTROL BOX					
FIG. 1 POWER FILTER ASSEMBLY					
1	XDOZZ	81337	5-13-4992	FILTER,PWR LINE ASS.....	1
2	XDOZZ	81337	5-13-5020	.DECAL	1
3	XDOZZ	81337	5-13-4720	.STENCIL,.25,BLACK TURN OFF	1
				.BREAKER BEFORE SERVICE	
4	XDOZZ	96906	MS90725-6	.SCREW,CAP,HEXAGON H.....	4
5	XDOZZ	96906	MS35338-44	.WASHER,LOCK.....	4
6	XDOZZ	96906	MS15795-410	.WASHER,FLAT.....	4
7	XDOZZ	81337	5-13-5032	.PLATE,MTG PWR FIL	1

END OF FIGURE

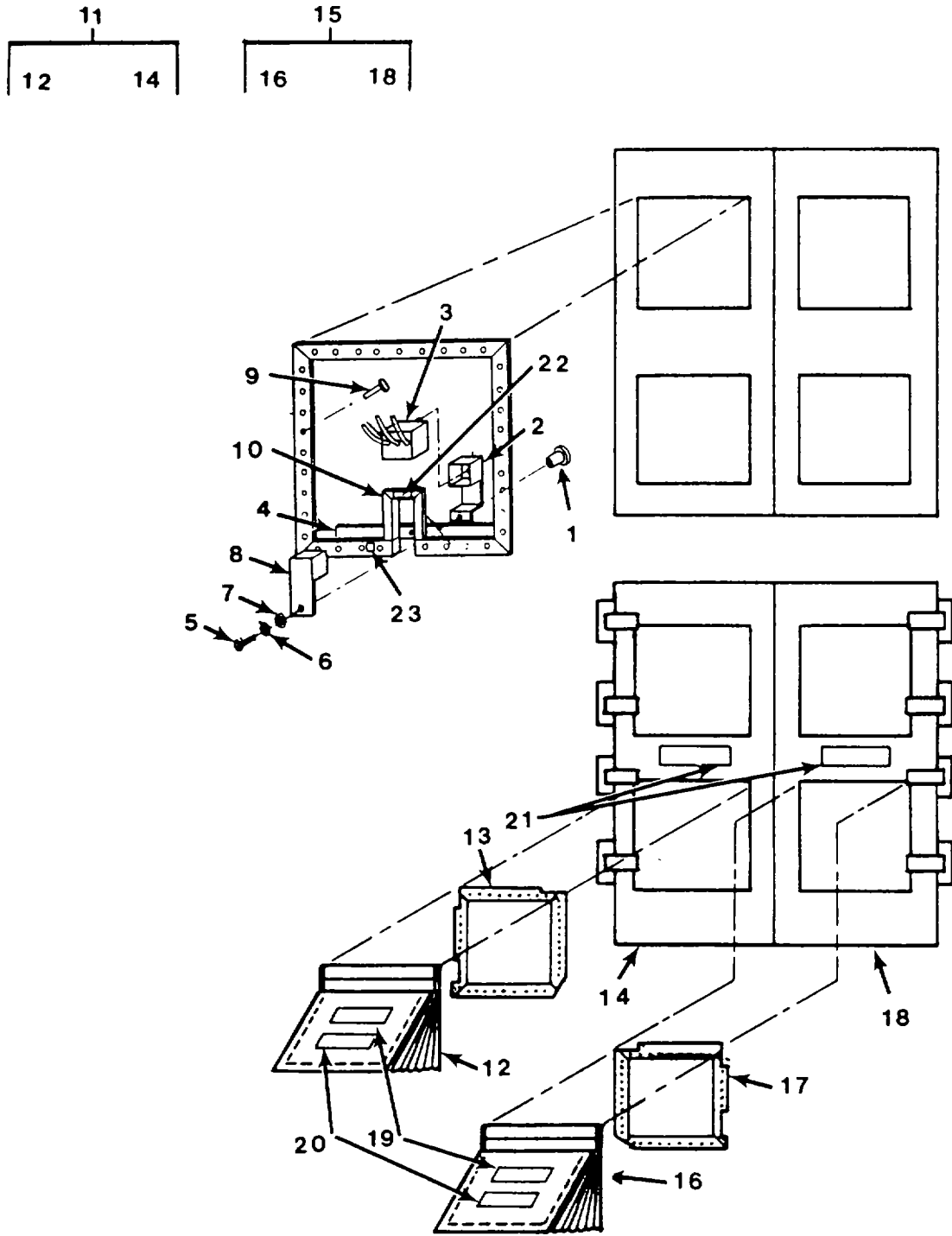

Figure 2. Cargo Door Vent Installation

Change 1 F-12

SECTION II

TM 5-3610-293-13&P

(1) ITEM NO	(2) SMR CODE	(3) CAGEC	(4) PART NUMBER	(5) DESCRIPTION AND USABLE ON CODES(UOC)	(6) QTY
GROUP 02 CARGO DOOR VENT ASSEMBLY					
FIG. 2 CARGO DOOR VENT INSTALLATION					
	XCOOO	81337	5-13-4968	SW, VENT DR INSTL.....	1
1	XDOZZ	96906	MS27130-A20	.NUT, BLIND RIVET	4
2	XDOZZ	81337	5-13-5007	.SPT, SL.....	4
3	PAOZZ	09353	8168	.SWITCH, PUSH	4
4	XDOZZ	81337	5-13-5008	.BRACKET, SN	4
5	XDOZZ	96906	MS35191-274	.SCREW, MACHINE.....	4
6	XDOZZ	96906	MS35338-43	.WASHER, LOCK.....	4
7	XDOZZ	96906	MS15795-408	.WASHER, FLAT.....	4
8	XDOZZ	81337	5-13-5006	.CVR, PUSH SN.....	4
9	XDOZZ	81349	MIL-R-24243/6-A4 04H	.RIVET	32
10	XDOZZ	81337	5-13-4996	.FRAME, FILTER	4
11	XCOOO	81337	5-13-4998	.VENT INSTL LEFT	1
12	XDOZZ	81337	5-4-3042	..VENTILATOR, AIR CIRC SEE TM10- 5411-200-24P FOR PARTS BREAKDOWN.....	1
13	XDOZZ	81337	5-13-4995	..FRAME, LEFT VENT	1
14	XDOZZ	81337	5-13-5015	..DOOR VENT, LEFT	1
15	XCOOO	81337	5-13-4999	.VENT INSTL, RIGHT.....	1
16	XDOZZ	81337	5-4-3042	..VENTILATOR, AIR CIRC SEE TM10- 5411-200-24P FOR PARTS BREAKDOWN.....	1
17	XDOZZ	81337	5-13-4994	..FRAME, RIGHT VENT	1
18	XDOZZ	81337	5-13-5014	..DR, RT, VET	1
19	XDOZZ	81337	5-13-4719	.STENCIL, 1.0IN BLACK CAUTION.....	4
20	XDOZZ	81337	5-13-4822	.STENCIL, .5, BLACK DOOR UNDER..... SPRING TENSION.....	4
21	XDOZZ	81337	5-13-4719	.STENCIL, 1.0 IN BLACK BEFORE..... OPERATING A/C VENT DOORS MUST BE OPEN.....	2
22	XDOZZ	81337	5-13-4720	..STENCIL, .25, BLACK 24VAC.....	1
23	XDOZZ	81337	5-13-4720	..STENCIL, .25, BLACK 56, 57, 58, 59.....	4

END OF FIGURE

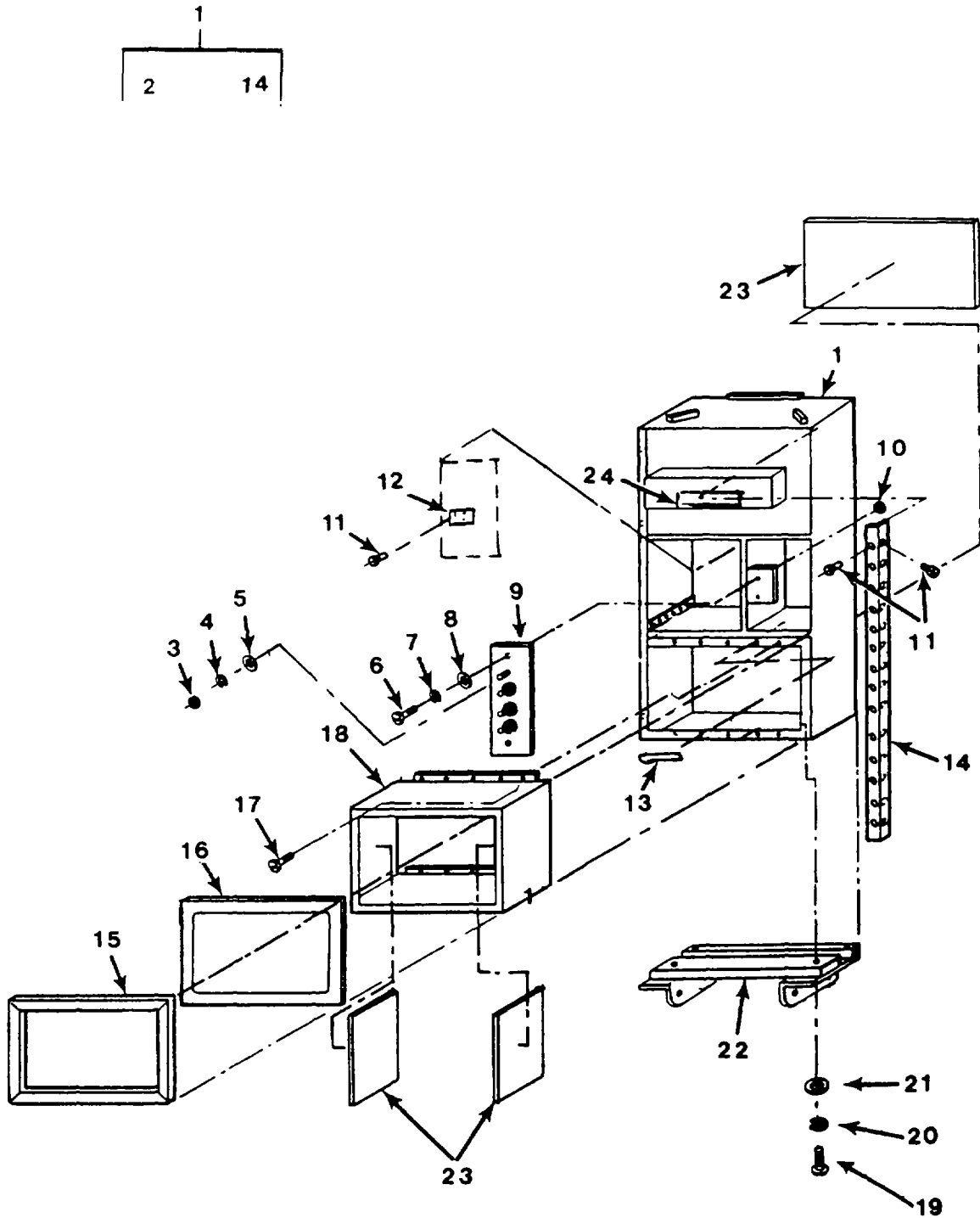

Figure 3. 24K Air Conditioner Installation
F-14 Change 1

SECTION II

TM 5-3610-293-13&P

(1) ITEM NO	(2) SMR CODE	(3) CAGEC	(4) PART NUMBER	(5) DESCRIPTION AND USABLE ON CODES(UOC) GROUP 03 AIR CONDITIONER ASSEMBLY FIG. 3 24K AIR CONDITIONER INSTALLATION	(6) QTY
1	PBOFF	81337	5-13-4900	.AIR CONDITIONER	1
2	XAOFF	81337	5-13-4733	..224K HEAT PUMP	1
3	XDOZZ	96906	MS35650-5	..NUT, PLAIN, HEX	4
4	XDOZZ	96906	MS35338-140	..WASHER, LOCK.....	4
5	XDOZZ	96906	MS15795-812	..WASHER, FLAT.....	4
6	XDOZZ	96906	MS51957-30	..SCREW, MACHINE.....	2
7	XDOZZ	96906	MS35338-136	..WASHER, LOCK.....	2
8	XDOZZ	96906	MS15795-805	..WASHER, FLAT.....	2
9	XDOZZ	81337	5-13-5031-2	..TERMINAL BD	1
10	XDOZZ	96906	MS35649-264	..NUT, PLAIN, HEXAGON.....	2
11	XDOZZ	81349	MIL-R-24243/3B40 4	..RIVET, BLIND	100
12	XDOZZ	81337	5-13-4713-2	..PLATE, CVR	1
13	PAOZZ	96906	MS3368-1-OB	..STRAP, TIEDOWN, ELECT	25
14	XDOZZ	81337	5-13-4900-17	..BRACE, ANGLE.....	4
15	XDOZZ	81337	5-13-4927-1	..FRAME, COND, AIR OUT	1
16	XDOZZ	39428	8614K23	.GASKET.....	V
17	XDOZZ	96906	MS24630-48	.SCREW, TAP, #IOX.75	6
18	XDOZZ	81337	5-13-4930	..ASSY AIR OUTLET HSG	1
19	XDOZZ	96906	MS90728-8	SCREW, CAP, HEXAGON H 25 X 20 X 1.00.....	6
20	XDOZZ	96906	MS35338-44	..WASHER, LOCK.....	6
21	XDOZZ	96906	M515795-410	..WASHER, FLAT.....	6
22	XDOZZ	81337	5-13-4932	..BRACKET, SPT	1
23	XDOZZ	39428	9385K21	..INSUL, FOAM	3
24	XDOZZ	81337	5-13-4822	..STENCIL, 1.0, BLACK OPEN DOOR FOR FRESH AIR INTAKE	1

END OF FIGURE

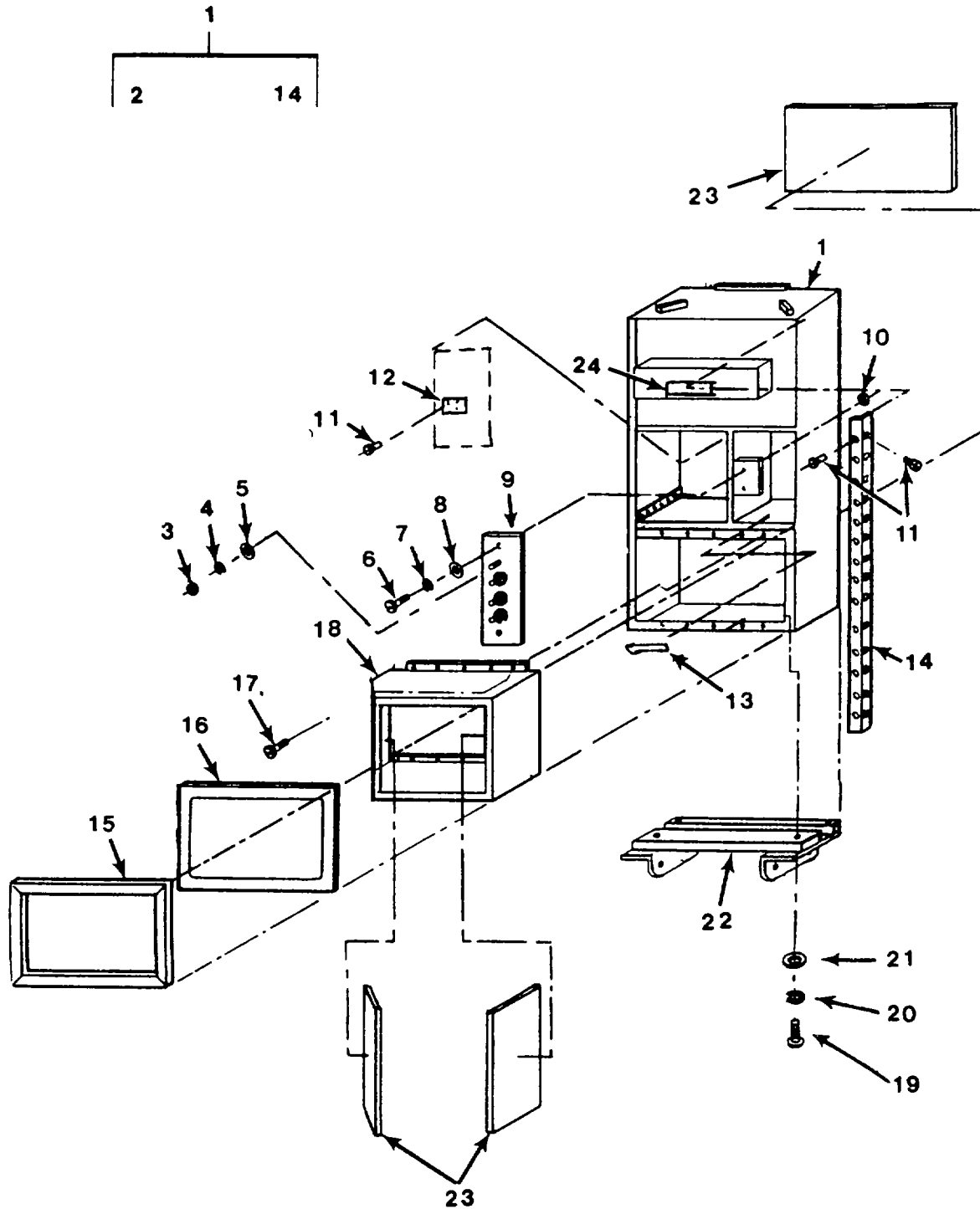

Figure 4. 36K Air Conditioner Installation

F-16 Change 1

SECTION II

TM 5-3610-293-13&P

(1) ITEM NO	(2) SMR CODE	(3) CAGEC	(4) PART NUMBER	(5) DESCRIPTION AND USABLE ON CODES(UOC)	(6) QTY
GROUP 03 AIR CONDITIONER ASSEMBLY					
FIG. 4 36K AIR CONDITIONER INSTALLATION					
1	PBOFF	81337	5-13-4904	..AIR CONDITIONER	1
2	XAOFF	81337	5-13-4763	..36K HEAT PUMP	1
3	XDOZZ	96906	MS35650-5	..NUT, PLAIN, HEX	4
4	XDOZZ	96906	MS35338-140	..WASHER, LOCK.....	4
5	XDOZZ	96906	MS15795-812	..WASHER, FLAT.....	4
6	XDOZZ	96906	MS51957-30	..SCREW, MACHINE.....	2
7	XDOZZ	96906	MS35338-136	..WASHER, LOCK.....	2
8	XDOZZ	96906	M515795-805	..WASHER, FLAT.....	2
9	XDOZZ	81337	5-13-5031-1	..TERMINAL BD	1
10	XDOZZ	96906	MS35649-264	..NUT, PLAIN, HEXAGON	2
11	XDOZZ	81349	MIL-R-24243/3B40 4	..RIVET, BLIND	100
12	XDOZZ	81337	5-13-4713-1	..PLATE, CVR	1
13	PAOZZ	96906	MS3368-1-OB	..STRAP, TIEDOWN, ELECT	25
14	XDOZZ	81337	5-13-4904-17	..BRACE, ANGLE.....	4
15	XDOZZ	81337	5-13-4927-2	..FRAME, AIR OUTLET	1
16	XDOZZ	39428	8614K23	..GASKET .5X1.5.....	V
17	XDOZZ	96906	MS24630-48	..SCREW, TAP, 10X.75.....	6
18	XDOZZ	81337	5-13-4931	..ASSY, AIR OUTLET HSG	1
19	XDOZZ	96906	MS90275-8	..SCREW, MACHINE 25 X 20 X 1.00.....	6
20	XDOZZ	96906	MS35338-44	..WASHER, LOCK.....	6
21	XDOZZ	96906	MS15795-410	..WASHER, FLAT.....	6
22	XDOZZ	81337	5-13-4936	..BRACKET, SPT	1
23	XDOZZ	39428	9385K21	..INSUL, FOAM 20 X 20 INCHES	3
24	XDOZZ	81337	5-13-4822	..STENCIL, 1.0, BLACK OPEN DOOR FOR..... FRESH AIR INTAKE	1

END OF FIGURE

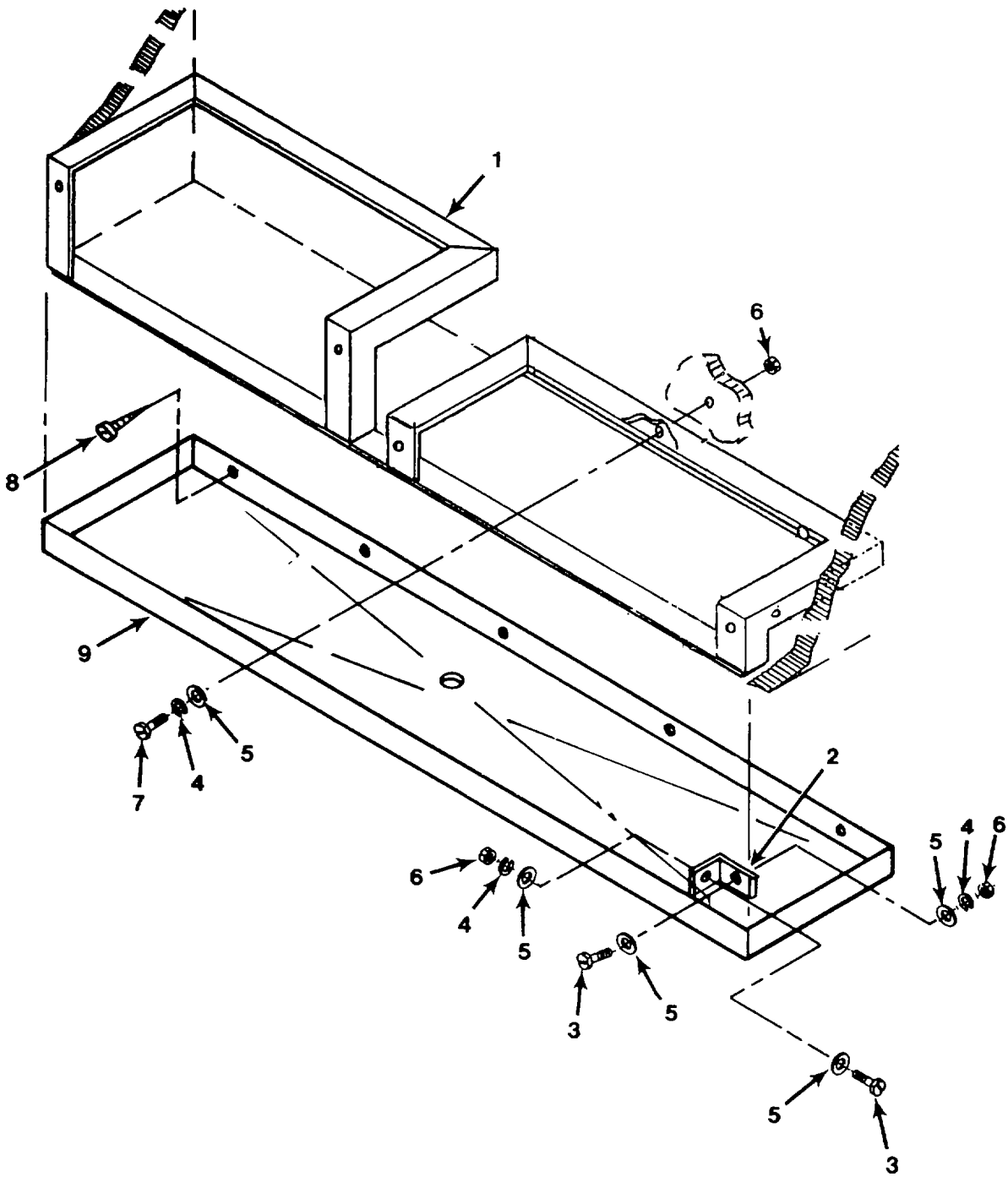

Figure 5. Air Conditioner Mounting Bracket Assembly

SECTION II

TM 5-3610-293-13&P

(1) ITEM NO	(2) SMR CODE	(3) CAGEC	(4) PART NUMBER	(5) DESCRIPTION AND USABLE ON CODES(UOC)	(6) QTY
GROUP 03 AIR CONDITIONER ASSEMBLY					
FIG. 5 AIR CONDITIONER MOUNTING BRACKET ASSEMBLY					
1	XDOZZ	81337	5-13-4922	BRACKET, MTG, AC ASSY	1
2	XDOZZ	81337	5-13-4940	.CLIP, ANGLE, AC	2
3	XDOZZ	96906	MS51849-95	.SCREW, MACHINE.....	4
4	XDOZZ	96906	MS35338-44	.WASHER, LOCK.....	14
5	XDOZZ	96906	MS15795-410	.WASHER, FLAT.....	14
6	XDOZZ	96906	MS35649-2252	.NUT, PLAIN, HEXAGON	14
7	XDOZZ	96906	MS90725-13	.SCREW, CAP	10
8	XDOZZ	96906	MS51861-37	.SCREW, TAPPING, THREA	10
9	XDOZZ	81337	5-13-5011	.PAN, DRIP, AC	1

END OF FIGURE

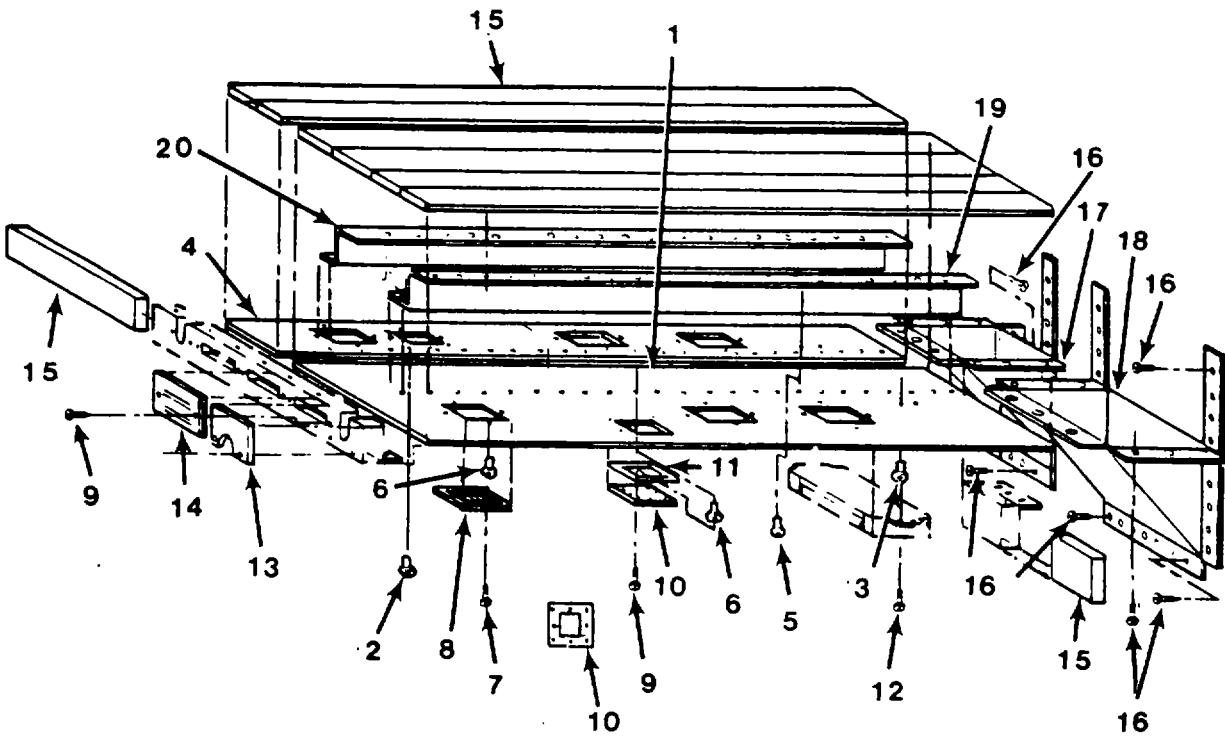

Figure 6. Duct Installation

SECTION II

TM 5-3610-293-13&P

(1) ITEM NO	(2) SMR CODE	(3) CAGEC	(4) PART NUMBER	(5) DESCRIPTION AND USABLE ON CODES(UOC)	(6) QTY
GROUP 04 DUCTING ASSEMBLY, AIR CONDITIONER					
FIG. 6 DUCT INSTALLATION					
	XCDDD	81337	5-13-4962	..DUCT INSLT	1
1	XDDZZ	81337	5-13-4966	..PANEL, DUCT, LG	1
2	XDOZZ	96906	MS27130-A19	..NUT, BLIND RIVET	1
3	XDOZZ	96906	MS27130-A31	..NUT, BLIND RIVET 1/4-20UNC.....	4
4	XDDZZ	81337	5-13-4967	..PANEL, DUCT, SMALL	1
5	XDOZZ	96906	MS27130-A31	..NUT, BLIND RIVET 3/16-32	4
6	XDOZZ	96906	MS27130-A19	..NUT, BLIND RIVET	20
7	XDOZZ	96906	MS35191-47	..SCREW, MACHINE 82DEG, 10-32 X .75.....	24
8	XDOZZ	9R714	C808-4	..REGISTER, FOUR WAY	6
9	XDOZZ	96906	M535207-264	..SCREW, MACHINE 10-32 X .5.....	22
10	XDOZZ	81337	5-13-4959	..PLATE, ACC, SOLAR BAR	2
11	XDOZZ	81349	M6855/1-1012	..GASKET, RUBBER	1
12	XDOZZ	96906	MS90725-6	..SCREW, CAP, HEXAGON H.....	8
13	XDOZZ	81337	5-13-4956	..CVR, SOLAR BAR	2
14	XDOZZ	9R714	C93-15	..DEFUSER, LEN AL	3
15	XDDZZ	39428	9350K1	..INSUL, FIBER GL.....	V
16	XDDZZ	96906	MS51861-47	..SCREW, TAPPING, THREA 10 X .75	31
17	XDDZZ	81337	5-13-4954	..TRANSITION, SMALL	1
18	XDDZZ	81337	5-13-4955	..TRANSITION, LARGE	1
19	XDDZZ	81337	5-13-4957-1	..Z BRACKET	1
20	XDDZZ	81337	5-13-4957-2	..Z BRACKET	1

END OF FIGURE

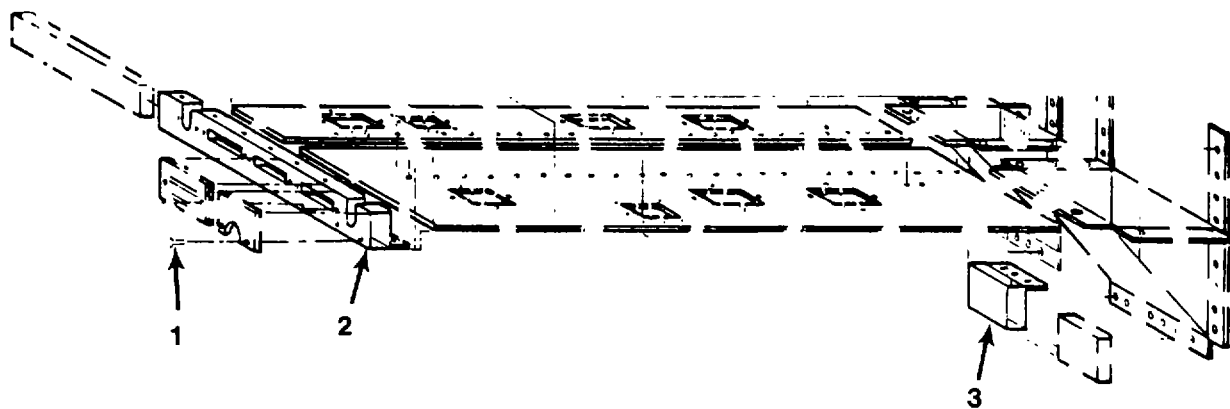

Figure 7. Ductwork Cap Installation

SECTION II

TM 5-3610-293-13&P

(1) ITEM NO	(2) SMR CODE	(3) CAGEC	(4) PART NUMBER	(5) DESCRIPTION AND USABLE ON CODES(UOC)	(6) QTY
-------------------	--------------------	--------------	-----------------------	---	------------

GROUP 04 DUCTING ASSEMBLY, AIR CONDITIONER

FIG. 7 DUCTWORK CAP INSTALLATION

1	XDOZZ	81349	M24243/3B404	..RIVET, BLIND .18, 12-.25GRIP	284
2	XDDZZ	81337	5-13-4958	..CAP, DUCTWORK.....	1
3	XDDZZ	81337	5-13-4960	..CAP, DUCTWORK.....	1

END OF FIGURE

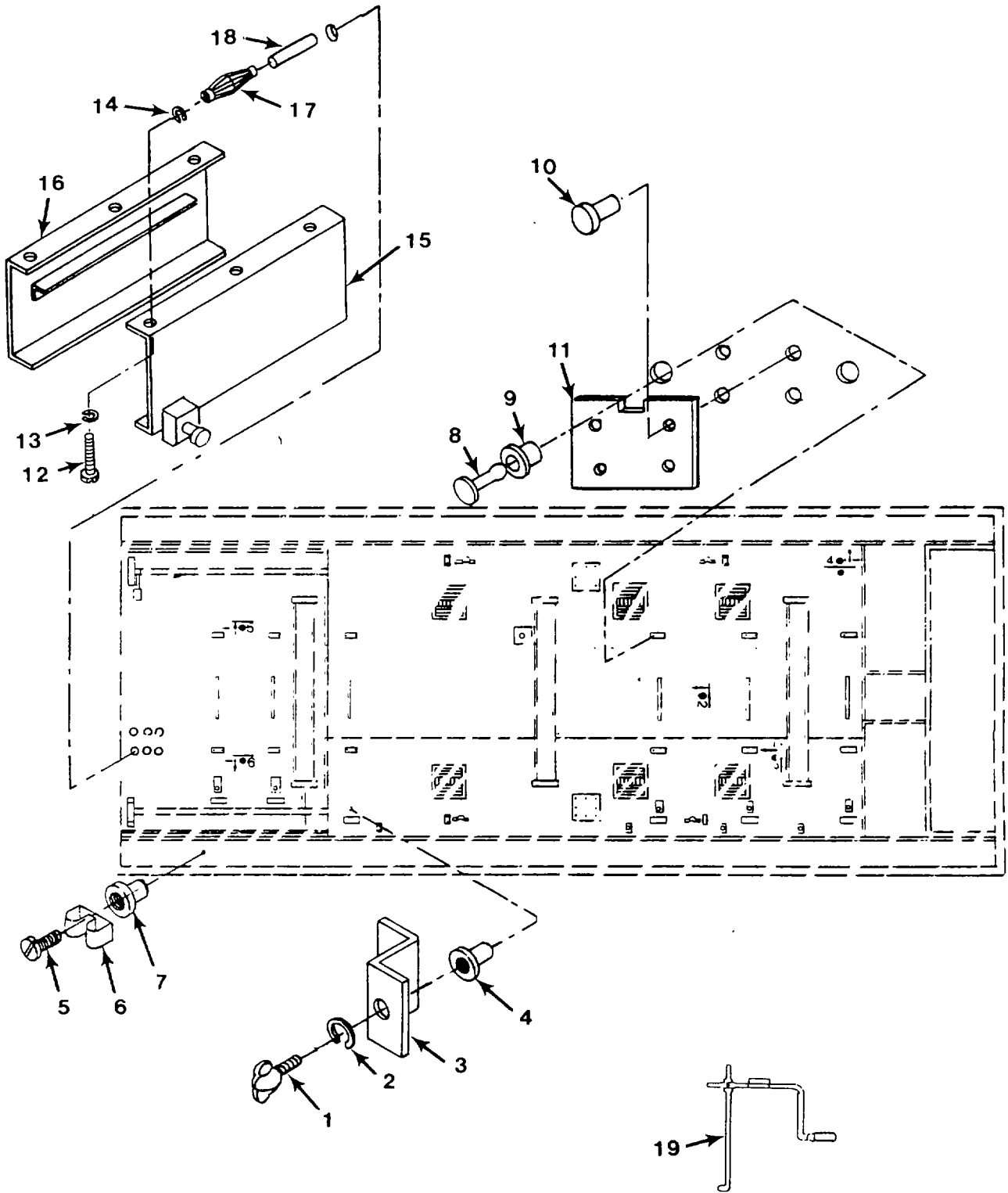

Figure 8. Light Storage Assembly

SECTION II

TM 5-3610-293-13&P

(1) ITEM NO	(2) SMR CODE	(3) CAGEC	(4) PART NUMBER	(5) DESCRIPTION AND USABLE ON CODES(UOC)	(6) QTY
	XCOOO	81337	5-13-4963	LIGHT STOR ASSY	1
1	XDOZZ	96906	MS21316-36	.THUMBSCREW	6
2	XDOZZ	96906	MS35335-33	.WASHER, LOCK.....	6
3	XDOZZ	81337	5-13-4923	.CLIP, LT TRANSPORT	6
4	XDOZZ	96906	MS27130-A31	.NUT, BLIND RIVET	6
5	XDOZZ	96906	MS35206-245	.SCREW, MACHINE.....	6
6	XDOZZ	81337	5-4-5106	.CLIP, SPRING TENSION	6
7	XDOZZ	96906	MS27130-A13	.NUT, PLAIN, BLIND RIV	6
8	XDOZZ	81337	5-4-5107	.STUD, DBL HEAD.....	24
9	XDOZZ	96906	MS27130-A37	.NUT, BLIND, RIVET	24
10	XDOZZ	96906	MS20601-AD4W4	.RIVET, BLIND	48
11	XDOZZ	81337	5-4-3019	.BRACKET, MOUNTING	12
12	XDOZZ	96906	MS90726-12	.SCREW, HEXAGON HD	6
13	XDOZZ	96906	MS35338-44	.WASHER, LOCK.....	6
14	XDOZZ	96906	MS15795-410	.WASHER, FLAT.....	6
15	XDOZZ	81337	5-13-5054	.HANGER, JACK, R	1
16	XDOZZ	81337	5-13-5053	.HANGER, JACK, L.....	1
17	XDDZZ	81337	5-4-4934	.EXPANDER.....	6
18	XDDZZ	81337	5-4-4831	.SLEEVE	6
19	XDOZZ	81337	5-13-5055	.HANDLE, JACK, MOD.....	2

GROUP 04 DUCTING ASSEMBLY, AIR CONDITIONER

FIG. 8 LIGHT STORAGE ASSEMBLY

END OF FIGURE

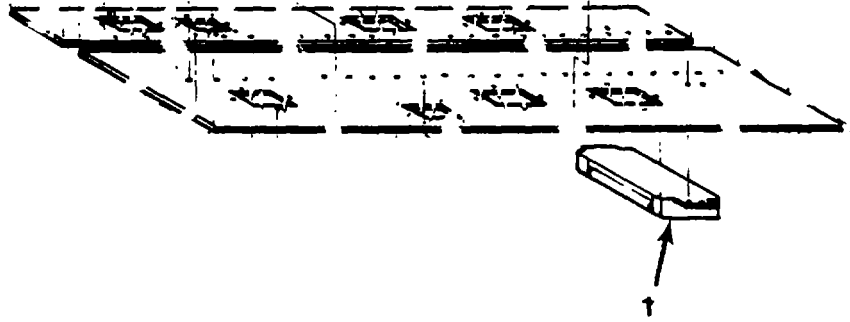

Figure 9. Fixed Roof Light Assembly

SECTION II

TM 5-3610-293-13&P

(1) ITEM NO	(2) SMR CODE	(3) CAGEC	(4) PART NUMBER	(5) DESCRIPTION AND USABLE ON CODES(UOC)	(6) QTY
-------------------	--------------------	--------------	-----------------------	---	------------

GROUP 05 CEILING LIGHT ASSEMBLY

FIG. 9 FIXED ROOF LIGHT ASSEMBLY

1	XDOOO	81337	5-4-2954		
---	-------	-------	----------	--	--

..LT ASSY, FIXED ROOF SEE TM10-5411-..... 2
200-24P FOR PARTS BREAKDOWN.....

END OF FIGURE

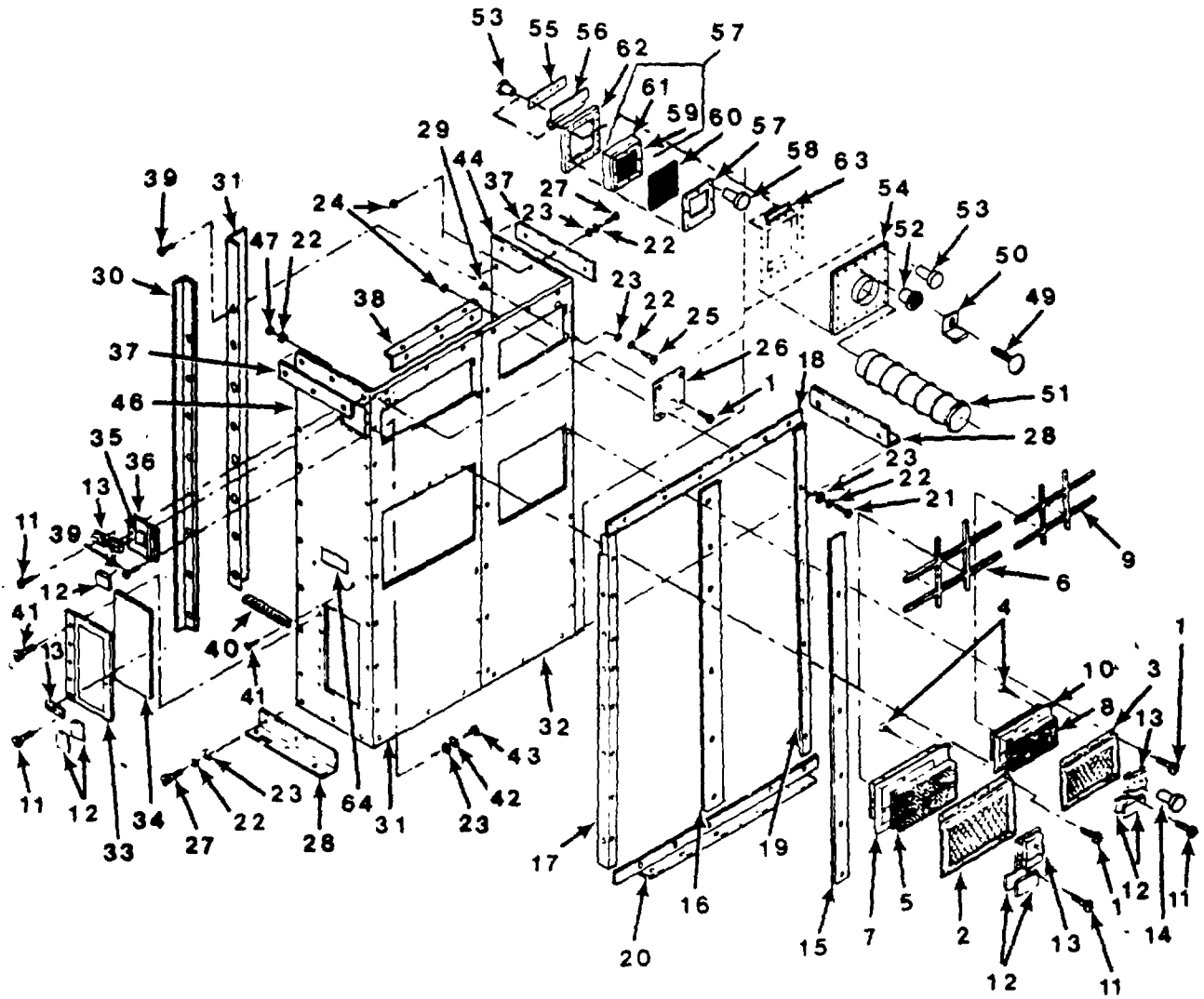

Figure 10. Air Conditioner Housing Installation

SECTION II

TM 5-3610-293-13&P

(1) ITEM NO	(2) SMR CODE	(3) CAGEC	(4) PART NUMBER	(5) DESCRIPTION AND USABLE ON CODES(UOC)	(6) QTY
GROUP 06 HOUSING ASSEMBLY, AIR CONDITIONER					
FIG. 10 AIR CONDITIONER HOUSING INSTALLATION					
	XCDDD	81337	5-13-4889	HSING, A/C.....	1
1	XDOZZ	96906	MS24630-48	.SCREW, TAP, 10X.75.....	27
2	XDOZZ	81337	5-13-4914-2	.VENT, BOTTOM L.....	1
3	XDOZZ	81337	5-13-4114-1	.VENT, BOTTOM R.....	1
4	XDDZZ	96906	MS51862-12C	.SCREW, TAP.....	24
5	PAOZZ	39428	2069K11	.FILTER MEDIA, AIR CO.....	1
6	XDOZZ	81337	5-13-4917-1	.SPT, FILTER.....	1
7	XDOZZ	81337	5-13-4918-1	.FRAME, FILTER.....	1
8	PAOZZ	39428	2069K11	.FILTER MEDIA, AIR CO.....	1
9	XDOZZ	81337	5-13-4917-2	.SPT, FILTER.....	1
10	XDOZZ	81337	5-13-4918-2	.FRAME, FILTER.....	1
11	XDOZZ	96906	MS51861-47	.SCREW, TAPPING, THREA.....	3
12	XDDZZ	81337	5-13-4889-44	.SHEET, ALUMINUM.....	13
13	XDOZZ	39428	1664AS	.LATCH, CABINET.....	7
14	XDOZZ	81349	MIL-R-24243/6-A4 05H	.RIVET.....	24
15	XDDZZ	82685	5K809	.BAR, DIVISION.....	1
16	XDDZZ	82685	5K809	.BAR, DIVISION.....	1
17	XDDZZ	81337	5-13-4895	.SPT, A/C HSNL LFB.....	1
18	XDDZZ	81337	5-13-4892	.SPT, A/C HSNL FPTF.....	1
19	XDDZZ	81337	5-13-4894	.SPT, A/C HSNL RFV.....	1
20	XDDZZ	81337	5-13-4891	.SPT, A/C HSNL FPBF.....	1
21	XDDZZ	96906	MS90728-8	.SCREW, CAP, HEXAGON H.....	25
22	XDDZZ	96906	MS35338-44	.WASHER, LOCK.....	52
23	XDDZZ	96906	MS15795-410	.WASHER, FLAT.....	52
24	XDDZZ	39428	90975A029	.NUT, TEE.....	55
25	XDDZZ	96906	MS90725-13	.SCREW, CAP.....	3
26	XDDZZ	81337	5-13-4919	.CVR, SOLAR BAR.....	2
27	XDDZZ	96906	MS90725-6	.SCREW, CAP, HEXAGON H.....	27
28	XDDZZ	81337	5-13-4896	.SPT, A/C HSNL SPB.....	2
29	XDDZZ	96906	MS35649-2252	.NUT, PLAIN, HEXAGON.....	3
30	XDDZZ	81337	5-13-4902	.WALL ASSY HSNL.....	1
31	XDDZZ	81337	5-13-4905	.WALL ASSY AC HSNLFR.....	1
32	XDDZZ	81337	5-13-4893	.SPT, A/C HSNL FPTR.....	1
33	XDOZZ	81337	5-13-4916-2	.VENT, AIR RTN.....	1
34	PAOZZ	39428	2069K11	.FILTER MEDIA, AIR CO.....	1
35	XDOZZ	81337	5-13-4822	.STENCIL, .5, BLACK ACCESS TO FURNACE HEAT STR IPS.....	1
36	XDOZZ	81337	5-13-4911	.DOOR, HTR ACC.....	1
37	XDDZZ	81337	5-13-4901	.SPT, A/C HSNL SPR.....	2
38	XDDZZ	81337	5-13-4890	.SPT, A/C HSNL L TOP.....	1
39	XDOZZ	96906	MS35191-291	.SCREW, MACHINE.....	16
40	XDOZZ	81337	5-13-4912	.RACK, STORAGE, TIEDOW.....	1
41	XDOZZ	96906	MS24693-26	.SCREW, MACHINE.....	4
42	XDOZO	96906	MS35333-37	.WASHER, LOCK.....	4
43	XDOZZ	96906	MS35649-262	.NUT, PLAIN, HEXAGON.....	4

SECTION II

TM 5-3610-293-13&P

(1) ITEM NO	(2) SMR CODE	(3) CAGEC	(4) PART NUMBER	(5) DESCRIPTION AND USABLE ON CODES(UOC)	(6) QTY
44	XDDZZ	81337	5-13-4898	.WALL ASSY AC HSNG L.....	1
45	XDDZZ	81337	5-13-4897	.SPT, A/C HSNG RSPT.....	1
46	XDDZZ	81337	5-13-4908	.WALL ASSY AC HSNG R.....	1
47	XDDZZ	39428	90975A029	.NUT, TEE.....	8
48	XDDZZ	74222	30-99-142-12	.RIVET, DR..... V	
49	XDOZZ	96906	MSS21316-36	.THUMBSCREW 10-32X.75.....	1
50	XDOZZ	81337	5-13-5064	.CLIP, VENT TUBE.....	1
51	XDOZZ	39428	5266K59	.DUCT, HOSE.....	1
52	XDOZZ	96906	MS27130-A26	.NUT, RIVET.....	1
53	XDOZZ	96906	MS20600-B6W3	.RIVET, BLIND.....	46
54	XDOZZ	81337	5-13-5042	.FRAME, VENT, INNER.....	1
55	XDOZZ	81337	5-13-5021	.STRIP, VENT, OUT.....	1
56	XDOZZ	81337	5-13-5040	.FLAP, RUBBER.....	1
57	XDOOO	81337	5-13-5046	.FRAME, VENT, OUTER.....	1
58	XDOZZ	96906	MS20600-B6W5	..RIVET, BLIND.....	8
59	XDOZZ	81337	5-13-5043	..PLATE, BACK, VENT.....	2
60	XDOZZ	39428	1224T25	..SCREEN, MESH.....	1
61	XDOZZ	81337	5-13-5044	..BOX, SLATS, VENT.....	1
62	XDOZZ	81337	5-13-5045	..PLATE, FRONT, VENT.....	1
63	XDOZZ	81337	5-13-4822	.STENCIL, .5, BLACK.....	1
64	XDOZZ	81337	5-13-4822	.STENCIL, .5, BLACK RUBBER STRAP..... STORAGE.....	1

END OF FIGURE

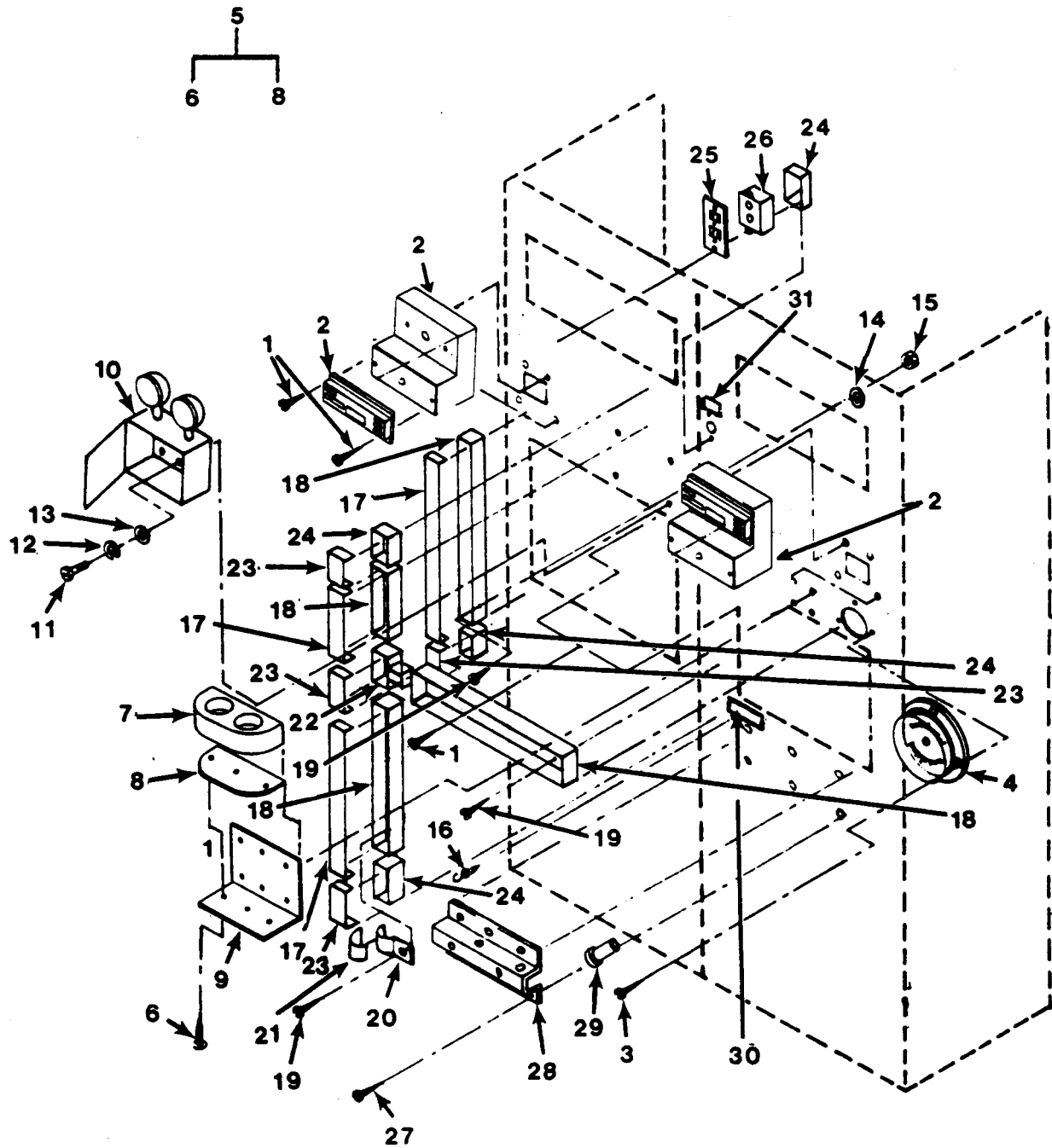

Figure 11. Air Conditioner Housing Equipment Mounting Installation

(1) ITEM NO	(2) SMR CODE	(3) CAGEC	(4) PART NUMBER	(5) DESCRIPTION AND USABLE ON CODES(UOC)	(6) QTY
GROUP 06 HOUSING ASSEMBLY, AIR CONDITIONER					
FIG.11 AIR CONDITIONER HOUSING EQUIPMENT MOUNTING INSTALLATION					
1	XCOOO XDOZZ	81337 96906	5-13-4888 MS51861-37	ASSY, EQUIP MTG A/CSCREW, TAPPING, THREA PAN HD, TYPE AB, #8 X .75	1 7
2	XDOOO	81337	5-13-4972	.THERMOSTAT ASSY (SEE FIGURE 44 FOR PARTS BREAKDOWN)	2
3	XDOZZ	96906	MS24617-46	.SCREW, T AP, 10X1.00.....	7
4	PAOZZ	15806	HTAB-169	.HYGROMETER, DIAL IND	1
5	XDOOZ	81337	5-13-5005	.RACK, STORAGE, CAN.....	1
6	XDOZZ	96906	MS35492-253	..SCREW, WOOD, FLAT HD 8 X 1.00,..... BRASS	6
7	XDOZZ	97403	13226E7946	..GASKET, HOLDER.....	1
8	XDOZZ	97403	13226E7947	..HOLDER, SOLVENT CON	1
9	XDOZZ	97403	13226E7945	..SHELF, SOLVENT CON	1
10	PBOOO	81337	5-13-4780	.LIGHT UNIT, EMERGENC (SEE FIGURE 41 FOR PARTS BREAKDOWN).....	1
11	XDOZZ	96906	MS90725-11	.SCREW, HEX .25 X 20 X 1.38.....	4
12	XDOZZ	96906	MS35338-44	.WASHER, LOCK.....	4
13	XDOZZ	96906	MS15795-410	.WASHER, FLAT.....	4
14	XDOZZ	96906	MS15795-442	.WASHER, FLAT.....	4
15	XDOZZ	39428	90975A029	.NUT, TEE	4
16	XDOZZ	39428	9417K4	.HOOK, CUP, BRASS	1
17	XDOZZ	79725	G-2100C	.COVER, CONDUIT, RACEN	4
18	XDOZZ	79725	G-2100B	.RACEIJAY, METALLIC.....	2
19	XDOZZ	96906	MS35492-52	.SCREW, WOOD 8 X .75.....	30
20	XDOZZ	79725	2100WC	.CLIP, WIRE.....	20
21	XDOZZ	79725	G-2106	.CLIP, CVR.....	10
22	XDOZZ	79725	G-20115	.RACEWAY, TEE	1
23	XDOZZ	03743	180-A	.CVR, BLANK.....	4
24	XDOZZ	79725	G-2141	.BOX, RECP.....	5
25	XDOZZ	81345	UL 514AANDUL 514	.PLATE, WALL ELEC OUT.....	1
26	XDOZZ	81349	W-C-596/12-4	.CONN, RECP, ELEC.....	1
27	XDOZZ	96906	MS51861-67	.SCREW, TAPPING, THREA	6
28	XDOZZ	81337	5-13-4913-1	.SHEET, AL.....	1
29	XDOZZ	96906	MS27130-A32	.NUT, RIVET	2
30	XDOZZ	81337	5-13-4720	.STENCIL, .25, BLACK KEY STORAGE RACK.....	1
31	XDOZZ	81337	5-13-4720	.STENCIL, .25, BLACK RECEPTACLE 120V J-29 20A.....	1

END OF FIGURE

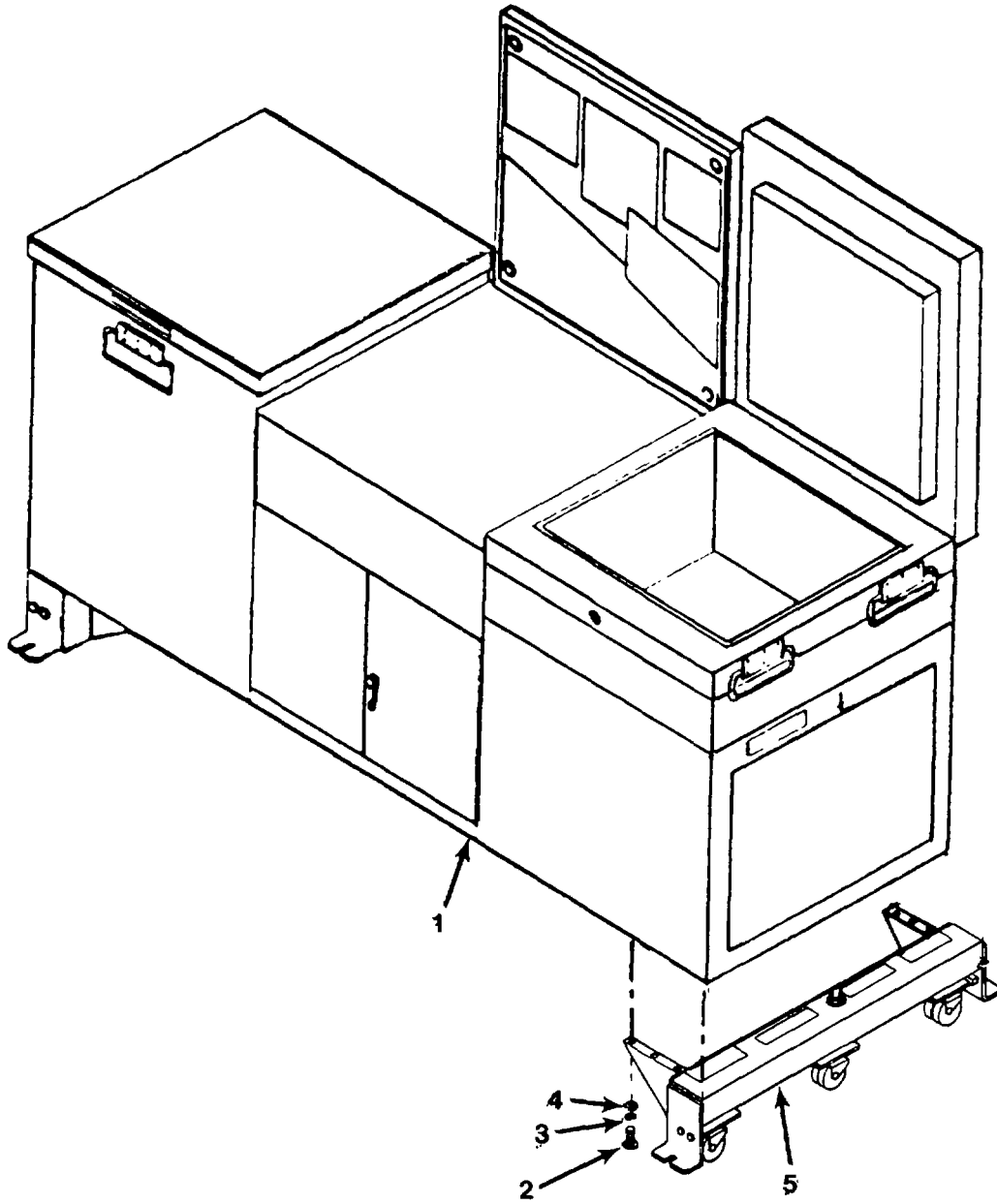

Figure 12. Ink Cart and Transporter Assembly

SECTION II

TM 5-3610-293-13&P

(1) ITEM NO	(2) SMR CODE	(3) CAGEC	(4) PART NUMBER	(5) DESCRIPTION AND USABLE ON CODES(UOC)	(6) QTY
-------------------	--------------------	--------------	-----------------------	---	------------

GROUP 07 INK CART AND TOOL CADDY ASSEMBLY

FIG. 12 INK CART AND TRANSPORTER ASSEMBLY

				
				ASSY, INK CART & TOO	1
1	XDODD	81337	5-13-4734	.INK CART & TOOL CAD	1
2	XDOZZ	96906	MS90728-8	.SCREW, CAP, HEXAGON H.....	16
3	XDOZZ	96906	MS35338-44	.WASHER, LOCK.....	16
4	XDOZZ	96906	MS15795-410	.WASHER, FLAT.....	16
5	XDOOO	81337	5-13-4703-3	TRANSPORTER ASSY	2

END OF FIGURE

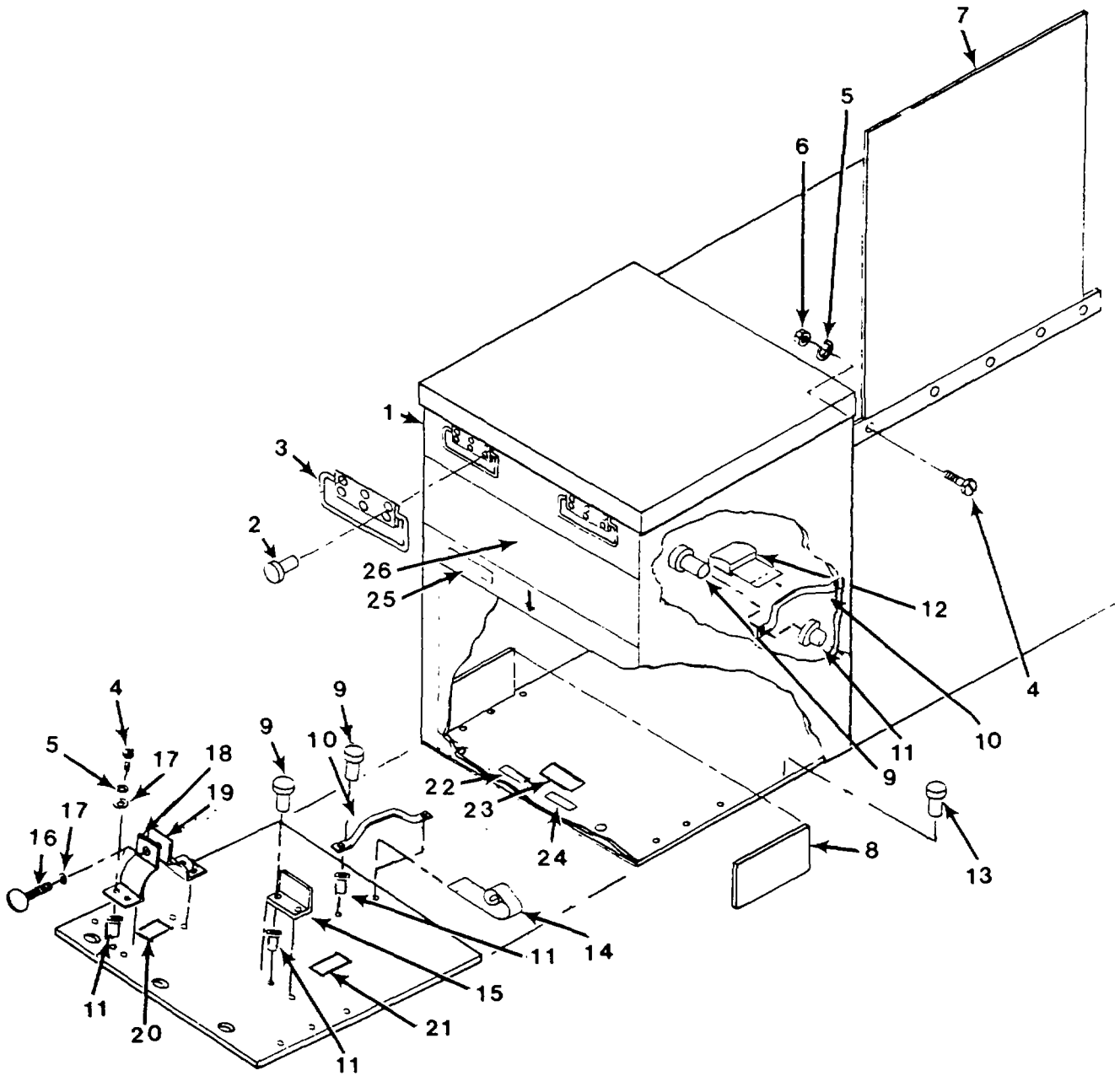

Figure 13. Ink Cart Assembly
(Sheet 1 of 2)

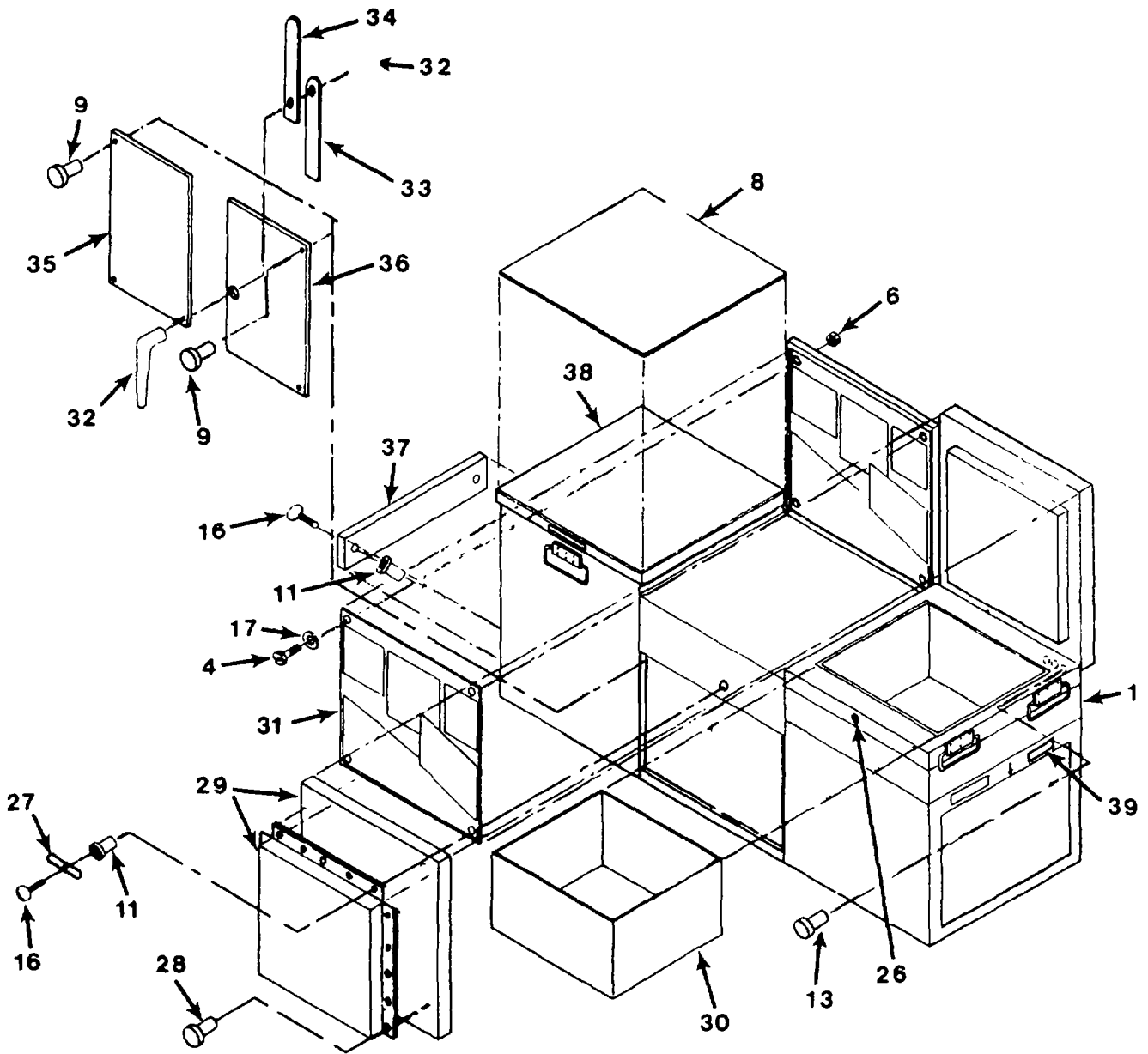

Figure 13. Ink Cart Assembly
(Sheet 2 of 2)

SECTION II

TM 5-3610-293-13&P

(1) ITEM NO	(2) SMR CODE	(3) CAGEC	(4) PART NUMBER	(5) DESCRIPTION AND USABLE ON CODES(UOC)	(6) QTY
GROUP 07 INK CART AND TOOL CADDY ASSEMBLY FIG.13 INK CART ASSEMBLY					
1	XAODD	2R621	PA19108	..CABINET, WORK CENTER	1
2	XDOZZ	96906	MS20600-MP4W6	..RIVET, BLIND	24
3	XDOZZ	98003	H5371BA	..HANDLE	4
4	XDOZZ	96906	MS90725-6	..SCREW, CAP, HEXAGON H.....	13
5	XDOZZ	96906	MS35338-44	..WASHER, LOCK.....	9
6	XDOZZ	96906	MS35649-2252	..NUT, PLAIN, HEXAGON	9
7	XDOZZ	81337	5-13-4735	..BACKPLATE, TOOL CADD.....	1
8	XDOZZ	81337	5-13-4734-4	..SHEET, RUBBER.....	V
9	XDOZZ	96906	MS20600-B6W6	..RIVET, BLIND	6
10	XDOZZ	96906	MS51939-1	..LOOP, STRAP FASTENER.....	2
11	XDOZZ	96906	MS27130-A31	..NUT	22
12	XDOZZ	97403	13226E7833-1	..STRAP & BUCKLE	1
13	XDOZZ	96906	MS20600-M4W2	..RIVET, BLIND	10
14	XDOZZ	97403	13226E7834-1	..ASSY, STRAP	1
15	XDOZZ	97403	13226E6991	..BRACKET, TOOL BX	1
16	XDOZZ	96906	MS21316-36	..THUMBSCREW	3
17	XDOZZ	96906	MS15795-410	..WASHER, FLAT.....	8
18	XDOZZ	97403	13226E6982-1	..BRACKET	1
19	XDOZZ	97403	13226E6982-2	..BRACKET	1
20	XDOZZ	81337	5-13-4822	..STENCIL, 1.O, BLACK.....	1
21	XDOZZ	81337	5-13-4822	..STENCIL, 1.0, BLACK TOOL BOX.....	1
STORAGE.....					
22	XDOZZ	81337	5-13-4758	..DECAL	2
23	XDOZZ	81337	5-13-4712	..DECAL	1
24	XDOZZ	81337	5-13-4759	..DECAL	2
25	XDOZZ	81337	5-13-4738	..DECAL	1
26	XDOZZ	81337	5-13-4736	..STENCIL, 1.O, RED	1
27	XDOZZ	97403	13226E6989	..BRACKET	1
28	XDOZZ	96906	MS20600-M4W3	..RIVET, BLIND	26
29	XDOZZ	81337	5-13-4743	..TOP, INK CART	1
30	XDOZZ	81337	5-13-4742	..LINER, INK CART	1
31	XDOZZ	81337	5-13-4732	..POUCH, TOOL.....	1
32	XDOZZ	94222	92-20-305-72	..HANDLE, DOOR	1
33	XDOZZ	94222	A5-21-074-10	..ROD, LATCH.....	1
34	XDOZZ	94222	A5-21-089-10	..ROD, LATCH.....	1
35	XDOZZ	81337	5-13-4744	..DOOR, LEFT.....	1
36	XDOZZ	81337	5-13-4745	..DOOR, RIGHT	1
37	XDOZZ	81337	5-13-4823	..BRACKET, SHIPPING.....	1
38	XDOZZ	81337	5-13-4737	..DECAL	1
39	XDOZZ	81337	5-13-4720	..STENCIL, .25, BLACK PRESS COVER.....	1
STORAGE.....					

END OF FIGURE

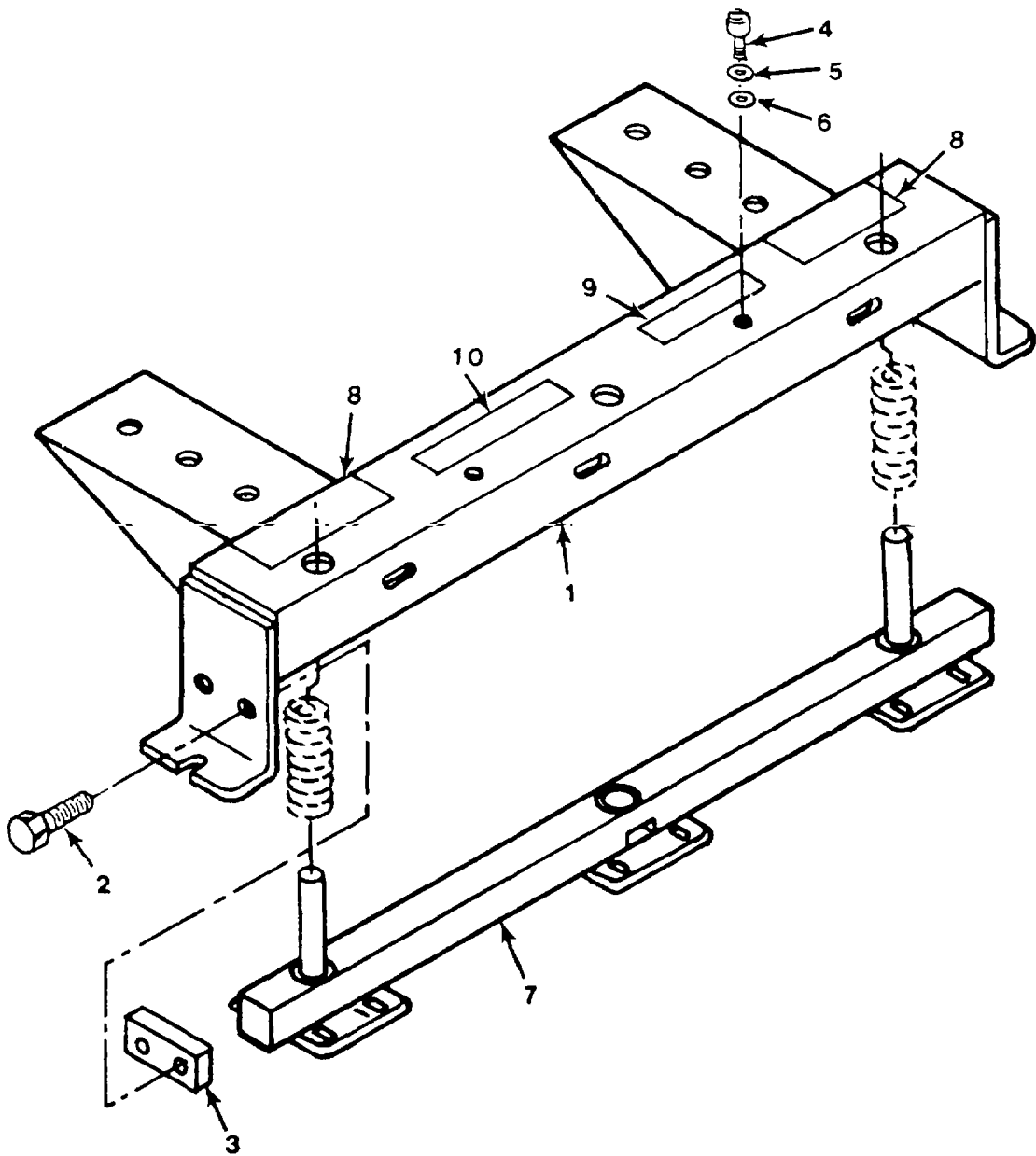

Figure 14. Transporter Assembly

F-40 Change 1

SECTION II

TM 5-3610-293-13&P

(1) ITEM NO	(2) SMR CODE	(3) CAGEC	(4) PART NUMBER	(5) DESCRIPTION AND USABLE ON CODES(UOC)	(6) QTY
-------------------	--------------------	--------------	-----------------------	---	------------

GROUP 07 INK CART AND TOOL CADDY ASSEMBLY

FIG.14 TRANSPORTER ASSEMBLY

1	XDOZZ	81337	5-13-4704-3	..HSING, TRANSPORTER	1
2	XDOZZ	96906	MS51095-303	..SCREW, HEX.....	4
3	XDOZZ	81337	5-13-4711	..STOP, CASTER BAR.....	2
4	XDOZZ	96906	MS16998-74	..SCREW, CAP, SOCKET HE	2
5	XDOZZ	96906	MS15795-417	..WASHER, FLAT.....	2
6	XDOZZ	96906	MS15795-414	..WASHER, FLAT.....	2
7	XDOZZ	81337	5-13-4705-3	..BAR, CASTER	1
8	XDOZZ	81337	5-13-4712	..DECAL	2
9	XDOZZ	81337	5-13-4759	..DECAL	1
10	XDOZZ	81337	5-13-4758	..DECAL	1

END OF FIGURE

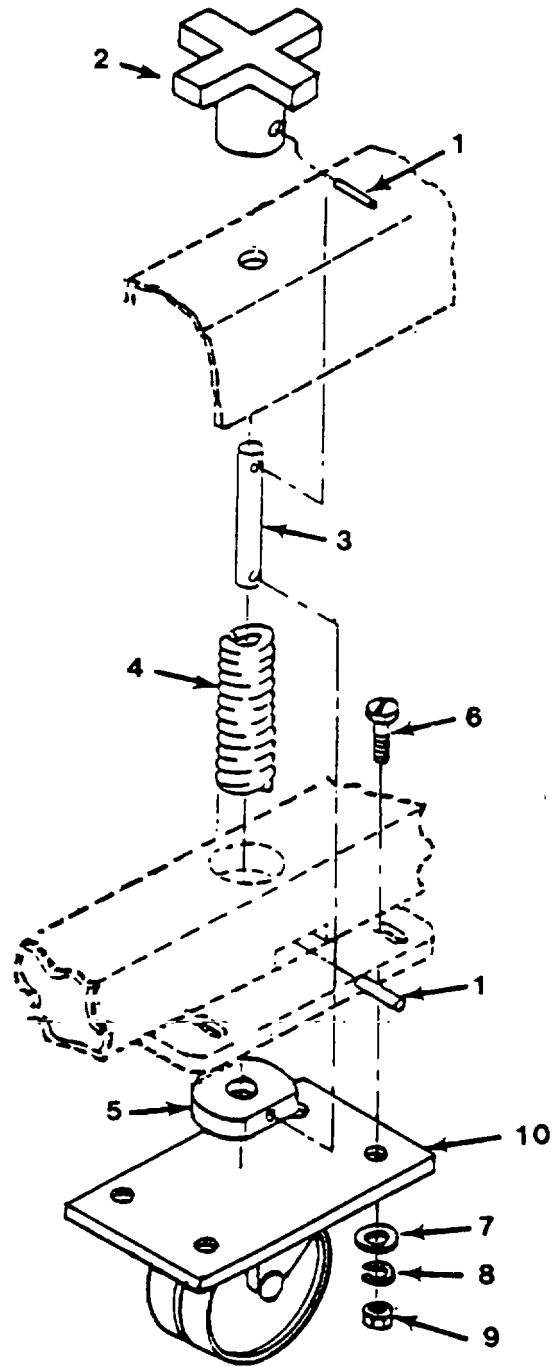

Figure 15. Transporter Wheel Assembly

F-42 Change 1

SECTION II

TM 5-3610-293-13&P

(1) ITEM NO	(2) SMR CODE	(3) CAGEC	(4) PART NUMBER	(5) DESCRIPTION AND USABLE ON CODES(UOC)	(6) QTY
-------------------	--------------------	--------------	-----------------------	---	------------

**GROUP 07 INK CART AND TOOL CADDY ASSEMBLY
FIG. 15 TRANSPORTER WHEEL ASSEMBLY**

1	XDOZZ	96906	MS16556-29	..PIN, ST	2
2	XDOZZ	81337	5-13-4715	..KNOB.....	1
3	XDOZZ	81337	5-13-4716	..STUD	1
4	PAOZZ	39428	9620K24	..SPRING, HELICAL, COMP	3
5	XDOZZ	81337	5-13-4708	..WASHER, GUIDE	1
6	XDOZZ	96906	MS51849-95	..SCREW, MACHINE.....	12
7	XDOZZ	96906	MS15795-410	..WASHER, FLAT.....	12
8	XDOZZ	96906	MS35338-44	..WASHER, LOCK.....	12
9	XDOZZ	96906	MS35649-2252	..NUT, PLAIN, HEXAGON	12
10	XDOZZ	25472	13-40-XKN	..CASTER, PIANO.....	3

END OF FIGURE

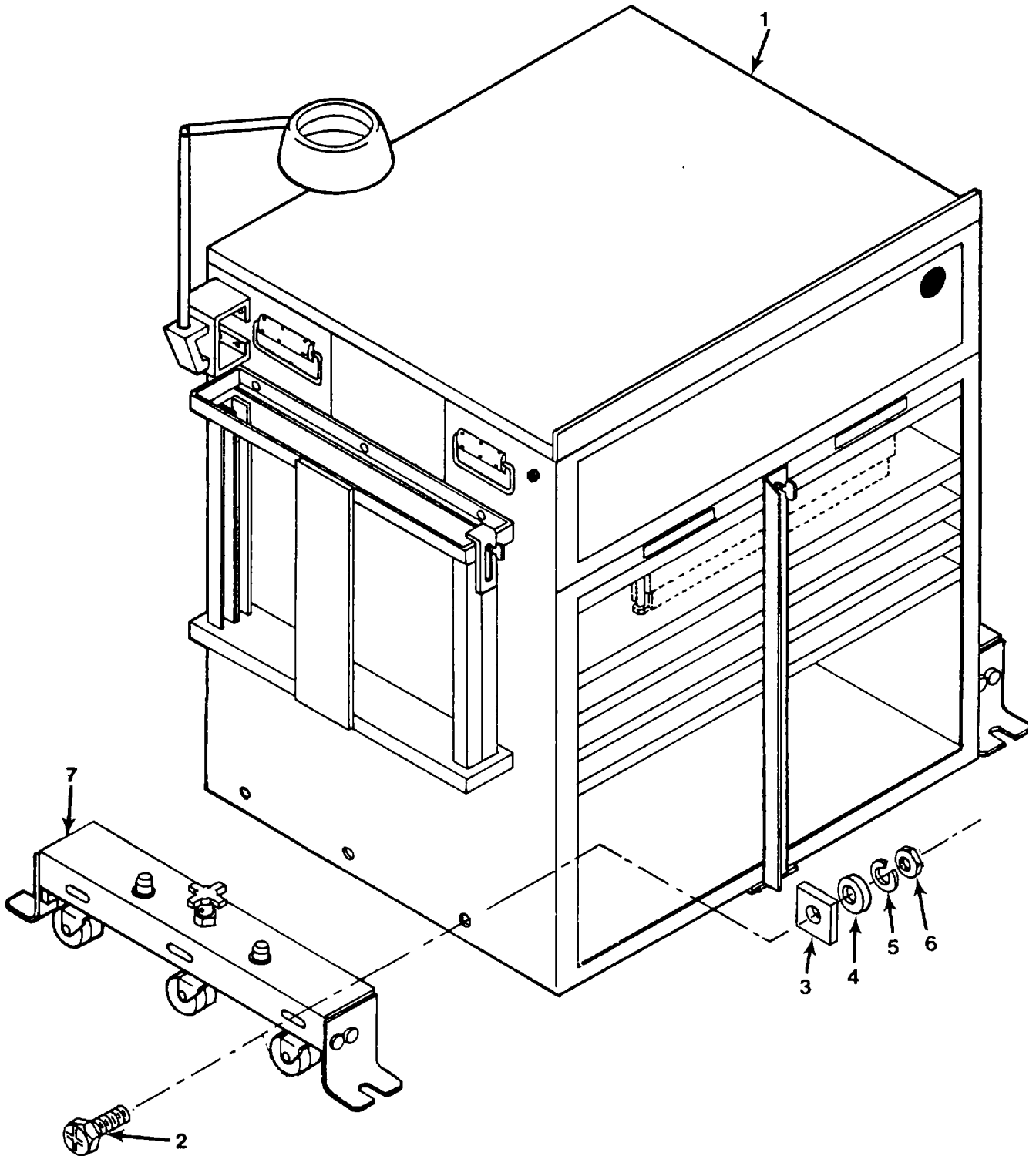

Figure 16. GTO Cabinet Assembly

SECTION II

TM 5-3610-293-13&P

(1) ITEM NO	(2) SMR CODE	(3) CAGEC	(4) PART NUMBER	(5) DESCRIPTION AND USABLE ON CODES(UOC)	(6) QTY
GROUP 08 GTO CABINET ASSEMBLY					
FIG. 16 GTO CABINET ASSEMBLY					
	PDODD	81337	5-13-4826	CABINET,STORAGE	1
1	XDODD	81337	5-13-4746	.GTO CABINET	1
2	XDOZZ	96906	MS90728-8	.SCREW,CAP,HEXAGON H.....	12
3	XDOZZ	81337	5-13-4760	.BRACKET	12
4	XDOZZ	96906	MS15795-410	.WASHER,FLAT.....	12
5	XDOZZ	96906	MS35338-44	.WASHER,LOCK.....	12
6	XDOZZ	96906	MS35649-2252	.NUT,PLAIN,HEXAGON UNC-2B.....	12
7	XDOOO	81337	5-13-4703-4	.TRANSPORTER ASSY	2

END OF FIGURE

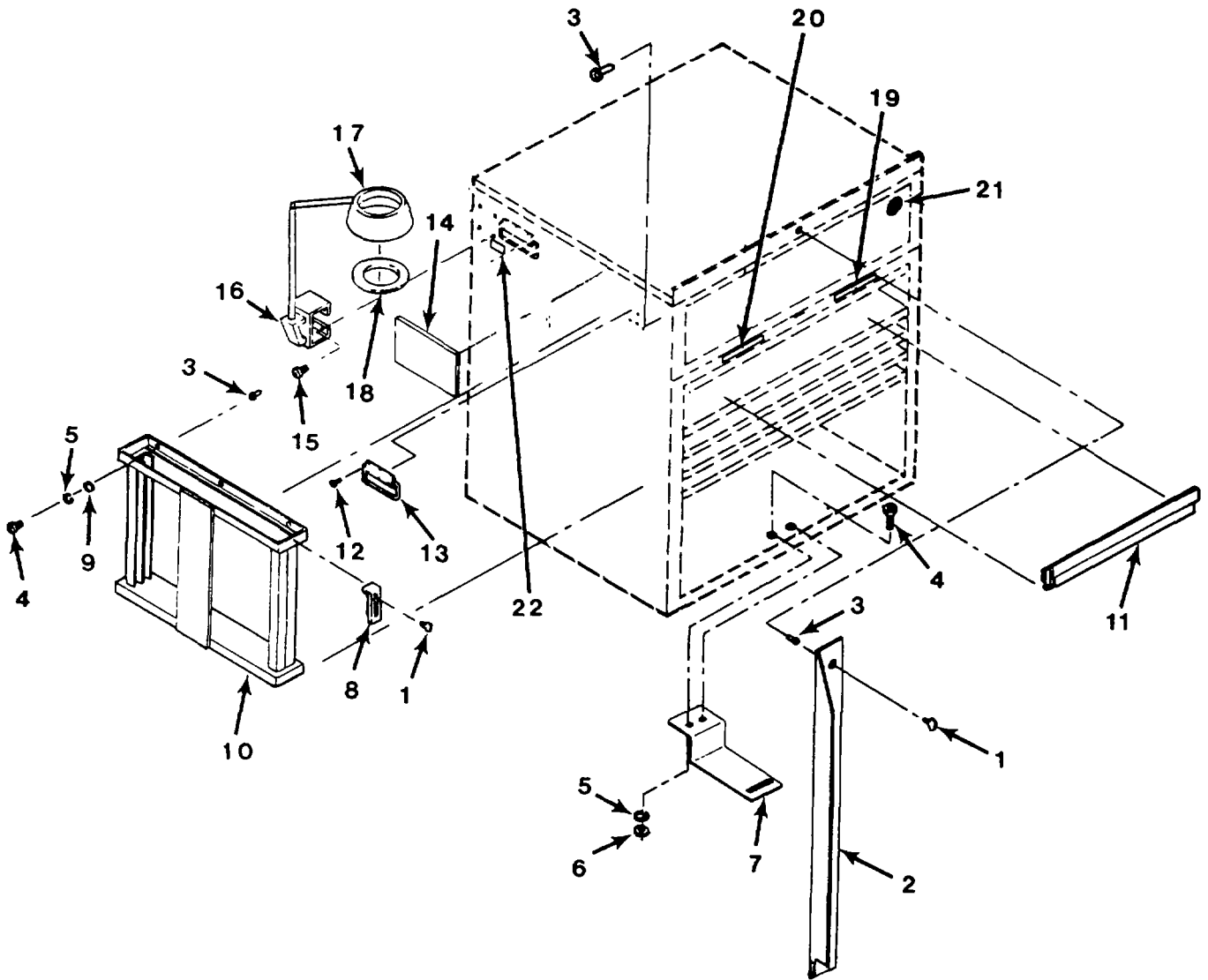

Figure 17. GTO Cabinet Modifications

SECTION II

TM 5-3610-293-13&P

(1) ITEM NO	(2) SMR CODE	(3) CAGEC	(4) PART NUMBER	(5) DESCRIPTION AND USABLE ON CODES(UOC)	(6) QTY
GROUP 08 GTO CABINET ASSEMBLY					
FIG. 17 GTO CABINET MODIFICATIONS					
	XCDDD	81337	5-13-4834	..GTO CABINET MODS	1
1	XDOZZ	96906	MS21316-35	..THUMBSCREW	1
2	XDOZZ	97403	13226E7961	..BAR,LOCKING.....	1
3	XDOZZ	96906	MS27130-A3	..NUT,RIVET	8
4	XDOZZ	96906	MS90725-6	..SCREW,CAP,HEXAGON H.....	8
5	XDOZZ	96906	MS35338-44	..WASHER,LOCK.....	8
6	XDOZZ	96906	MS35649-2252	..NUT,PLAIN,HEXAGON UNC-2B	2
7	XDOZZ	97403	13226E7965	..BRACKET,DRAWER.....	1
8	XDOZZ	81337	5-13-4750	..BRACKET,LOCK.....	1
9	XDOZZ	96906	MS15795-410	..WASHER,FLAT.....	6
10	XDOZZ	81337	5-13-4747	..HOLDER,WELDMENT FEED BOARD	1
11	XDOOO	81337	5-13-4752	..ASSY,ROLLER RACK.....	1
12	XDOZZ	96906	MS20600-MP4W6	..RIVET,BLIND	24
13	XDOZZ	98003	H5371BA	..HANDLE	4
14	XDOZZ	81337	5-13-4746-15	..SHEET,RUBBER 9.00 X 6.00 X .5 THK.....	1
15	XDOZZ	96906	MS51861-65	..SCREW,SELF-TAPPING	4
16	XDOOO	81337	5-13-4756	..ASSY,LIGHT & MTG	1
17	PBOOZ	15607	LFMA5GY	..MAGNIFIER LAMP	1
18	PAOZZ	08108	FC8T9/CW	...LAMP,FLUORESCENT CIRCULAR.....	1
19	XDOZZ	81337	5-13-4833	..DECAL	1
20	XDOZZ	81337	5-13-4757	..DECAL	1
21	XDOZZ	81337	5-13-4832-16	..STENCIL,2.0 DOT RED	1
22	XDOZZ	81337	5-13-4761	..DECAL	1

END OF FIGURE

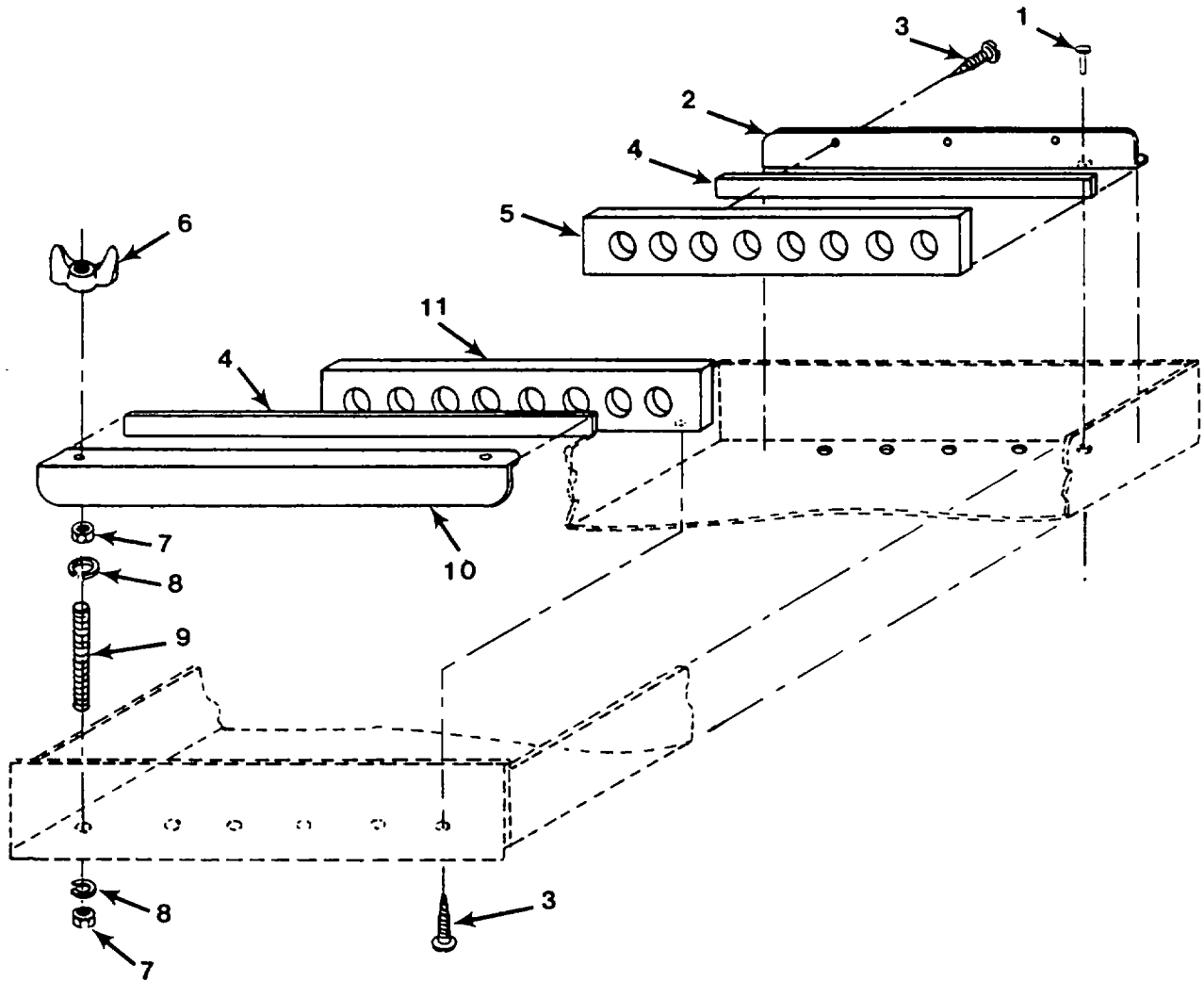

Figure 18. Roller Rack Assembly

SECTION II

TM 5-3610-293-13&P

(1) ITEM NO	(2) SMR CODE	(3) CAGEC	(4) PART NUMBER	(5) DESCRIPTION AND USABLE ON CODES(UOC)	(6) QTY
GROUP 08 GTO CABINET ASSEMBLY					
FIG. 18 ROLLER RACK ASSEMBLY					
1	XDOZZ	96906	MS20600-B6W6	...RIVET,BLIND	5
2	XDOZZ	81337	5-13-4755	...BRACKET,SUPPORT	1
3	XDOZZ	96906	MS51861-37	...SCREW,TAPPING,THREA FORMING,	7
				TYPE AB	
4	XDOZZ	81349	M6855/1-023211	...SHEET,RUBBER .25 THK X 1 X 19.25.....	2
5	XDOZZ	81337	5-13-4753-1	...SUPPORT,ROLLER	1
6	XDOZZ	96906	MS35425-70	...NUT, PLAIN, WING	2
7	XDOZZ	96906	MS35649-2252	...NUT,PLAIN,HEXAGON	4
8	XDOZZ	96906	MS35338-139	...WASHIER,LOCK.....	4
9	XDOZZ	96906	MS16187-11	...STUD,CONT THRD.....	2
10	XDOZZ	81337	5-13-4754	...BRACKET, SUPPORT, TOP	1
11	XDOZZ	81337	5-13-4753-2	...SUPPORT,ROLLER.....	1

END OF FIGURE

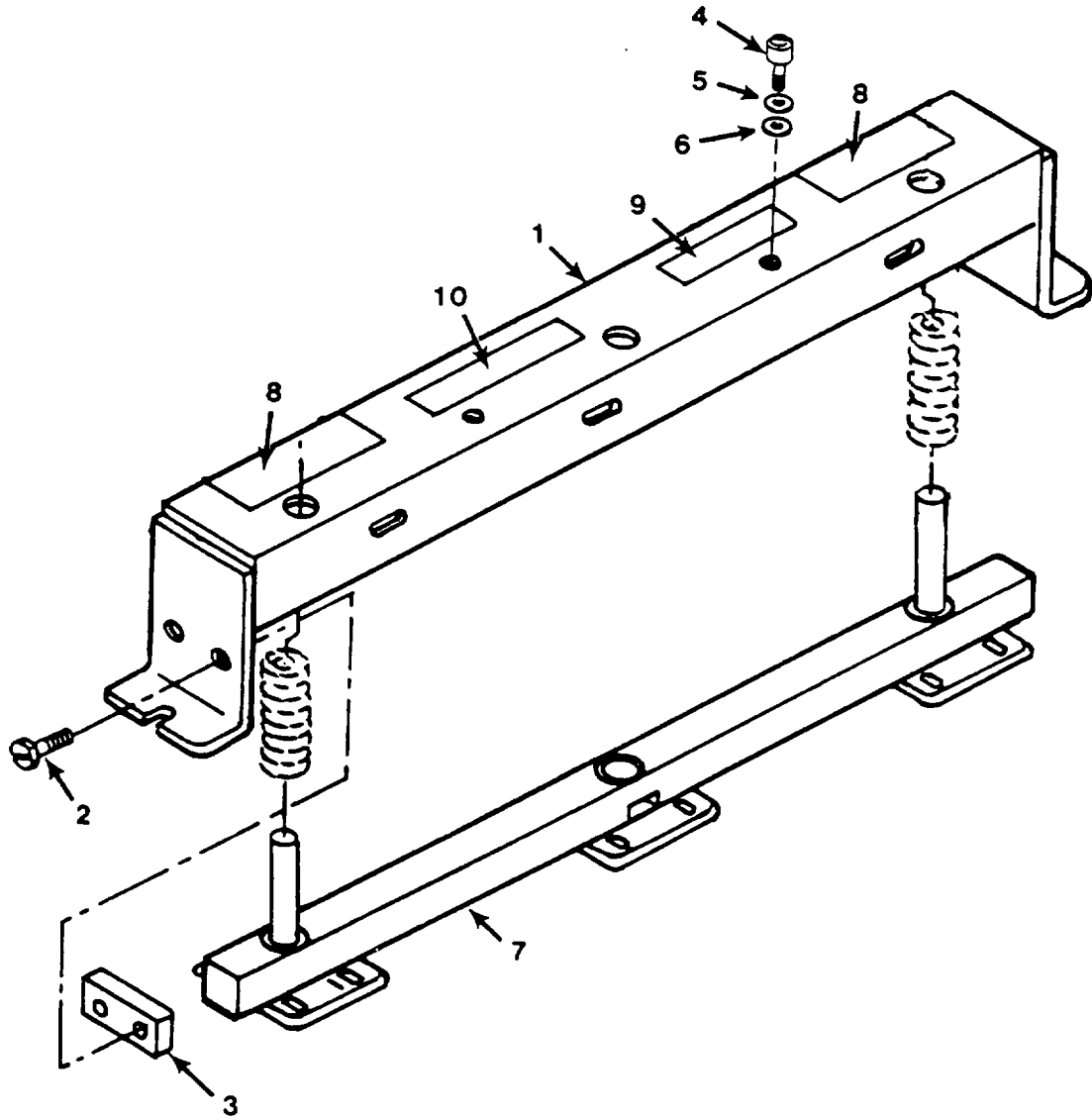

Figure 19. Transporter Assembly

SECTION II

TM 5-3610-293-13&P

(1) ITEM NO	(2) SMR CODE	(3) CAGEC	(4) PART NUMBER	(5) DESCRIPTION AND USABLE ON CODES(UOC)	(6) QTY
GROUP 08 GTO CABINET ASSEMBLY					
FIG. 19 TRANSPORTER ASSEMBLY					
1	XDOZZ	81337	5-13-4704-4	..HSING,TRANSPORTER	1
2	XDOZZ	96906	MS51095-303	..SCREW,HEX CAD PLATED,.50 LG.....	4
3	XDDZZ	81337	5-13-4711	..STOP,CASTER BAR.....	2
4	XDOZZ	96906	MS16998-74	..SCREW,CAP,SOCKET HE	2
5	XDOZZ	96906	MS15795-417	..WASHER,FLAT.....	2
6	XDOZZ	96906	MS15795-414	..WASHER,FLAT.....	2
7	XDOZZ	81337	5-13-4705-4	..BAR,CASTER	1
8	XDOZZ	81337	5-13-4712	..DECAL	2
9	XDOZZ	81337	5-13-4759	..DECAL	1
10	XDOZZ	81337	5-13-4758	..DECAL	1

END OF FIGURE

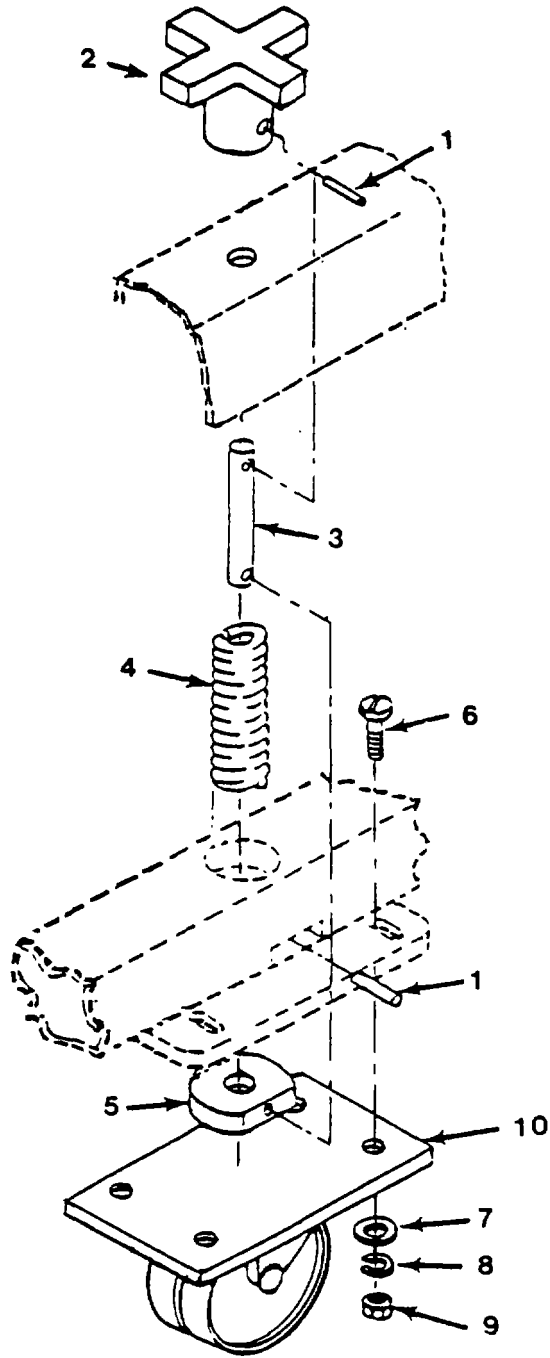

Figure 20. Transporter Wheel Assembly

Change 1 F-52

SECTION II

TM 5-3610-293-13&P

(1) ITEM NO	(2) SMR CODE	(3) CAGEC	(4) PART NUMBER	(5) DESCRIPTION AND USABLE ON CODES(UOC)	(6) QTY
GROUP 08 GTO CABINET ASSEMBLY					
FIG. 20 TRANSPORTER WHEEL ASSEMBLY					
1	XDOZZ	96906	MS16556-29	..PIN,ST	2
2	XDOZZ	81337	5-13-4715	..KNOB	1
3	XDOZZ	81337	5-13-4716	..STUD	1
4	PAOZZ	39428	9620K24	..SPRING,HELICAL,COMP	3
5	XDOZZ	81337	5-13-4708	..WASHER,GUIDE	1
6	XDOZZ	96906	MS51849-95	..SCREW,MACHINE SLOTTED, 62 LG	12
7	XDOZZ	96906	MS15795-410	..WASHER,FLAT.....	12
8	XDOZZ	96906	MS35338-44	..WASHER,LOCK.....	12
9	XDOZZ	96906	MS35649-2252	..NUT,PLAIN,HEXAGON UNC-2B	12
10	XDOZZ	25472	13-40-XKN	..CASTER,PIANO.....	3

END OF FIGURE

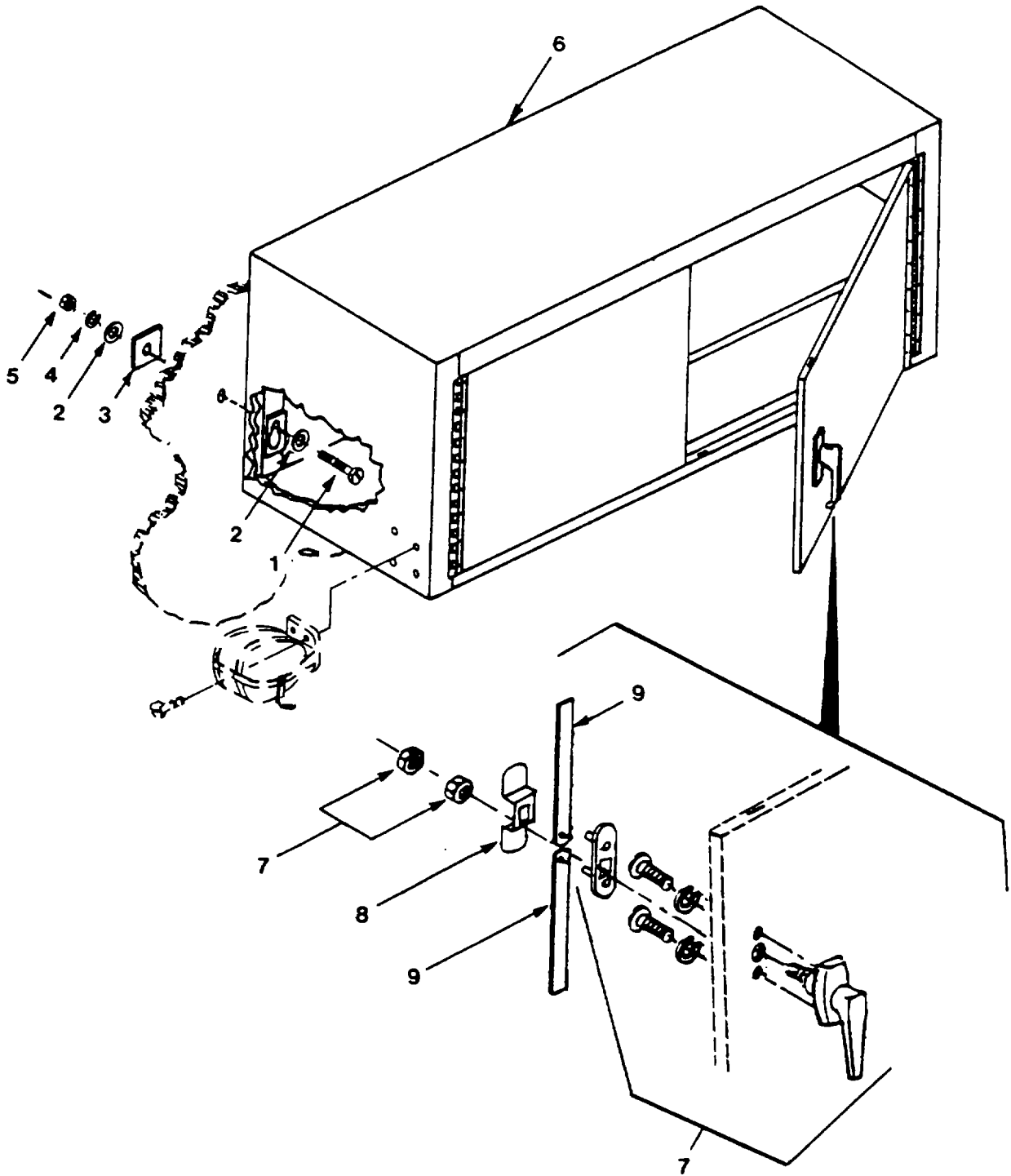

Figure 21. Wall Cabinet Assembly

Change 1 F-54

SECTION II

TM 5-3610-293-13&P

(1) ITEM NO	(2) SMR CODE	(3) CAGEC	(4) PART NUMBER	(5) DESCRIPTION AND USABLE ON CODES(UOC)	(6) QTY
				GROUP 09 STORAGE CABINET, WALL MOUNTED	
				FIG. 21 WALL CABINET ASSEMBLY	
1	XDOZZ	96906	MS90725-17	SCREW,CAP HEX HD	12
2	XDOZZ	96906	MS27183-10	WASHER,FLAT.....	24
3	XDOZZ	81337	6-1-7547-6	PLATE,WASHER,EXT	12
4	XDOZZ	96906	MS35338-44	WASHER,LOCK.....	12
5	XDOZZ	96906	MS35649-2252	NUT,PLAIN,HEXAGON	12
6	XDOOO	81337	6-1-7539	CABINET,STORAGE	3
7	XDOZZ	42689	68-090	.LATCH,DOOR.....	3
8	XDOZZ	42689	60-016-24TYPEF	.PLATE,LATCH	3
9	XDOZZ	81337	6-1-7503-17	.ARM,CATCH	6

END OF FIGURE

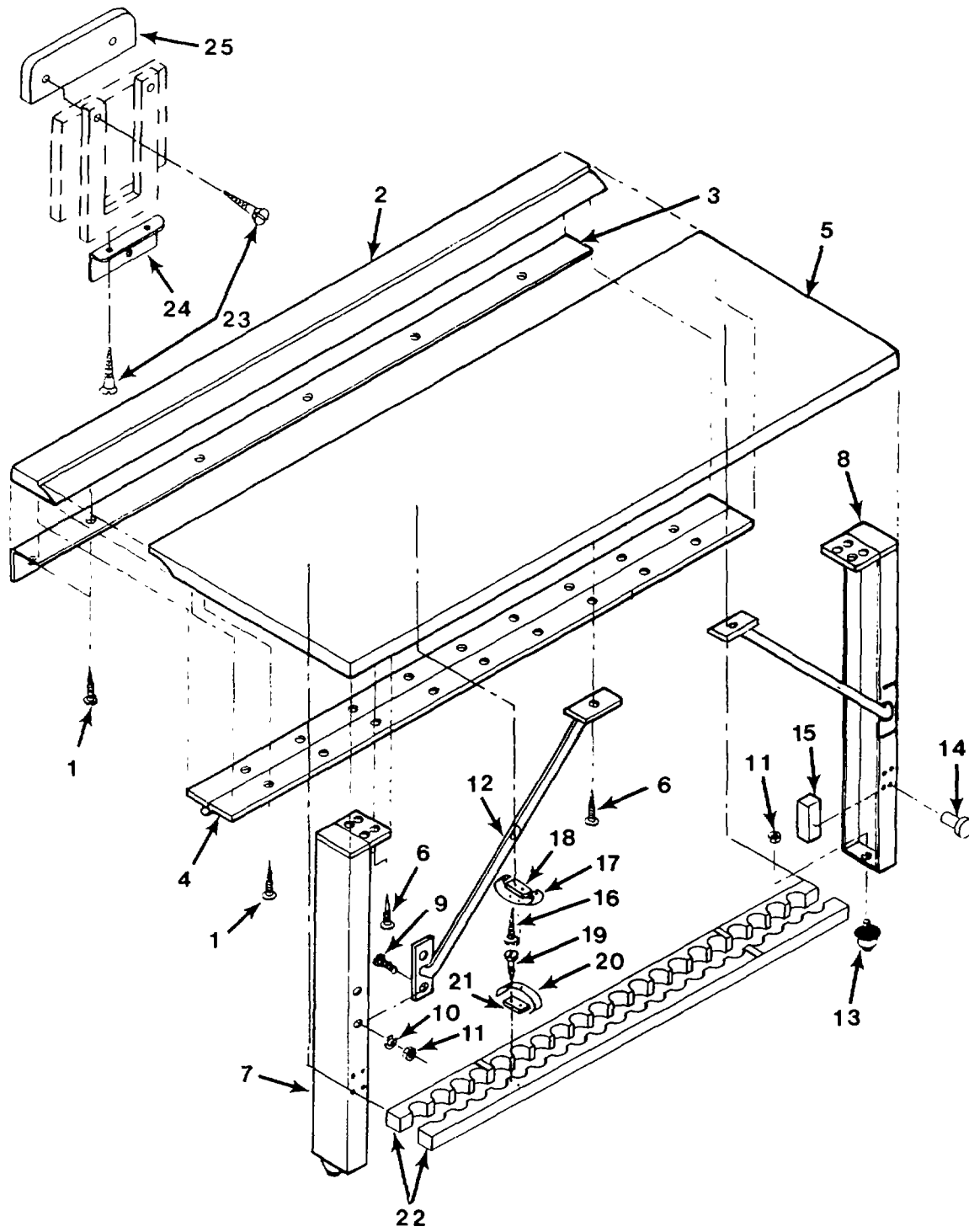

Figure 22. Folding Table Assembly

Change 1 F-56

SECTION II

TM 5-3610-293-13&P

(1) ITEM NO	(2) SMR CODE	(3) CAGEC	(4) PART NUMBER	(5) DESCRIPTION AND USABLE ON CODES(UOC)	(6) QTY
				GROUP 10 TABLE, FOLDING	
				FIG. 22 FOLDING TABLE ASSEMBLY	
	PDOOO	81337	5-13-4721	TABLE,FOLDING LEGS.....	1
1	XDOZZ	96906	MS35492-76	.SCREW,WOOD.....	29
2	XDOZZ	81337	5-13-4722	.END,TABLE TOP.....	1
3	XDDZZ	81337	5-13-4731	.SUPPORT,TABLE END.....	2
4	XDOZZ	81337	5-13-4727	.HINGE.....	1
5	XDOZZ	81337	5-13-4829	.ASSY,TABLE TOP.....	1
6	XDOZZ	96906	MS35492-78	.SCREW,WOOD.....	14
7	XDOZZ	81337	5-13-4774-1	.LEG,TABLE.....	1
8	XDOZZ	81337	5-13-4774-2	.LEG,TABLE.....	1
9	XDOZZ	96906	MS24693-S93	.SCREW.....	4
10	XDOZZ	96906	MS35338-40	.WASHER,LOCK.....	4
11	XDOZZ	96906	MS35649-2252	.NUT,PLAIN,HEXAGON.....	6
12	XDOZZ	39428	1570A11	.BRACE.....	1
13	PBOZZ	39428	2386T14	.CASTER,RIGID.....	2
14	XDOZZ	96906	MS20600-MP4W6	.RIVET,BLIND.....	8
15	PBOZZ	39428	1676A12	.CATCH,MAGNETIC.....	2
16	XDOZZ	96906	MS35492-251	.SCREW,WOOD.....	4
17	XDOZZ	81349	MIL-F-21840,TYPE II,CL1	.FASTENER,PILE.....	2
18	XDOZZ	81337	5-13-4829-6	.SHEET,ALUMM.....	2
19	XDOZZ	96906	MS35492	.SCREW,WOOD.....	8
20	XDOZZ	81349	MIL-F-71840,TYPE II,CL1	.FASTENER,HOOK.....	4
21	XDOZZ	81337	5-13-5052-2	.SHEET,ALUM.....	4
22	XDOZZ	81337	5-13-5051	.RACK,SUPPORT,ROLLER.....	1
23	XDOZZ	96906	MS35207-267	.SCREW,MACHINE.....	4
24	XDOZZ	81337	5-13-5003	.BRACKET,PUNCH.....	1
25	XDOZZ	81337	5-13-5004	.PLATE,PINCH.....	1

END OF FIGURE

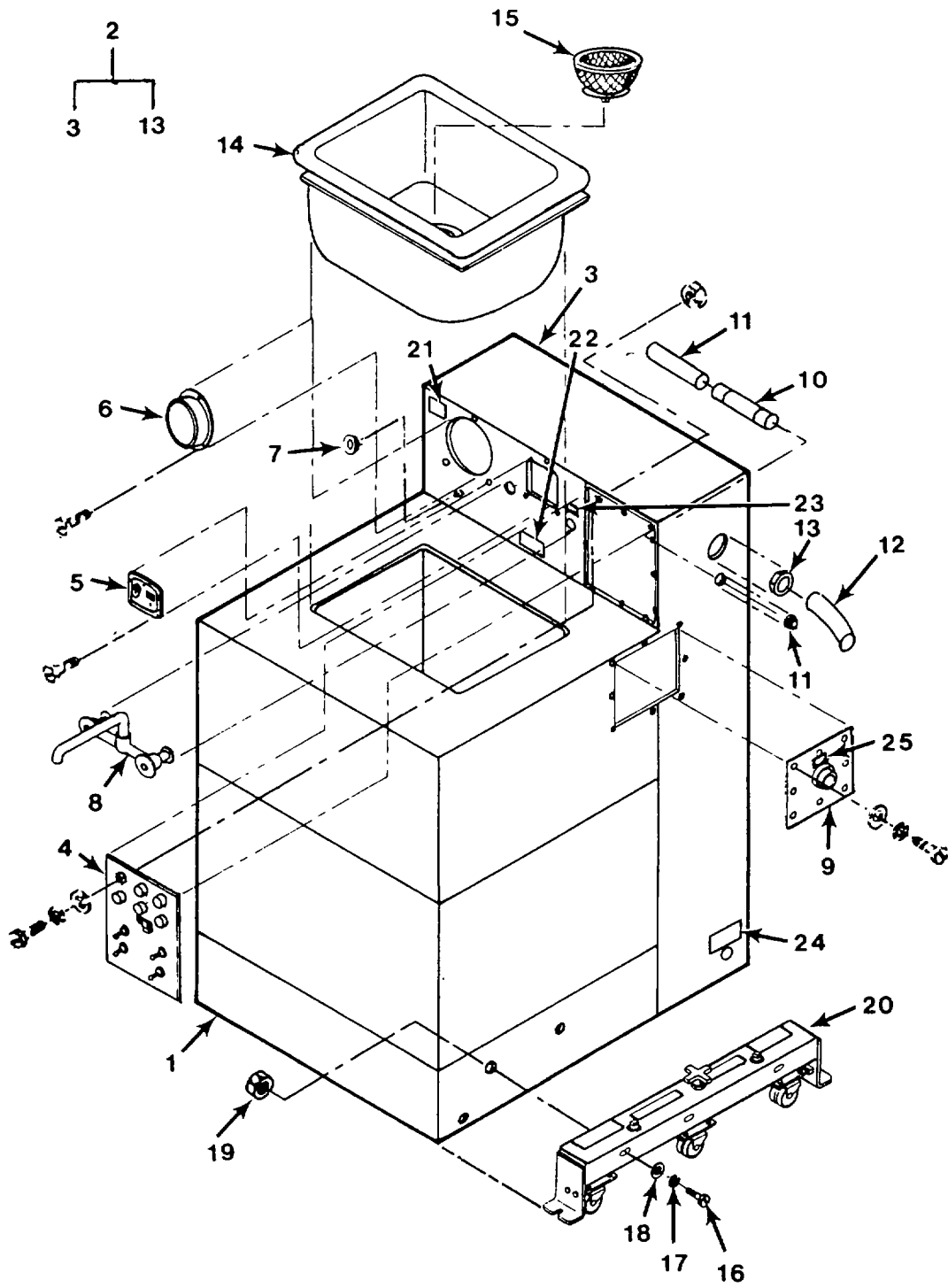

Figure 23. Sink and Transporter Assembly

Change 1 F-58

SECTION II

TM 5-3610-293-13&P

(1) ITEM NO	(2) SMR CODE	(3) CAGEC	(4) PART NUMBER	(5) DESCRIPTION AND USABLE ON CODES(UOC)	(6) QTY
GROUP 11 SINK ASSEMBLY					
FIG. 23 SINK AND TRANSPORTER ASSEMBLY					
	PBODD	81337	5-13-4942	SINK,PRINTING SYSTE	1
1	XDODD	81337	5-13-4793	.ASSY,SINK	1
2	XDODD	81337	5-13-4815	..CONTROL BOX,SINK	1
3	XAODD	81337	5-13-4812	...WELDMENT,SINK ASSY	1
4	XDOOO	81337	5-13-4941	...ASSY,CONTROL PANEL	1
5	XDOZZ	53215	PD324	...PANEL,WATER LEVEL M.....	1
6	PBOZZ	39428	4067K63	...THERMOMETER,INDICAT READINIG	1
7	XDOZZ	96906	MS35489-6	...GROMMET,NONMETALLIC	1
8	XDOZZ	58536	A-A-231	...FAUCET,DOUBLE	1
9	XDOZZ	81337	5-13-4810	...PLATE,FLOAT MTG ASS.....	1
10	PAOZZ	71400	AGC3-1/2	...FUSE,CARTRIDGE	1
11	XDOZZ	81349	M19207/16-FHN26G1	...FUSE HOLDER.....	1
12	XDOZZ	81349	J-C-58056CK3/14S RSJ	...CORD,ELECTRICAL 5.5 FT, 14-3.....	1
13	XDOZZ	28520	3219	...FITTING	1
14	XDDZZ	39428	2897K18	..SINK,SINGLE BOWL STAINLESS STEEL,..... 16 X 14 X 6.5 IN, 18 GA.....	1
15	XDDZZ	39428	2672K13	..STRAINER,SINK	1
16	XDOZZ	96906	MS90728-8	.SCREW,CAP,HEXAGON H.....	12
17	XDOZZ	96906	MS35338-44	.WASHER,LOCK.....	12
18	XDOZZ	96906	MS15795-410	.WASHER,FLAT.....	12
19	XDOZZ	96906	MS35649-2252	.NUT,PLAIN,HEXAGON	12
20	XDOOO	81337	5-13-4703-2	.TRANSPORTER ASSY	2
21	XDOZZ	81337	5-13-4797	.DECAL	1
22	XDOZZ	81337	5-13-4796	.DECAL	1
23	XDOZZ	81337	5-13-4800	.DECAL	1
24	XDOZZ	81337	5-13-4801	.DECAL	1
25	XDOZZ	81337	5-13-4799	.DECAL	1

END OF FIGURE

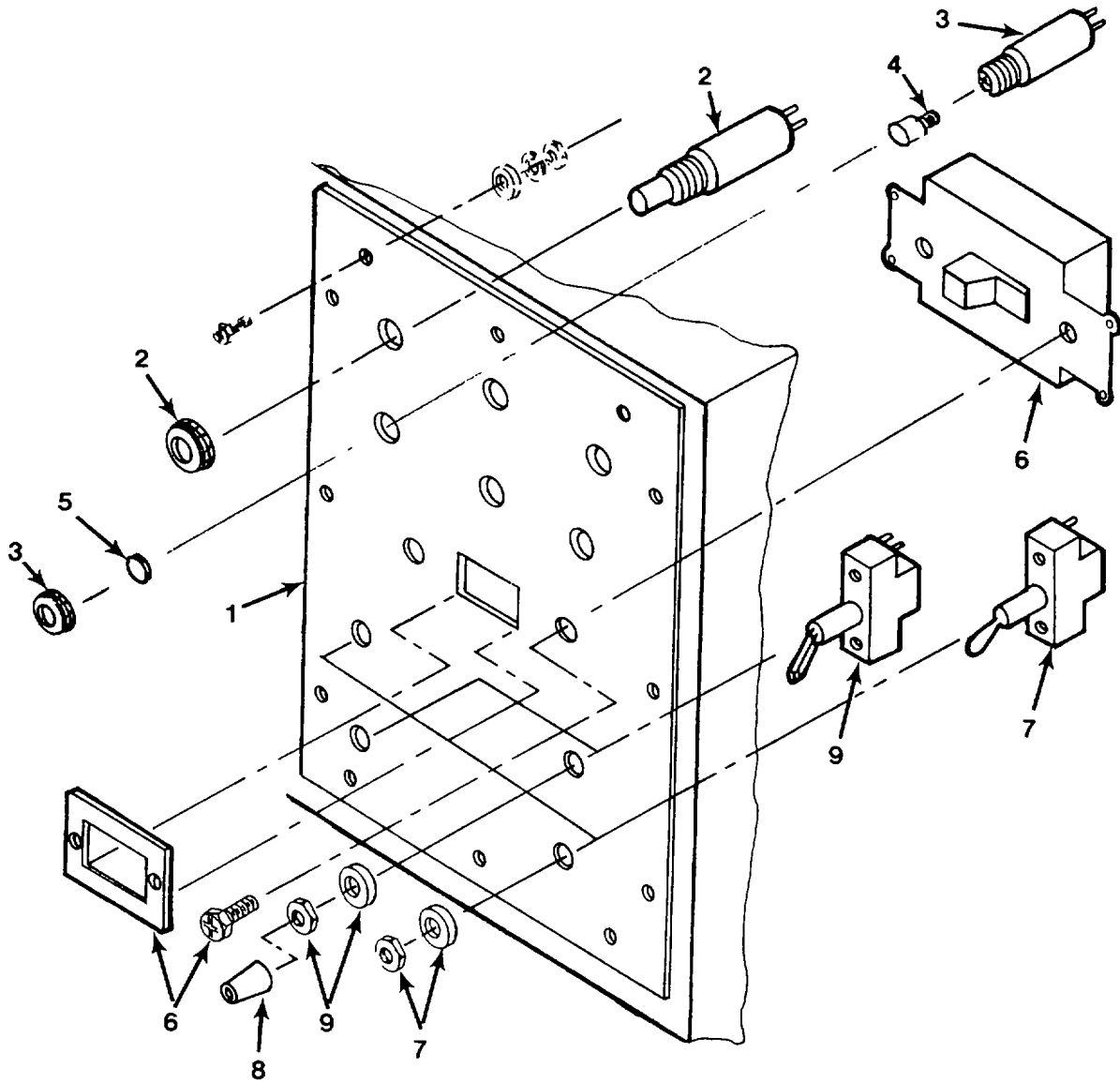

Figure 24. Control Panel Assembly

Change 1 F-60

SECTION II

TM 5-3610-293-13&P

(1) ITEM NO	(2) SMR CODE	(3) CAGEC	(4) PART NUMBER	(5) DESCRIPTION AND USABLE ON CODES(UOC)	(6) QTY
GROUP 11 SINK ASSEMBLY					
FIG. 24 CONTROL PANEL ASSEMBLY					
1	XDOZZ	81337	5-13-4921CONTROL PANEL ENGRA.....	1
2	PAOZZ	32108	20F892LAMP,INCANDESCENT 115V, T-2	3
				LAMP, WITH .375 REAR MOUNT HOLDER	
3	XDOZZ	56962	30095/SM2SOCKET,PILOT CARTRI	3
4	PAOZZ	56962	12PCLAMP,CARTRIDGE 12VOLT, 2 WATT.....	3
5	XDOZZ	56962	30149LENS,GREEN	3
6	PAOZZ	74545	1221PLSWITCH,TOGGLE	1
7	PAOZZ	96906	MS27734-22SWITCH,TOGGLE SINGLE POLE	2
8	PAOZZ	81349	M5423/02-01BOOT,DUST AND MOIST	4
9	PAOZZ	96906	MS27735-21SWITCH,TOGGLE	2

END OF FIGURE

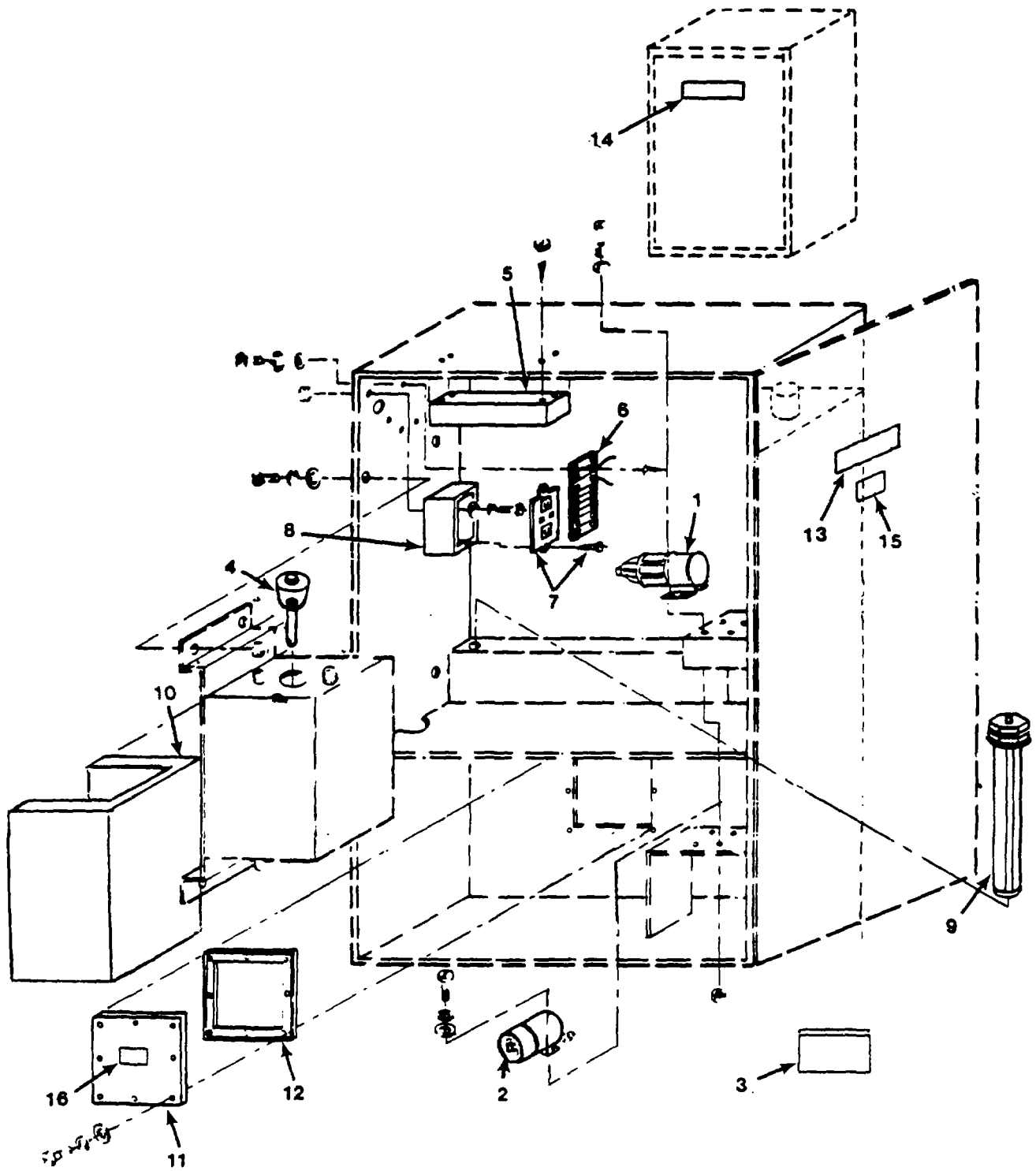

Figure 25. Sink Assembly

Change 1 F-62

SECTION II

TM 5-3610-293-13&P

(1) ITEM NO	(2) SMR CODE	(3) CAGEC	(4) PART NUMBER	(5) DESCRIPTION AND USABLE ON CODES(UOC)	(6) QTY
GROUP 11 SINK ASSEMBLY					
FIG. 25 SINK ASSEMBLY					
1	PAOZZ	66607	2088-403-444	...PUMP,COOLING SYSTEM 12VDC, 3.5 GPM, PRESSURE SWITCH OPERATED	1
2	PAOOZ	5P872	W88-959	...PUMP,CENTRIFUGAL 115V, 60 HZ	1
3	PAOZZ	5P872	W69-157	...PARTS KIT,CENTRIFUG	1
4	PAOZZ	39428	656K111	...HEATING ELEMENT,ELE 120V, 1000 WATT	1
5	PAOZZ	55814	86-12-312	...POWER SUPPLY	1
6	XDOZZ	81349	MIL-T-55164-3	...TERMINAL BOARD	1
7	XDOZZ	08556	245AL	...PLATE,WALL,ELECTRIC	1
8	PAOZZ	5P872	G22-726	...CONNECTOR,RECEPTACL GROUND	1
9	XDOZZ	53215	PD324 PROBE	FAULT INTERRUPT,115V	1
10	XDOZZ	39428	9326K5	...PROBE,WATER LEVEL	2
11	XDOZZ	81337	5-13-4806	...INSULATION,FELT 1 X 24 X 38	1
12	XDOZZ	81337	5-13-4811	...PLATE,ACCESS	1
13	XDOZZ	81337	5-13-4944	...GASKET	2
14	XDOZZ	81337	5-13-4943	...DECAL	1
15	XDOZZ	81337	5-13-4945	...DECAL	1
16	XDOZZ	81337	5-13-4973	...DECAL	1

END OF FIGURE

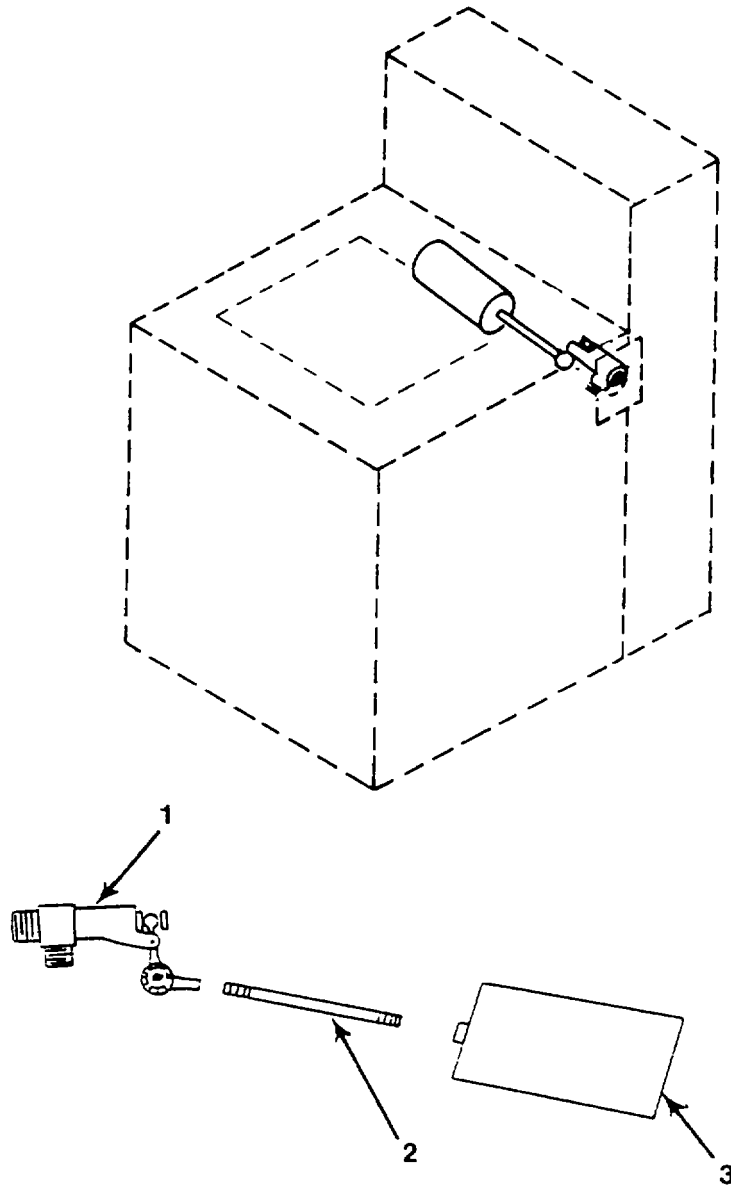

Figure 26. Float Valve Assembly

Change 1 F-64

SECTION II

TM 5-3610-293-13&P

(1) ITEM NO	(2) SMR CODE	(3) CAGEC	(4) PART NUMBER	(5) DESCRIPTION AND USABLE ON CODES(UOC)	(6) QTY
GROUP 11 SINK ASSEMBLY					
FIG. 26 FLOAT VALVE ASSEMBLY					
1	XDOZZ	39428	4652K23	...FLOAT VALVE	1
2	XDOZZ	39428	2754K1	...ROD,FLOAT BRASS, 1/4 X 8 IN	1
3	XDOZZ	39428	9775K21	...FLOAT,POLYPROPYLENE.....	1

END OF FIGURE

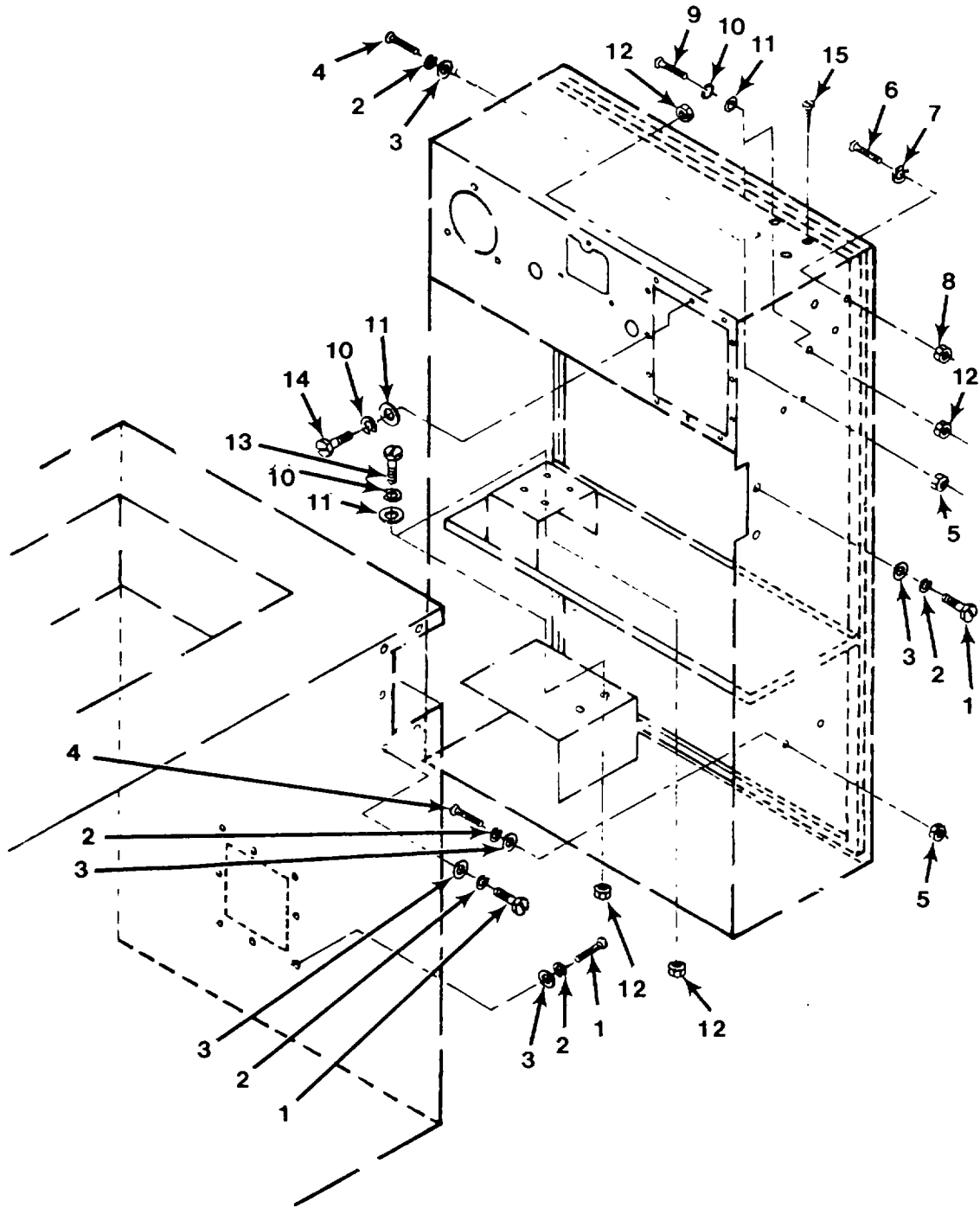

Figure 27. Sink Attaching Hardware

Change 1 F-66

SECTION II

TM 5-3610-293-13&P

(1) ITEM NO	(2) SMR CODE	(3) CAGEC	(4) PART NUMBER	(5) DESCRIPTION AND USABLE ON CODES(UOC)	(6) QTY
GROUP 11 SINK ASSEMBLY					
FIG. 27 SINK ATTACHING HARDWARE					
1	XDOZZ	96906	MS51957-80	...SCREW,MACHINE 25 CRES, .63 LG.....	16
2	XDOZZ	96906	MS35338-44	...WASHER,LOCK.....	20
3	XDOZZ	96906	MS15795-410	...WASHER,FLAT.....	20
4	XDOZZ	96906	MS51957-81	...SCREW,MACHINE PAN HD, . 25 CRES,..... .75 LG	4
5	XDOZZ	96906	MS35649-2252	...NUT,PLAIN,HEXAGON UNC-2B	4
6	XDOZZ	96906	MS51957-47	...SCREW,MACHINE #8 CRES, .75 LG.....	2
7	XDOZZ	96906	MS35338-42	...WASHER,LOCK.....	2
8	XDOZZ	96906	MS35649-282	...NUT,PLAIN,HEXAGON #8 UNC-2B	2
9	XDOZZ	96906	MS51957-64	...SCREW,MACHINE #10 CRES, .63 LG.....	2
10	XDOZZ	96906	MS35338-43	...WASHIER,LOCK.....	20
11	XDOZZ	96906	MS15795-442	...WASHIER,FLAT.....	20
12	XDOZZ	96906	MS35649-202	...NUT,PLAIN,HEXAGON #10 UNC-2B	20
13	XDOZZ	96906	MS51957-67	...SCREW,MACHINE.....	6
14	XDOZZ	96906	MS51957-63	...SCREW,MACHINE.....	12
15	XDOZZ	96906	MS51959-28	...SCREW,MACHINE.....	4

END OF FIGURE

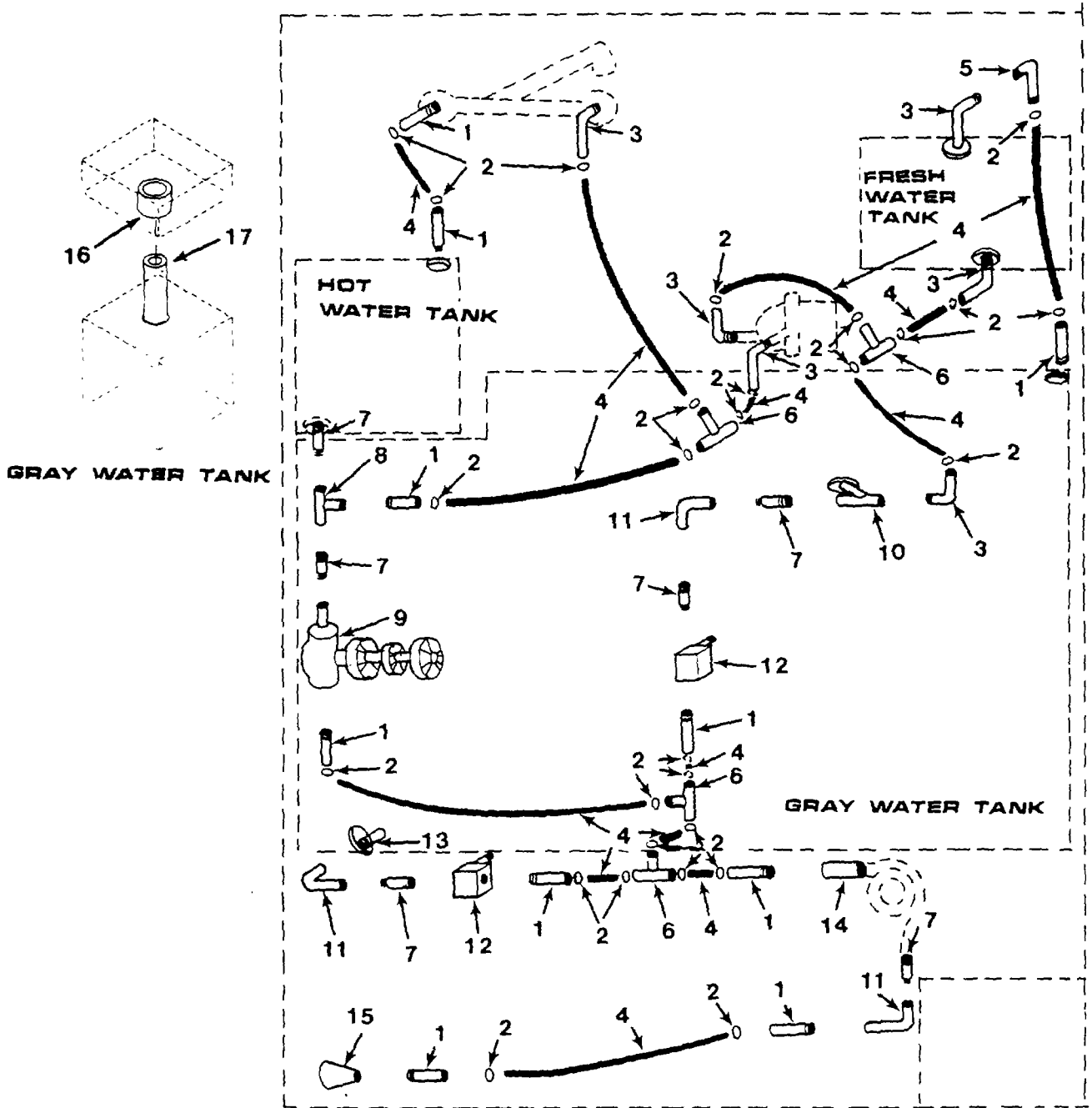

Figure 28. Sink Piping Assembly

SECTION II

TM 5-3610-293-13&P

(1) ITEM NO	(2) SMR CODE	(3) CAGEC	(4) PART NUMBER	(5) DESCRIPTION AND USABLE ON CODES(UOC)	(6) QTY
				GROUP 11 SINK ASSEMBLY	
				FIG. 28 SINK PIPING ASSEMBLY	
	XCOOO	81337	5-13-4803	..PIPING ASSY,SINK	1
1	XDOZZ	97403	13226E4442-3	...NIPPLE	10
2	XDOZZ	96906	MS35842-10	...CLAMP,HOSE	30
3	XDOZZ	39428	5373K25	...ELBOW	6
4	XDOZZ	97403	13226E4433-1	...TUBING	V
5	PBOZZ	39428	5373K73	...ELBOW,HOSE	1
6	XDOZZ	97403	13226E4550	...TEE	4
7	XDOZZ	39428	4548F171	...NIPPLE	6
8	PBOZZ	39428	4452K434	...TEE,PIPE TO HOSE	1
9	XDOZZ	63686	3058 1/2	...VALVE,GLOBE	1
10	XDOZZ	39428	4743K1	...VALVE.....	1
11	XDOZZ	39428	4819K14	...ELBOW	3
12	PAOZZ	04845	8210D2	...VALVE,SOLENOID 115V, 1/2 IN IPS.	2
13	XDOZZ	39428	4548K176	...NIPPLE	1
14	XDOZZ	39428	4823K14	...COUPLING.....	1
15	XDOZZ	39428	4832K14	...REDUCER.....	1
16	XDOZZ	39428	4823K18	...COUPLING.....	1
17	XDOZZ	39428	4813K81	...PIPE	1

END OF FIGURE

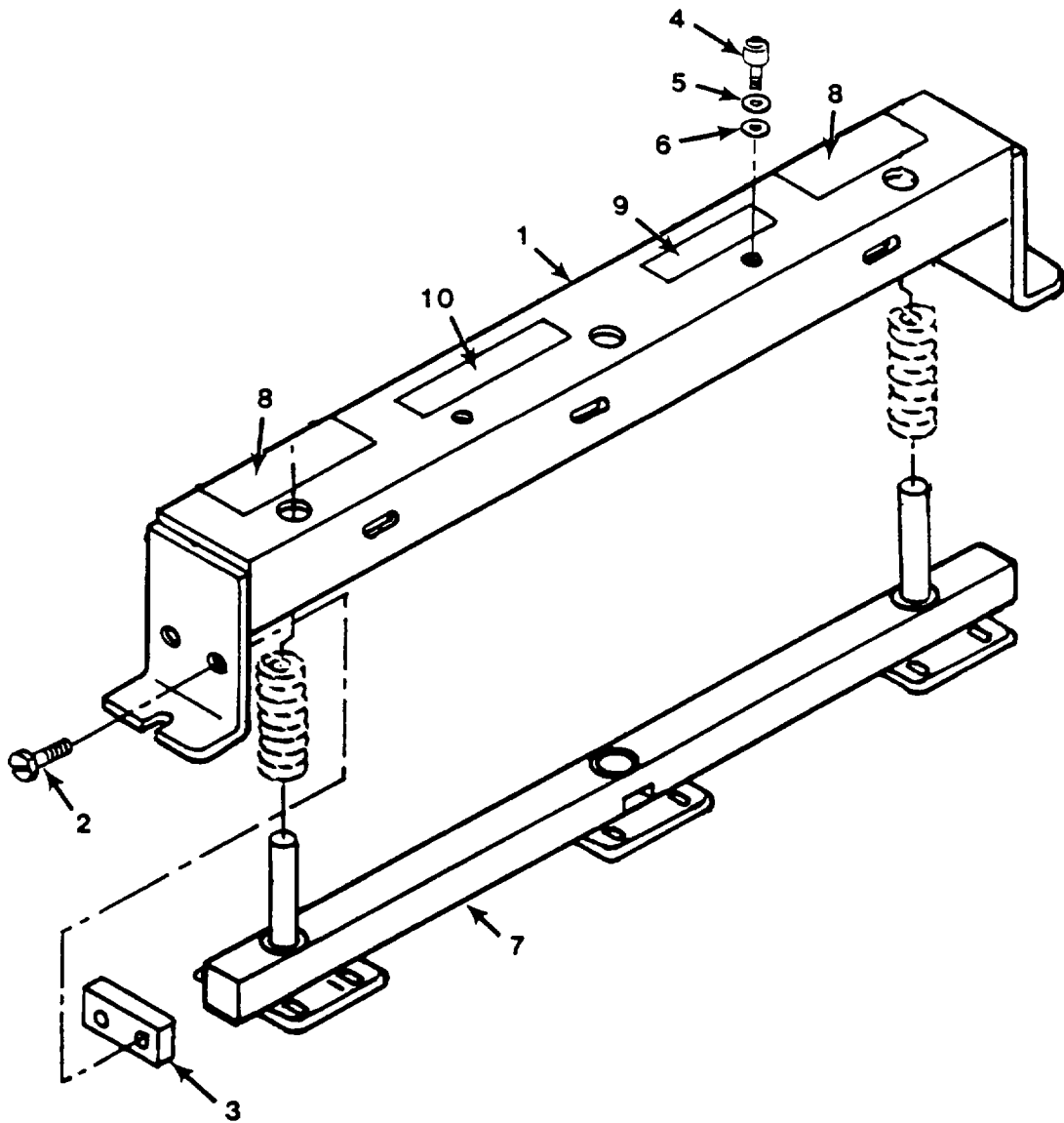

Figure 29. Transporter Assembly

Change 1 F-70

SECTION II

TM 5-3610-293-13&P

(1) ITEM NO	(2) SMR CODE	(3) CAGEC	(4) PART NUMBER	(5) DESCRIPTION AND USABLE ON CODES(UOC)	(6) QTY
GROUP 11 SINK ASSEMBLY					
FIG. 29 TRANSPORTER ASSEMBLY					
1	XDOZZ	81337	5-13-4704-5	..HSING,TRANSPORTER	1
2	XDOZZ	96906	MS51095-303	..SCREW,HEX.....	4
3	XDOZZ	81337	5-13-4711	..STOP,CASTER BAR.....	2
4	XDOZZ	96906	MS16998-74	..SCREW,CAP,SOCKET HE	2
5	XDOZZ	96906	MS15795-417	..WASHER,FLAT.....	2
6	XDOZZ	96906	MS15795-414	..WASHER,FLAT.....	2
7	XDOZZ	81337	5-13-4705-2	..BAR,CASTER	1
8	XDOZZ	81337	5-13-4712	...DECAL	2
9	XDOZZ	81337	5-13-4759	...DECAL	1
10	XDOZZ	81337	5-13-4758	...DECAL	1

END OF FIGURE

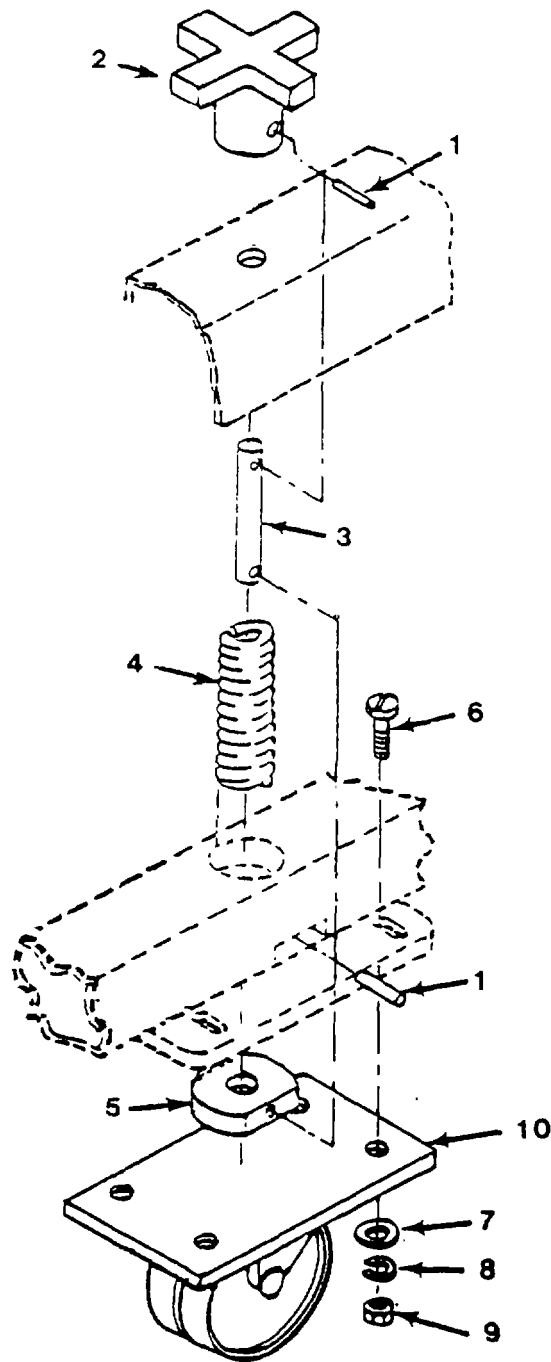

Figure 30. Transporter Wheel Assembly

Change 1 F-72

SECTION II

TM 5-3610-293-13&P

(1) ITEM NO	(2) SMR CODE	(3) CAGEC	(4) PART NUMBER	(5) DESCRIPTION AND USABLE ON CODES(UOC)	(6) QTY
GROUP 11 SINK ASSEMBLY					
FIG. 30 TRANSPORTER WHEEL ASSEMBLY					
1	XDOZZ	96906	MS16556-29	..PIN,ST	2
2	XDOZZ	81337	5-13-4715	..KNOB	1
3	XDOZZ	81337	5-13-4716	..STUD	1
4	PAOZZ	39428	9620K24	..SPRING,HELICAL,COMP	3
5	XDOZZ	81337	5-13-4708	..WASHER,GUIDE	1
6	XDOZZ	96906	MS51849-95	..SCREW,MACIINE	12
7	XDOZZ	96906	MS15795-410	..WASHER,FLAT.....	12
8	XDOZZ	96906	MS35338-44	..WASHER,LOCK.....	12
9	XDOZZ	96906	MS35649-2252	..NUT,PLAIN,HEXAGON	12
10	XDOZZ	25472	13-40-XKN	..CASTER,PIANO.....	3

END OF FIGURE

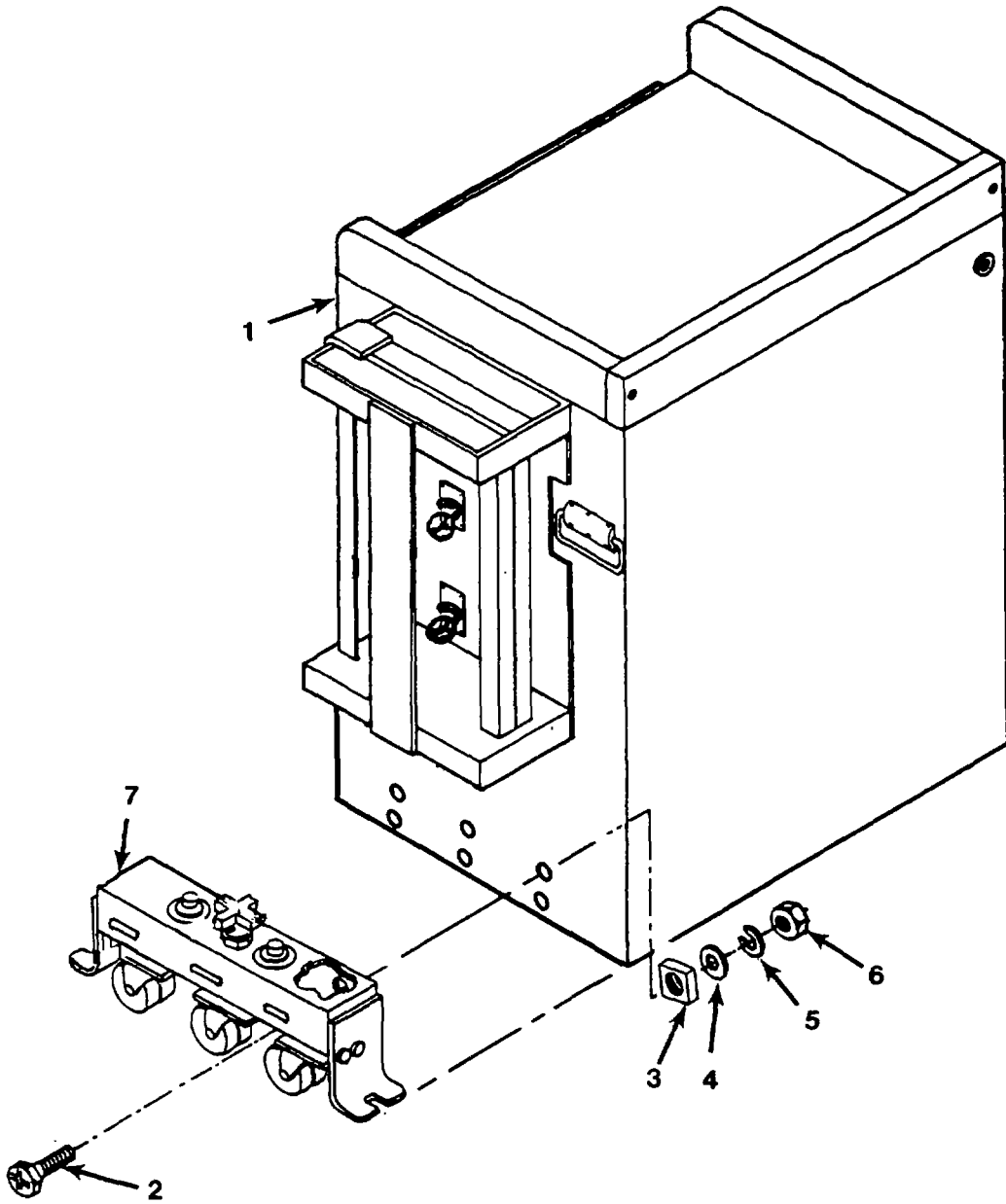

Figure 31. Paper Jogging Cabinet and Transporter Assembly

Change 1 F-74

SECTION II

TM 5-3610-293-13&P

(1) ITEM NO	(2) SMR CODE	(3) CAGEC	(4) PART NUMBER	(5) DESCRIPTION AND USABLE ON CODES(UOC)	(6) QTY
				GROUP 12 CABINET ASSEMBLY, PAPER JOGGING	
				FIG. 31 PAPER JOGGING CABINET AND TRANSPORTER ASSEMBLY	
	PBODD	81337	5-13-4828	CABINET, STORAGE	1
1	XDODD	81337	5-13-4762	.JOGGING CABINET ASS	1
2	XDOZZ	96906	MS90728-8	.SCREW, CAP, HEXAGON H.....	12
3	XDOZZ	81337	5-13-4835	.BRACKET	12
4	XDOZZ	96906	MS15795-410	.WASHER, FLAT.....	12
5	XDOZZ	96906	M535338-44	.WASHER, LOCK.....	12
6	XDOZZ	96906	M535649-2252	.NUT, PLAIN, HEXAGON UNC-2B	12
7	XDOOO	81337	5-13-4703-1	.TRANSPORTER ASSY	2
				END OF FIGURE	

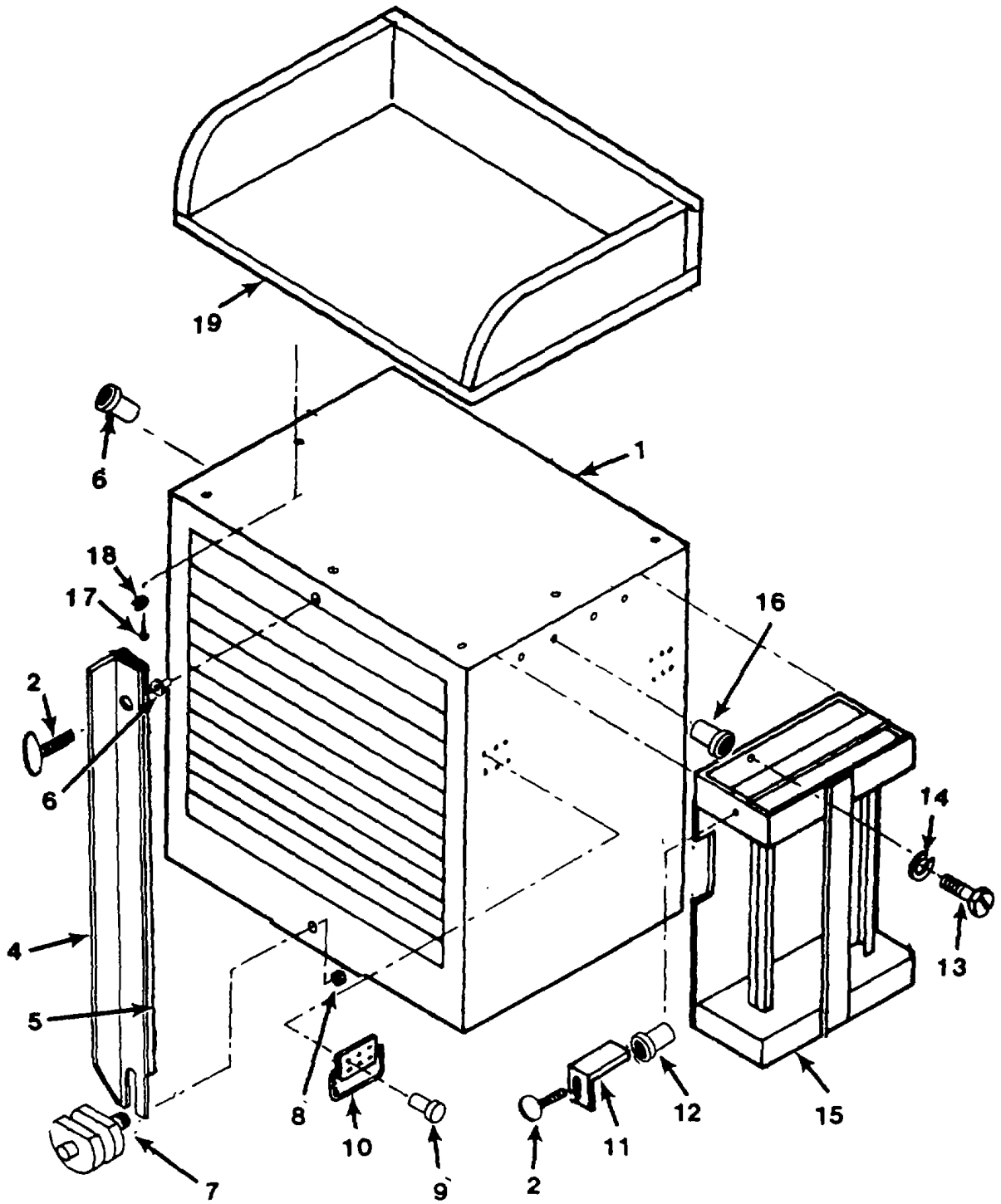
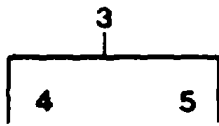

Figure 32. Paper Jogging Cabinet Assembly

Change 1 F-76

SECTION II

TM 5-3610-293-13&P

(1) ITEM NO	(2) SMR CODE	(3) CAGEC	(4) PART NUMBER	(5) DESCRIPTION AND USABLE ON CODES(UOC)	(6) QTY
GROUP 12 CABINET ASSEMBLY, PAPER JOGGING					
FIG. 32 PAPER JOGGING CABINET ASSEMBLY					
1	XADDD	2R621	627	..CABINET, 12 DWR	1
2	XDOZZ	96906	MS21316-36	..THUMBSCREW	2
3	XDOOO	81337	5-13-4827	..BRACKET, DWR ASSY	1
4	XDOZZ	81337	5-13-4768	..BRACKET, DWR	1
5	XDOZZ	81337	5-13-4827-3	..SHEET, RUBBER 1.25 X 28 X .5 THK.....	1
6	XDOZZ	96906	MS27130-A31	..NUT PLAIN BLIND, RIVET, FLAT	2
7	XDOZZ	97403	13226E4397	..BASE, CABINET DWR.....	1
8	XDOZZ	96906	MS35649-2382	..NUT, PLAIN, HEXAGON UNC-2B	1
9	XDOZZ	96906	MS20600-MP4W6	..RIVET, BLIND	24
10	XDOZZ	98003	H5371BA	..HANDLE.....	4
11	XDOZZ	81337	5-13-4773	..BRACKET, LOCKING.....	1
12	XDOZZ	96906	MS27130-A32	..NUT, RIVET	1
13	XDOZZ	96906	MS35206-263	..SCREW, MACHINE.....	8
14	XDOZZ	96906	MS35338-138	..WASHER, LOCK.....	8
15	XDOZZ	81337	5-13-4769	..ASSY, DELIVERY BRD	1
16	XDOZZ	96906	MS27130-A19	..NUT, BLIND RIVET	8
17	XDOZZ	96906	MS24617-46	..SCREW, TAP, #10X1.00.....	6
18	XDOZZ	96906	MS35338-44	..WASHER, LOCK	6
19	XDOZZ	81337	5-13-4764	..ASSY, TABLE TOP	1
END OF FIGURE					

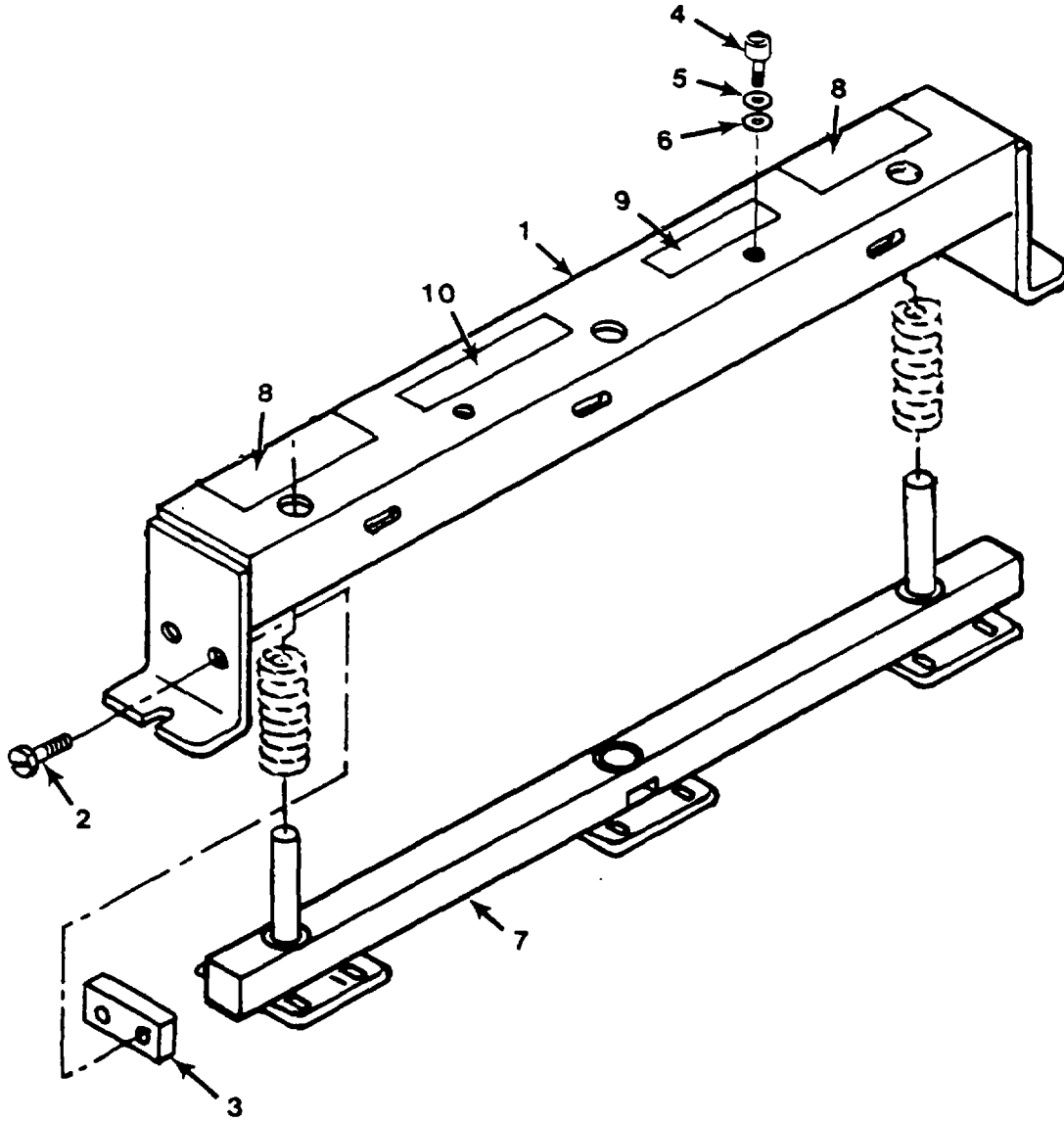

Figure 33. Transporter Assembly

SECTION II

TM 5-3610-293-13&P

(1) ITEM NO	(2) SMR CODE	(3) CAGEC	(4) PART NUMBER	(5) DESCRIPTION AND USABLE ON CODES(UOC)	(6) QTY
GROUP 12 CABINET ASSEMBLY, PAPER JOGGING					
FIG. 33 TRANSPORTER ASSEMBLY					
1	XDOZZ	81337	5-13-4704-1	..HSING, TRANSPORTER	1
2	XDOZZ	96906	MS51095-303	..SCREW, HEX.....	4
3	XDDZZ	81337	5-13-4711	..STOP, CASTER BAR.....	2
4	XDOZZ	96906	MS16998-74	..SCREW, CAP, SOCKET HE	2
5	XDOZZ	96906	MS15795-417	..WASHER, FLAT.....	2
6	XDOZZ	96906	MS15795-414	..WASHER, FLAT.....	2
7	XDOZZ	81337	5-13-4705-1	..BAR, CASTER	1
8	XDOZZ	81337	5-13-4712	...DECAL	1
9	XDOZZ	81337	5-13-4759	...DECAL	1
10	XDOZZ	81337	5-13-4758	...DECAL	1
END OF FIGURE					

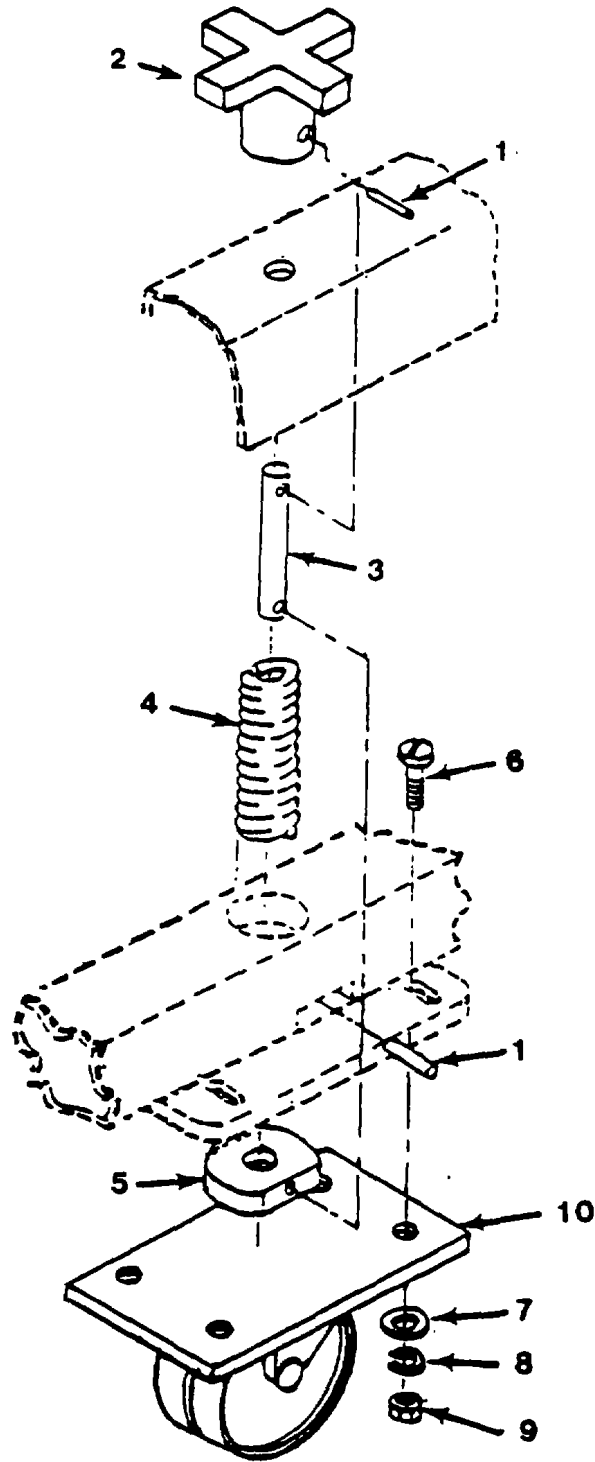

Figure 34. Transporter Wheel Assembly

Change 1 F-80

SECTION II

TM 5-3610-293-13&P

(1) ITEM NO	(2) SMR CODE	(3) CAGEC	(4) PART NUMBER	(5) DESCRIPTION AND USABLE ON CODES(UOC) GROUP 12 CABINET ASSEMBLY, PAPER JOGGING FIG. 34 TRANSPORTER WHEEL ASSEMBLY	(6) QTY
1	XDOZZ	96906	MS16556-29	..PIN, ST	2
2	XDOZZ	81337	5-13-4715	..KNOB	1
3	XDOZZ	81337	5-13-4716	..STUD	1
4	PAOZZ	39428	9620K24	..SPRING, HELICAL, COMP	3
5	XDOZZ	81337	5-13-4708	..WASHER, GUIDE	1
6	XDOZZ	96906	MS51849-95	..SCREW, MACHINE.....	12
7	XDOZZ	96906	MS15795-410	..WASHER, FLAT.....	12
8	XDOZZ	96906	MS35338-44	..WASHER, LOCK.....	12
9	XDOZZ	96906	MS35649-2252	..NUT, PLAIN, HEXAGON	12
10	XDOZZ	25472	13-40-XKN	..CASTER, PIANO.....	3
END OF FIGURE					

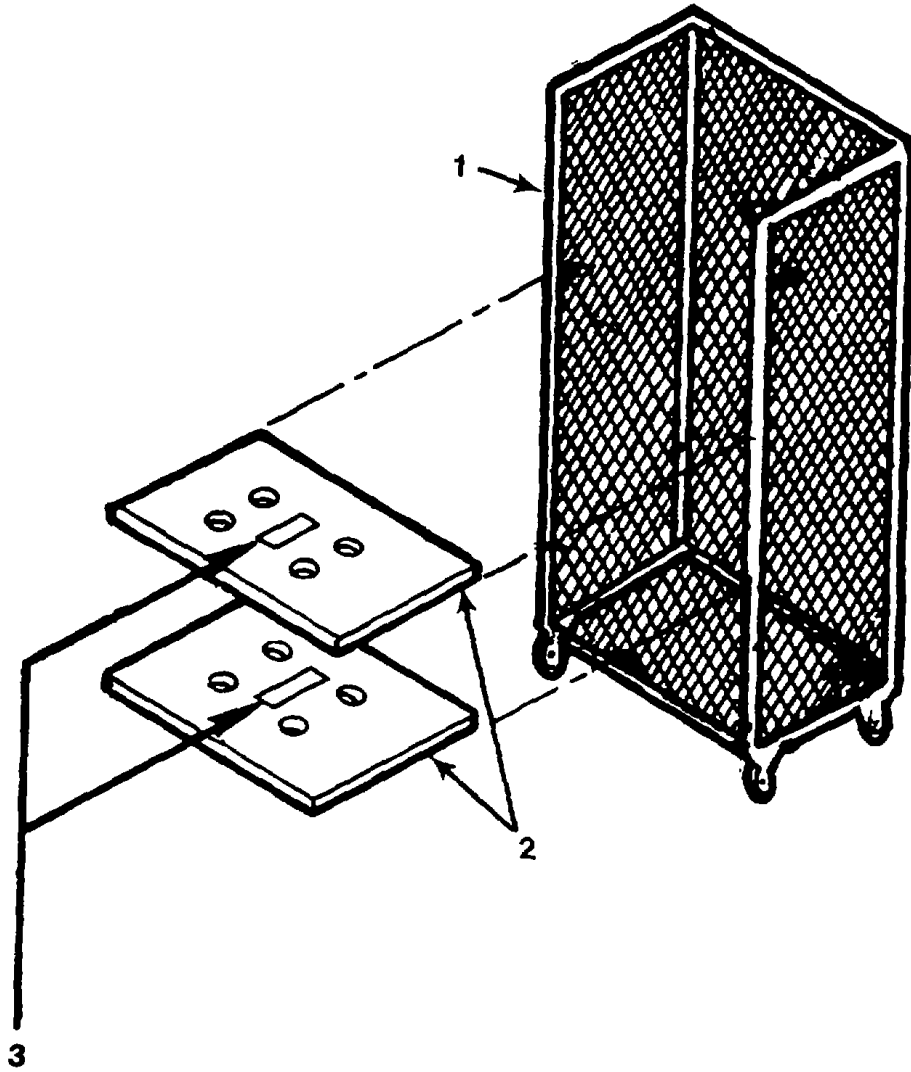

Figure 35. Work Cart Assembly

SECTION II

TM 5-3610-293-13&P

(1) ITEM NO	(2) SMR CODE	(3) CAGEC	(4) PART NUMBER	(5) DESCRIPTION AND USABLE ON CODES(UOC) GROUP 13 WORK TRANSFER CART FIG. 35 WORK CART ASSEMBLY	(6) QTY
	XDOOO	81337	5-13-5036	ASSY, WORK CART	1
1	XDOZZ	84570	1925-T1	.CART, WORK TRANSFER	1
2	XDOZZ	84570	1925-S	.SHELF.....	2
3	XDOZZ	81337	5-13-4822	.STENCIL, .5, BLACK STOOL STORAGE.....	2
				END OF FIGURE	

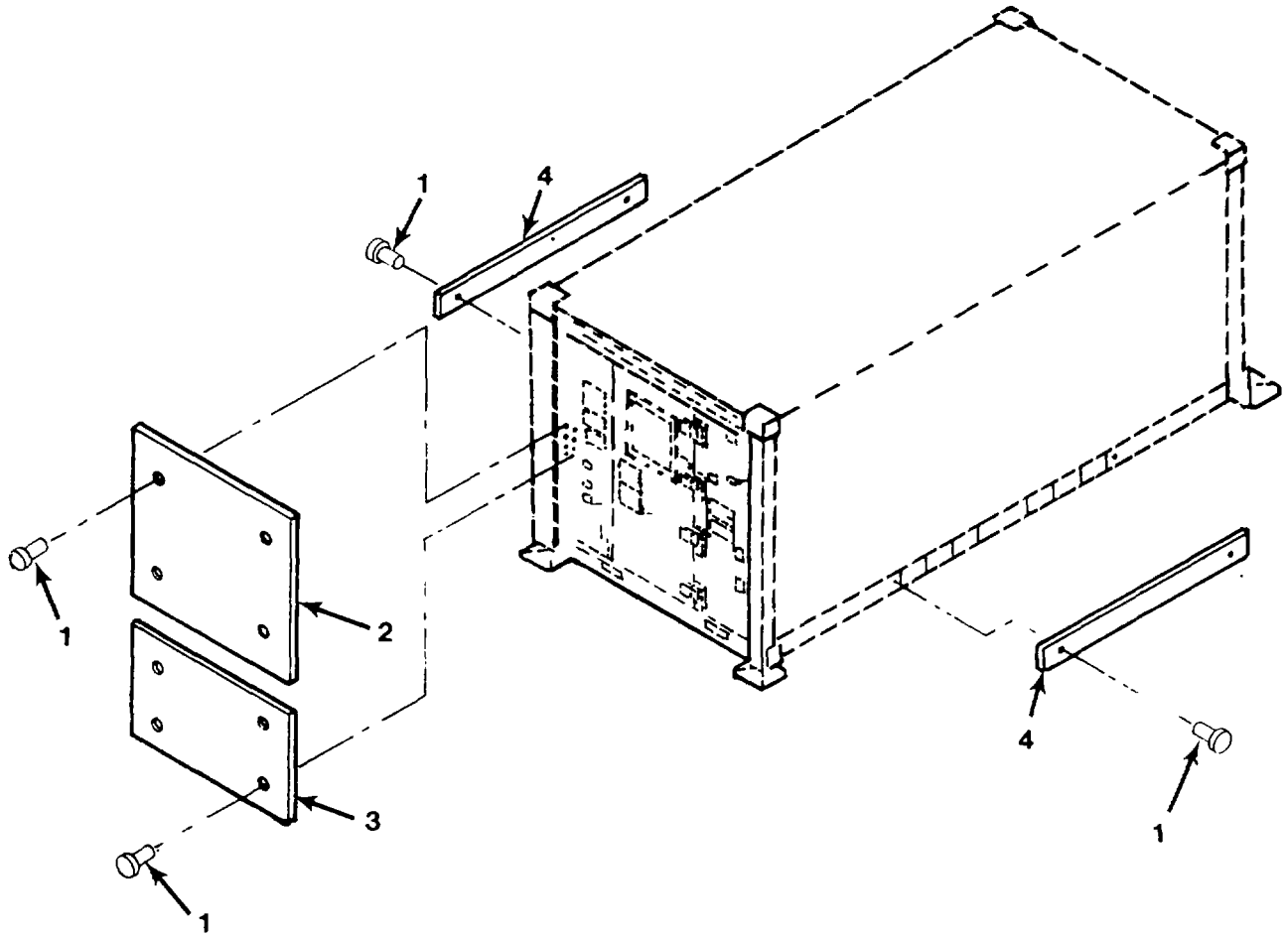

Figure 36. Outside Shelter Modifications

SECTION II

TM 5-3610-293-13&P

(1) ITEM NO	(2) SMR CODE	(3) CAGEC	(4) PART NUMBER	(5) DESCRIPTION AND USABLE ON CODES(UOC)	(6) QTY
				GROUP 15 SHELTER, ISO	
				FIG. 36 OUTSIDE SHELTER MODIFICATIONS	
	XCOZZ	81337	5-13-5024	SHELTER, OUTSIDE MOD	1
1	XDOZZ	96906	MS20604-B4T6	.RIVET, BLIND	8
2	XDOZZ	81337	5-13-5026	.DATA PLATE	1
3	XDOZZ	81337	5-13-5028	.DATA PLATE	1
4	XDOZZ	81337	5-13-5063	.PLATE, COVER	1
				END OF FIGURE	

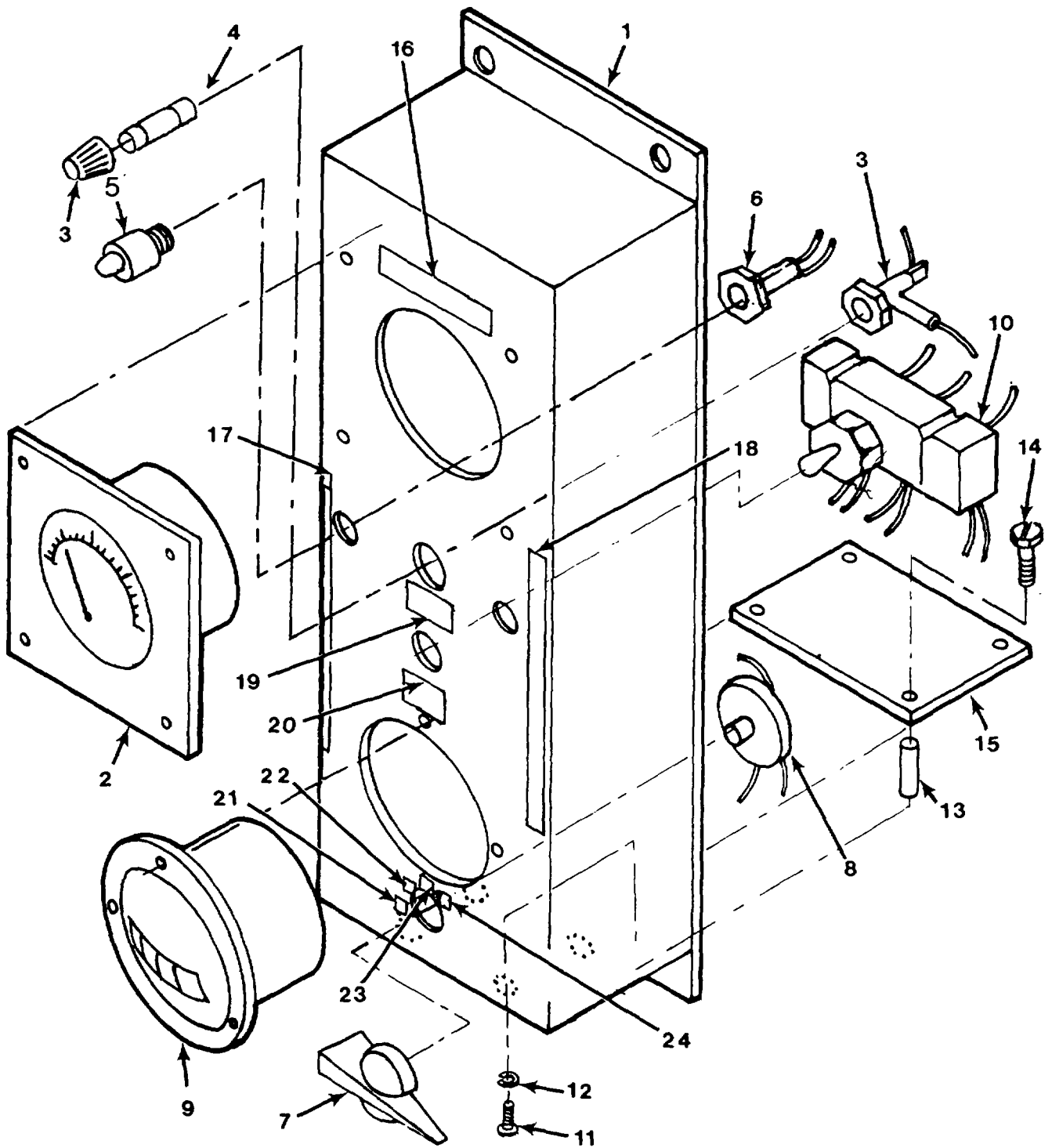

Figure 37. Phase Meter

SECTION II

TM 5-3610-293-13&P

(1) ITEM NO	(2) SMR CODE	(3) CAGEC	(4) PART NUMBER	(5) DESCRIPTION AND USABLE ON CODES(UOC)	(6) QTY
GROUP 16 PHASE MONITOR METER					
FIG. 37 PHASE METER					
	PDOOO	81337	5-13-4784	PHASEMETER.....	1
1	XDOZZ	81337	5-13-4785	.BOX, PH METER	1
2	PAOZZ	55026	10220	.VOLTMETER	1
3	XDOZZ	81349	M19207/16-FHN26G	.FUSE HOLDER.....	1
			1		
4	PAOZZ	81349	F02A250VIA	.FUSE, CARTRIDGE	1
5	PAOZZ	72619	508-8745-504	.LIGHT, INDICATOR	2
6	PAOZZ	07294	CN04WCSN114	.LAMP, CARTRIDGE.....	2
7	XDOZZ	83330	2220	.KNOB.....	1
8	PAOZZ	71590	PA1001M	.SWITCH, ROTARY	1
9	PAOZZ	31356	31FX60CPS	.FREQUENCY METER.....	1
10	PAOZZ	96906	MS27736-28	.SWITCH, TOGGLE	1
11	XDOZZ	96906	MS35206-226	.SCREW, MACHINE #6-32 X .25	4
12	XDOZZ	96906	MS35338-41	.WASHER, LOCK #6	4
13	XDOZZ	2R182	8345	.SPACER, AL, ROUND .25 X .75 LG, 6-.....	4
				32 THD THRU	
14	XDOZZ	96906	MS51959-26	.SCREW, MACHINE 82 DEG, CROSS-.....	4
				RECESSED, #6-32 X .25.....	
15	PBOZZ	97403	13225E3283	.PRINTED CIRCUIT BOA	1
16	XDOZZ	81337	5-13-4846-1	.DECAL	1
17	XDOZZ	81337	5-13-4846-2	.DECAL	1
18	XDOZZ	81337	5-13-4846-3	.DECAL	1
19	XDOZZ	81337	5-13-4846-4	.DECAL	1
20	XDOZZ	81337	5-13-4846-5	.DECAL	1
21	XDOZZ	81337	5-13-4846-6	.DECAL	1
22	XDOZZ	81337	5-13-4846-7	.DECAL	1
23	XDOZZ	81337	5-13-4846-8	.DECAL	1
24	XDOZZ	81337	5-13-4846-9	.DECAL	1
END OF FIGURE					

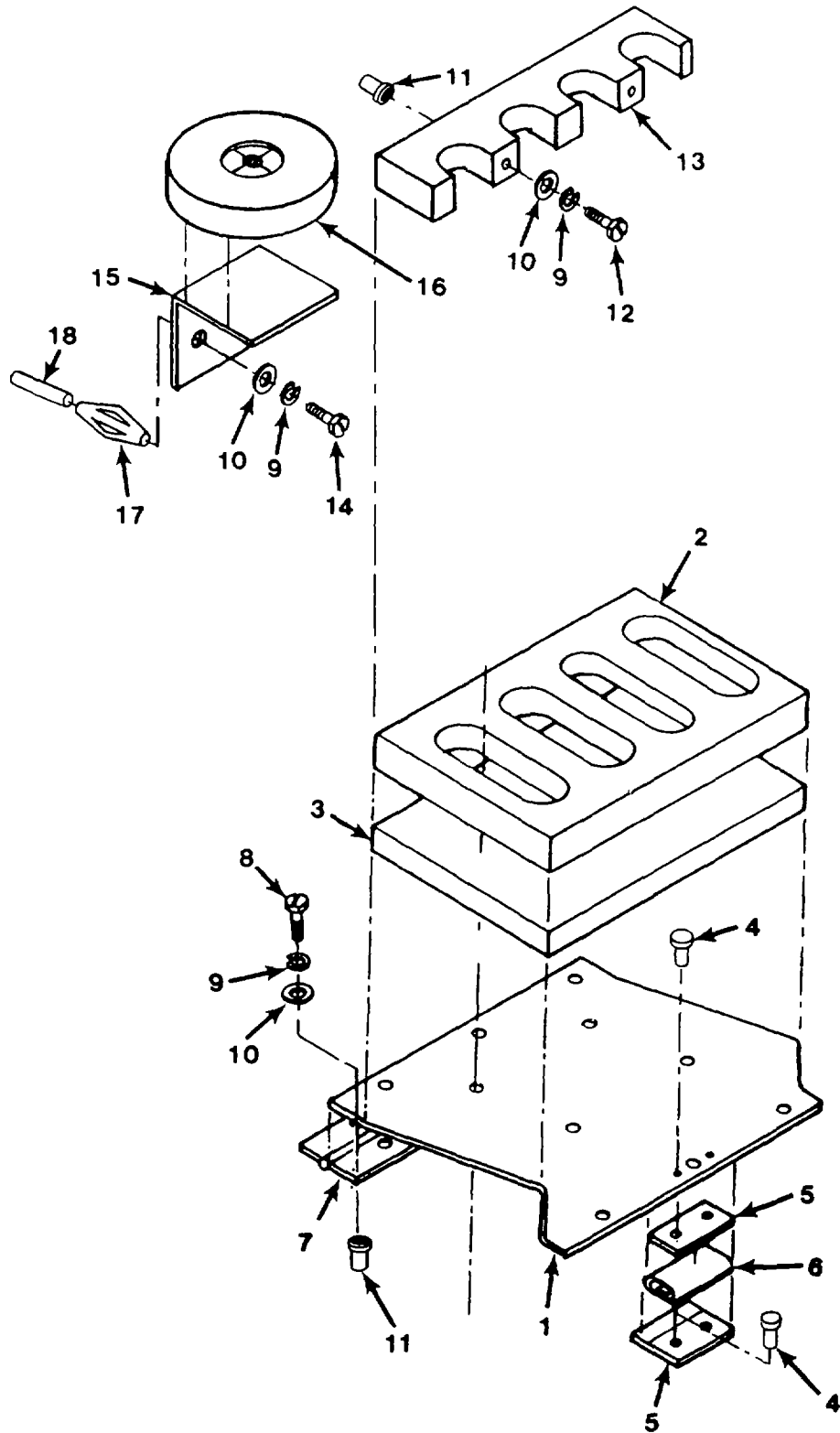

Figure 38. Weapons Rack Installation

SECTION II

TM 5-3610-293-13&P

(1) ITEM NO	(2) SMR CODE	(3) CAGEC	(4) PART NUMBER	(5) DESCRIPTION AND USABLE ON CODES(UOC)	(6) QTY
GROUP 17 RIFLE RACK ASSEMBLY					
FIG. 38 WEAPONS RACK INSTALLATION					
1	XDOOO	81337	5-13-4775	RACK, STORAGE, SMALL	1
2	XDOZZ	97403	13226E4527	.BASE, WEAPONS RACK	1
3	XDOZZ	12621	V778	.SHT, RUBBER	2
4	XDOZZ	96906	MS20600-MP4W6	.RIVET, BLIND .125, .12-.37GRIP	2
5	XDOZZ	81337	5-13-4776	.SPT STRIP	1
6	XDOZZ	81349	MIL-F-21840	.FASTENER, HOOK 1.00 X 2.00, TYPE I,	1
7	XDOZZ	96906	MS35822-9	CLASS 2	1
8	XDOZZ	96906	M535206-264	.HINGE, AL .093, 14.00 X 1.06	1
9	XDOZZ	96906	MS35338-43	.SCREW, MACHINE	7
10	XDOZZ	96906	MS35338-43	.WASHER, LOCK	11
11	XDOZZ	96906	MS15795-442	.WASHER, FLAT	11
12	XDOZZ	96906	MS27130-419	.NUT, RIVET	9
13	XDOZZ	96906	MS35206-270	.SCREW, MACHINE	2
14	XDOZZ	81337	5-13-5027	.RACK, WEAPONS	1
15	XDOZZ	96906	MS35207-267	.SCREW, MACHINE	2
16	XDOZZ	81337	5-13-5016	.BRACKET, LEVEL-ALL	1
17	XDOZZ	84120	05-0065-00	.LEVEL, CIRCULAR	1
18	XDDZZ	81337	5-4-4935	.EXPANDER	2
19	XDDZZ	81337	5-4-4928	.SLEEVE	2

END OF FIGURE

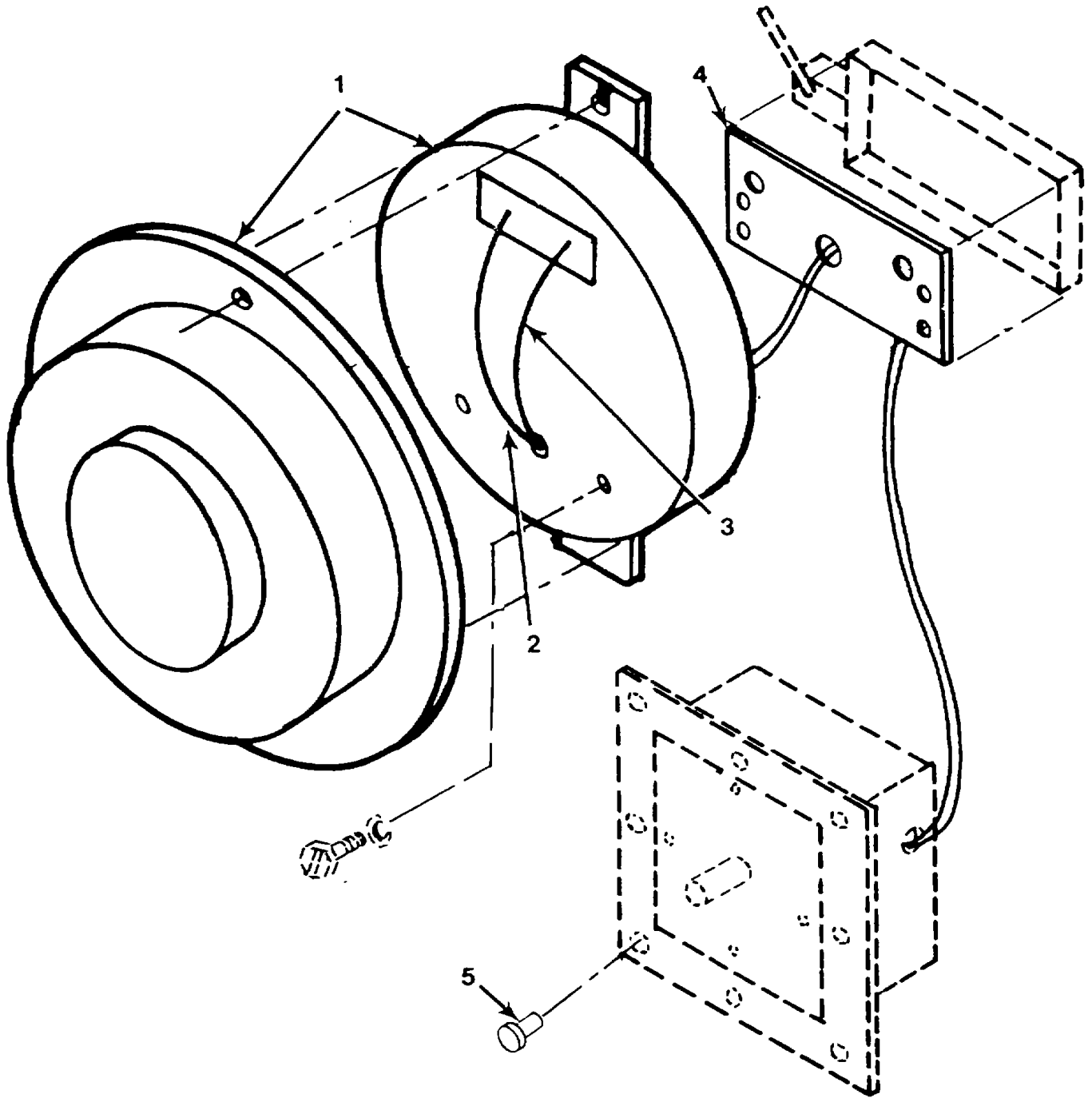

Figure 39. Blackout Buzzer Installation

SECTION II

TM 5-3610-293-13&P

(1) ITEM NO	(2) SMR CODE	(3) CAGEC	(4) PART NUMBER	(5) DESCRIPTION AND USABLE ON CODES(UOC)	(6) QTY
				GROUP 18 BLACKOUT BUZZER ASSEMBLY	
				FIG. 39 BLACKOUT BUZZER INSTALLATION	
	XCOOO	81337	5-13-4789	BLACKOUT BUZ INSTL	1
1	PBOZZ	19557	340-4N5	.BELL, ELECTRICAL.....	1
2	XDOZZ	81349	M16878/5BGE0	.WIRE, ELEC, BLACK 20 AWG	V
3	XDOZZ	81349	M16878/5BGE0	.WIRE, ELEC, WHITE 20 AWG	V
4	XDOZZ	81337	6-1-5888-2	.PLATE, BLACKOUT.....	1
5	XDOZZ	81349	M24243/6-A403H	.RIVET, BLIND	10
				END OF FIGURE	

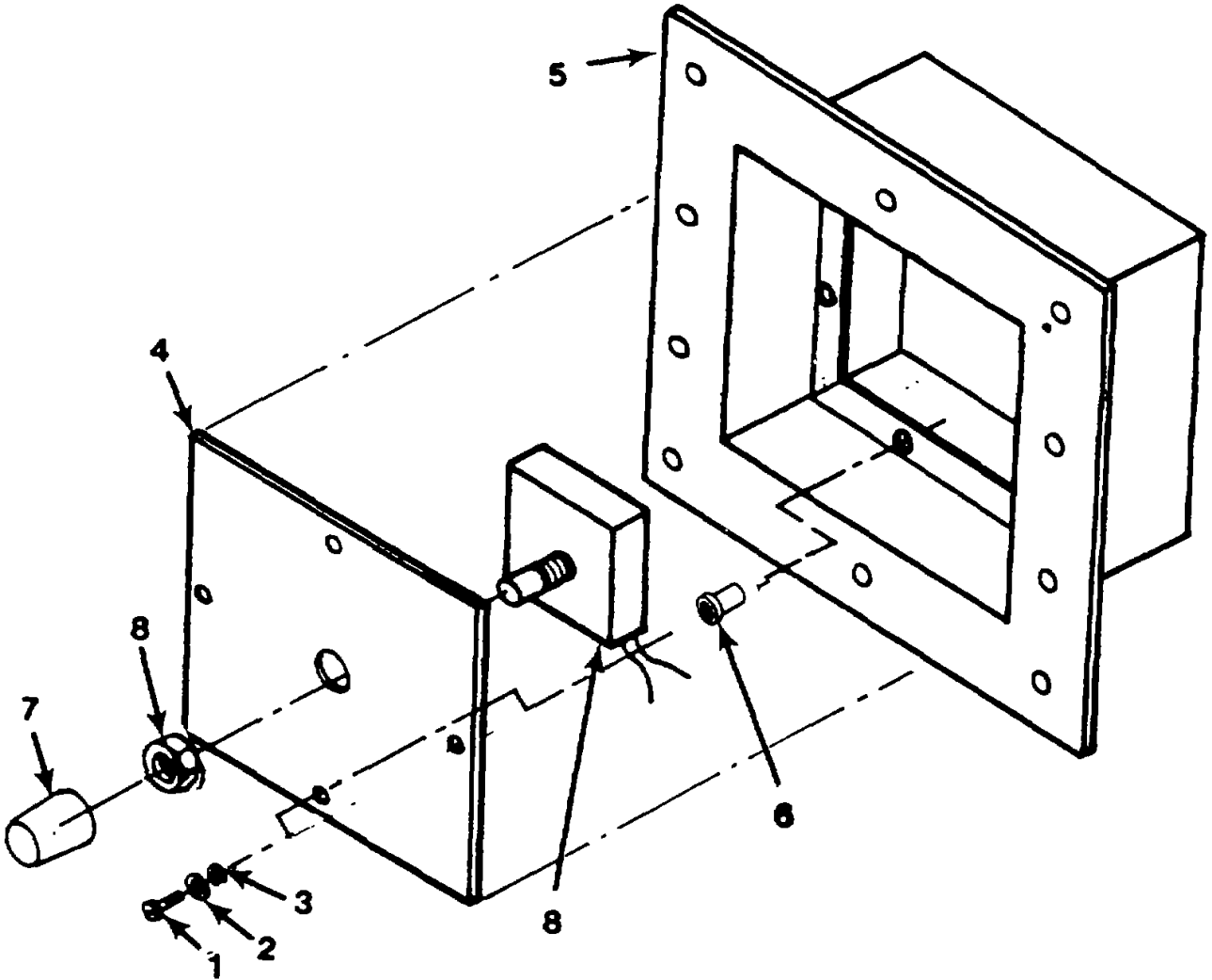

Figure 40. Blackout Switch Assembly

SECTION II

TM 5-3610-293-13&P

(1) ITEM NO	(2) SMR CODE	(3) CAGEC	(4) PART NUMBER	(5) DESCRIPTION AND USABLE ON CODES(UOC)	(6) QTY
GROUP 18 BLACKOUT BUZZED ASSEMBLY					
FIG. 40 BLACKOUT SWITCH ASSEMBLY					
1	XDOZZ	96906	MS35206-245	..SCREW, MACHINE #8-32 X .50	4
2	XDOZZ	96906	MS15795-407	..WASHER, FLAT #8.....	4
3	XDOZZ	96906	MS35338-42	..WASHER, LOCK.....	4
4	XDOZZ	81337	5-13-4990	..CVR, HSNG BLACKOUTSW.....	1
5	XDOZZ	81337	5-13-4989	..HSNG, BLACKOUT SW	1
6	XDOZZ	96906	MS27130-A13	...NUT, PLAIN, BLIND RIV	4
7	PAOZZ	5F993	23F5658	..BOOT, DUST AND MOIST	1
8	PAOZZ	22003	343-0001	..SWITCH, PUSH	1
END OF FIGURE					

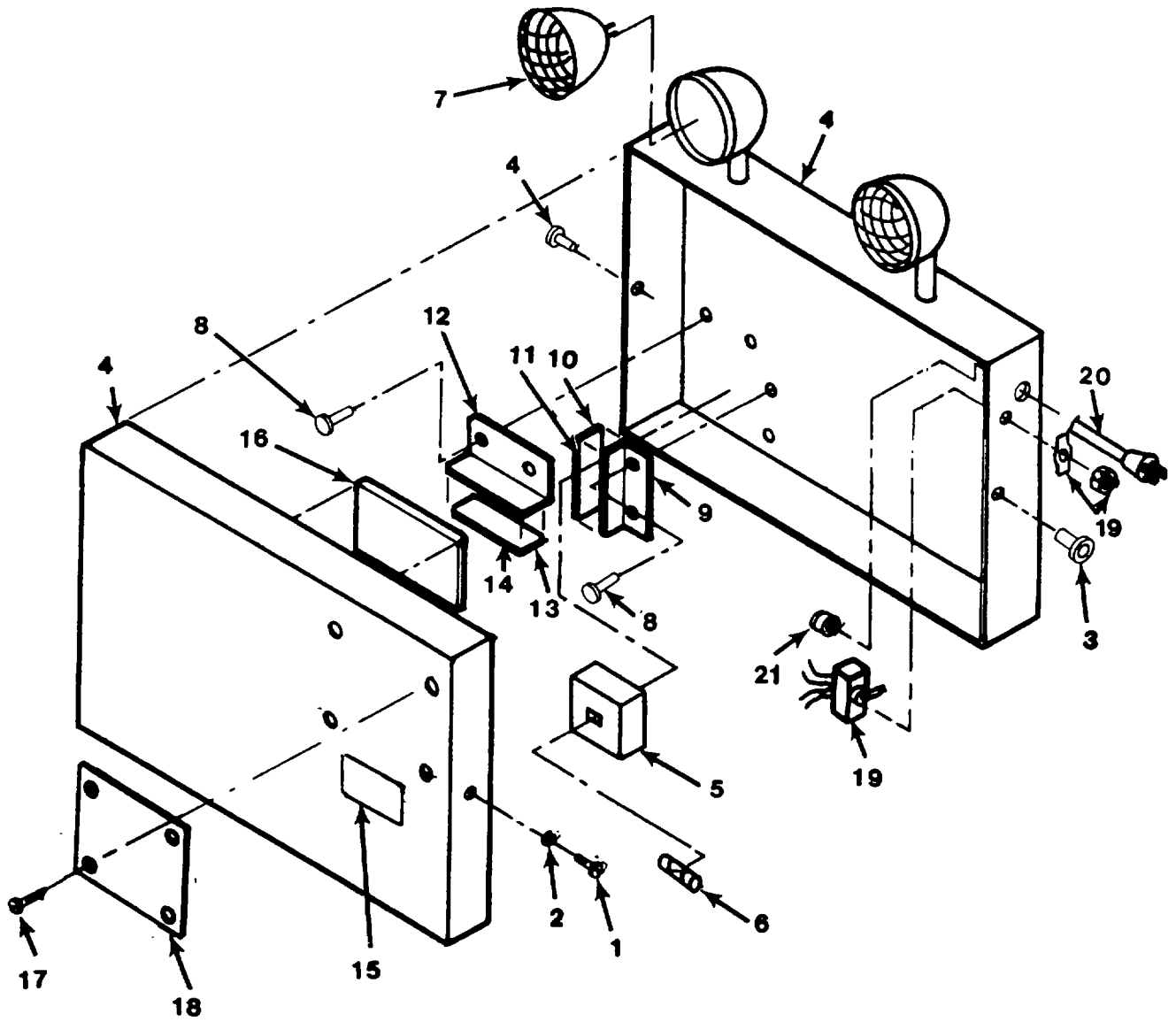

Figure 41. Emergency Light Installation

SECTION II

TM 5-3610-293-13&P

(1) ITEM NO	(2) SMR CODE	(3) CAGEC	(4) PART NUMBER	(5) DESCRIPTION AND USABLE ON CODES(UOC)	(6) QTY
				GROUP 19 MISCELLANEOUS SUPPORT ITEMS	
				FIG. 41 EMERGENCY LIGHT INSTALLATION	
	PBOOO	81337	5-13-4780	..LIGHT UNIT, EMERGENC (SEE FIGURE 11 FOR NHA)	REF
1	XDOZZ	96906	MS35206-263	..SCREW, MACHINE.....	2
2	XDOZZ	96906	M535338-43	..WASHER, LOCK.....	2
3	XDOZZ	96906	MS27130-A19	..NUT, BLIND RIVET 10.24, .01- .12GRIP	2
4	XAOOO	81337	5-13-4781	..EMERG LT, MODULE	1
5	PAOZZ	31795	15330206	..BATTERY, NONRECHARGE SEALED	1
6	PAOZZ	18338	100653-020	..FUSE, CARTRIDGE LOCATED ON	1
7	PAOZZ	08108	4510	PRINTED CIRCUIT BOARD	
				..LAMP, INCANDESCENT 6 VOLT,.....	1
8	XDOZZ	96906	MS20604-B4T6	SEALED BEAM	
9	XDOZZ	81337	5-13-4782-1	..RIVET, BLIND	4
10	XDOZZ	81337	5-13-4782-1-4	..BRACKET, BATTERY	1
11	XDOZZ	81337	5-13-4782-1-1	..SHT, RUBBER	1
12	XDOZZ	81337	5-13-4782-2	..SHT, CRES	1
13	XDDZZ	81337	5-13-4782-2-4	..BRACKET, BATTERY	1
14	XDDZZ	81337	5-13-4782-2-1	..SHT, RUBBER	1
15	XDOZZ	81337	5-13-4783	..SHT, CRES	1
16	XDOZZ	81337	5-13-4780-15	..DECAL	1
17	XDOZZ	96906	MS21318-29	..SHT, RUBBER	1
18	XDOZZ	97403	13227E5726-1	..SCREW, DRIVE	4
19	PAOZZ	96906	MS27735-22	..DATA PLATE	1
20	XDOZZ	07295	100707	..SWITCH, TOGGLE	1
21	XDOZZ	28520	285203210	..CORD, ELEC	1
				..FITTING, LIQ TIGHT	1
				END OF FIGURE	

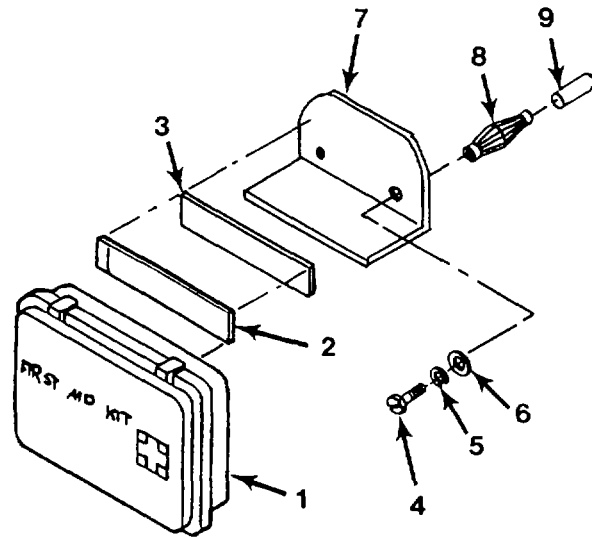

Figure 42. First Aid Kit Assembly

Change 1 F-96

SECTION II

TM 5-3610-293-13&P

(1) ITEM NO	(2) SMR CODE	(3) CAGEC	(4) PART NUMBER	(5) DESCRIPTION AND USABLE ON CODES(UOC) GROUP 19 MISCELLANEOUS SUPPORT ITEMS	(6) QTY
				FIG. 42 FIRST AID KIT ASSEMBLY	
	XDOOO	81337	5-13-4950	ASSY, FIRST AID	1
1	PAOZZ	19207	11677011	.FIRST AID KIT, GENER	1
2	XDOZZ	81349	MIL-F-21840	.FASTENER, HOOK	1
3	XDOZZ	81349	MIL-F-21840	.FASTENER, PILE	1
4	XDOZZ	96906	M535191-274	.SCREW, MACHINE	2
5	XDOZZ	96906	MS35338-43	.WASHER, LOCK	2
6	XDOZZ	96906	MS15795-442	.WASHER, FLAT	2
7	XDOZZ	81337	5-13-4777	.BRACKET, MOUNT	1
8	XDDZZ	81337	5-4-4935	.EXPANDER.....	2
9	XDDZZ	81337	5-4-4928	.SLEEVE	2

END OF FIGURE

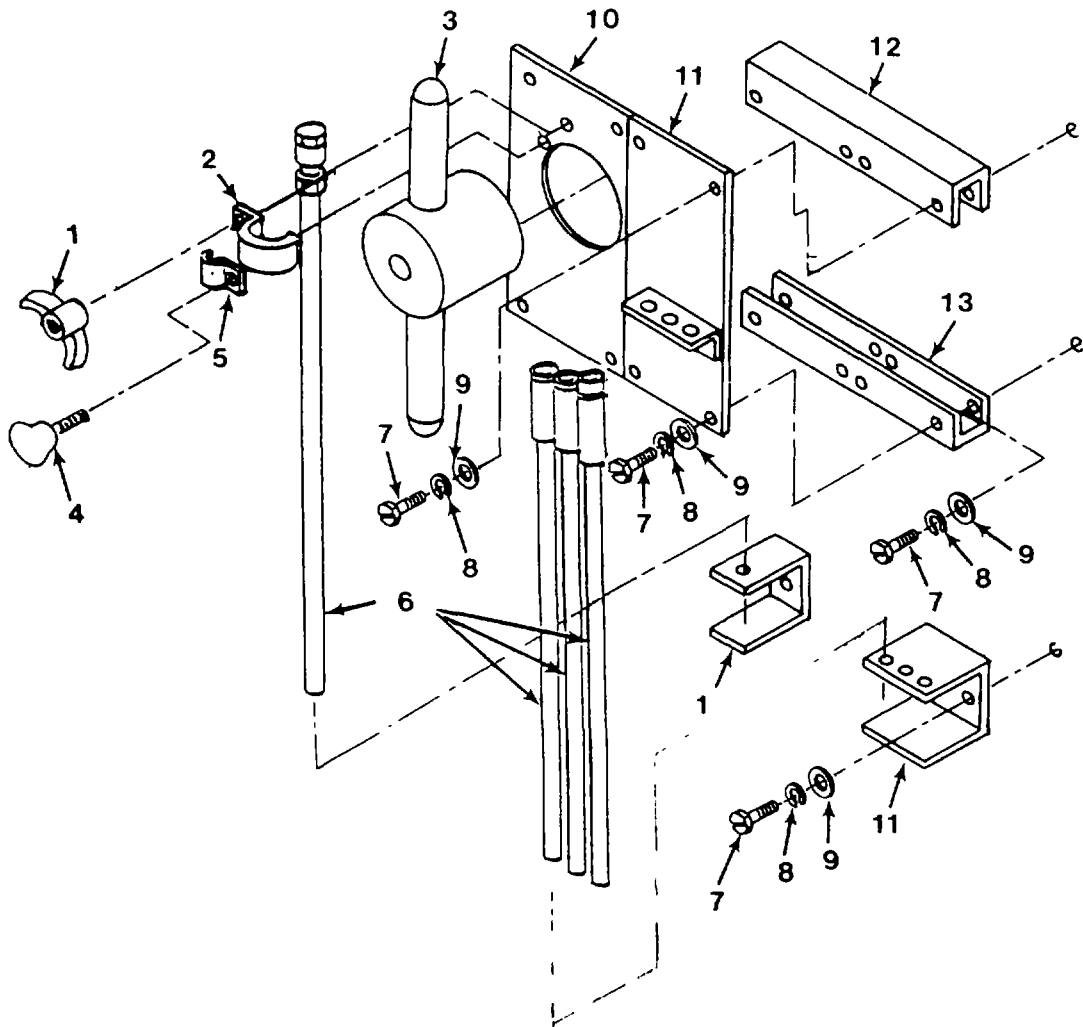

Figure 43. Slide Hammer and Grounding Rod Installation

SECTION II

TM 5-3610-293-13&P

(1) ITEM NO	(2) SMR CODE	(3) CAGEC	(4) PART NUMBER	(5) DESCRIPTION AND USABLE ON CODES(UOC)	(6) QTY
GROUP 19 MISCELLANEOUS SUPPORT ITEMS					
FIG. 43 SLIDE HAMMER AND GROUNDING ROD INSTALLATION					
	XDOOO	81337	5-13-4977	SLIDEHAMMER & GND ROD	1
1	XDOZZ	96906	MS35425-70	.NUT, PLAIN, WING	1
2	XDOZZ	97403	13227E5735	.CLIP, SLIDE HAMMER	1
3	XDOZZ	45225	P74-144	.SLIDE HAMMER, GROUND	1
4	XDOZZ	96906	MS21316-23	.THUMBSCREW	1
5	XDOZZ	96906	MS35140-6	.STRAP, RET	1
6	PAOZZ	82370	A104	.ROD, GROUND	1
7	XDOZZ	96906	MS90728-8	.SCREW, CAP, HEXAGON H	8
8	XDOZZ	96906	MS35338-44	.WASHER, LOCK	8
9	XDOZZ	96906	MS15795-410	.WASHER, FLAT	8
10	XDOZZ	97403	13226E7922	.BRACKET ASSY, SL HAM	1
11	XDOZZ	97403	13225E3143	.BRKT ASSY, GND ROD	1
12	XDOZZ	97403	13227E5689-1	.BRACKET, MTG	1
13	XDOZZ	97403	13227E5689-2	.BRACKET, MTG	1
END OF FIGURE					

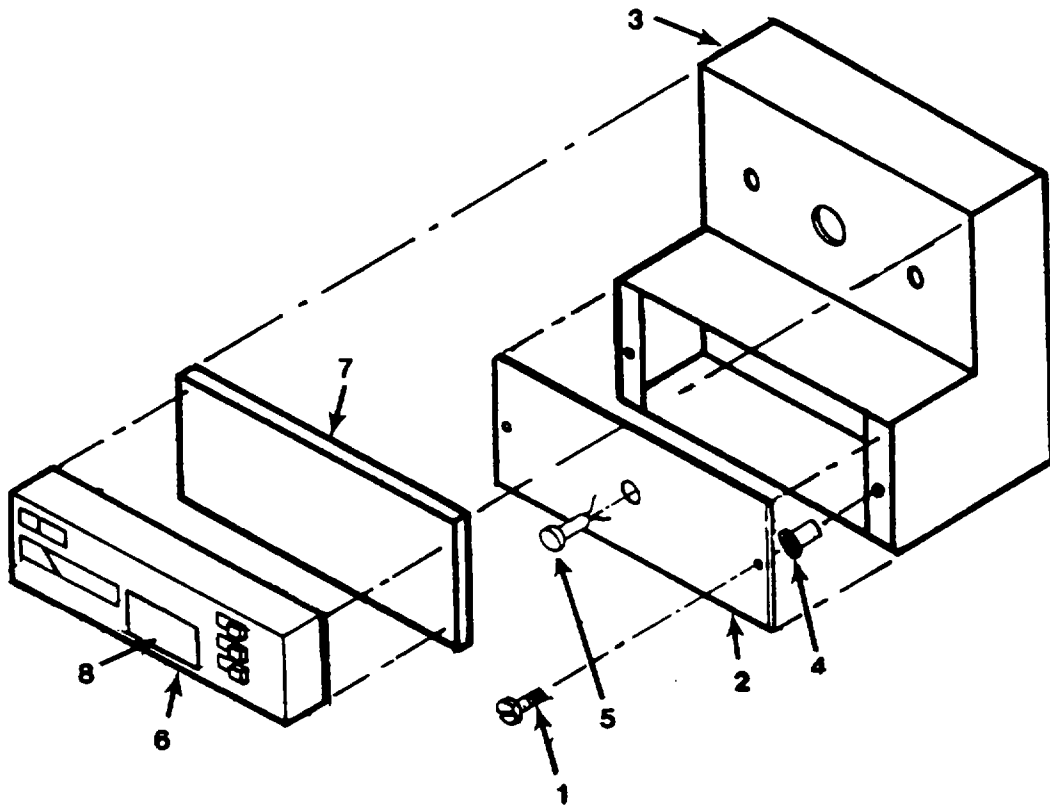

Figure 44. Thermostat Assembly

SECTION II TM 5-3610-293-13&P

(1) ITEM NO	(2) SMR CODE	(3) CAGEC	(4) PART NUMBER	(5) DESCRIPTION AND USABLE ON CODES(UOC)	(6) QTY
GROUP 19 MISCELLANEOUS SUPPORT ITEMS					
FIG. 44 THERMOSTAT ASSEMBLY					
	XDOOO	81337	5-13-4972	.THERMOSTAT ASSY (SEE FIGURE 11 NHA)	REF
1	XDOZZ	96906	MS35206-243	..SCREW, MACHINE	2
2	XDOZZ	81337	5-13-4974	..LID, THERMOSTAT BOX	1
3	XDOZZ	81337	5-13-4973	..BOX, THERMOSTAT	1
4	XDOZZ	96906	MS27130-A13	..NUT, PLAIN, BLIND RIV	2
5	PAOZZ	72619	508-8738-504	..LIGHT, INDICATOR	1
6	XDOZZ	4R884	HP11-51	..THERMOSTAT	1
7	XDOZZ	52359	Q674L1181	..SUB-BASE, THERMOSTAT	1
8	XDOZZ	81337	5-13-4976	..DECAL	1

END OF FIGURE

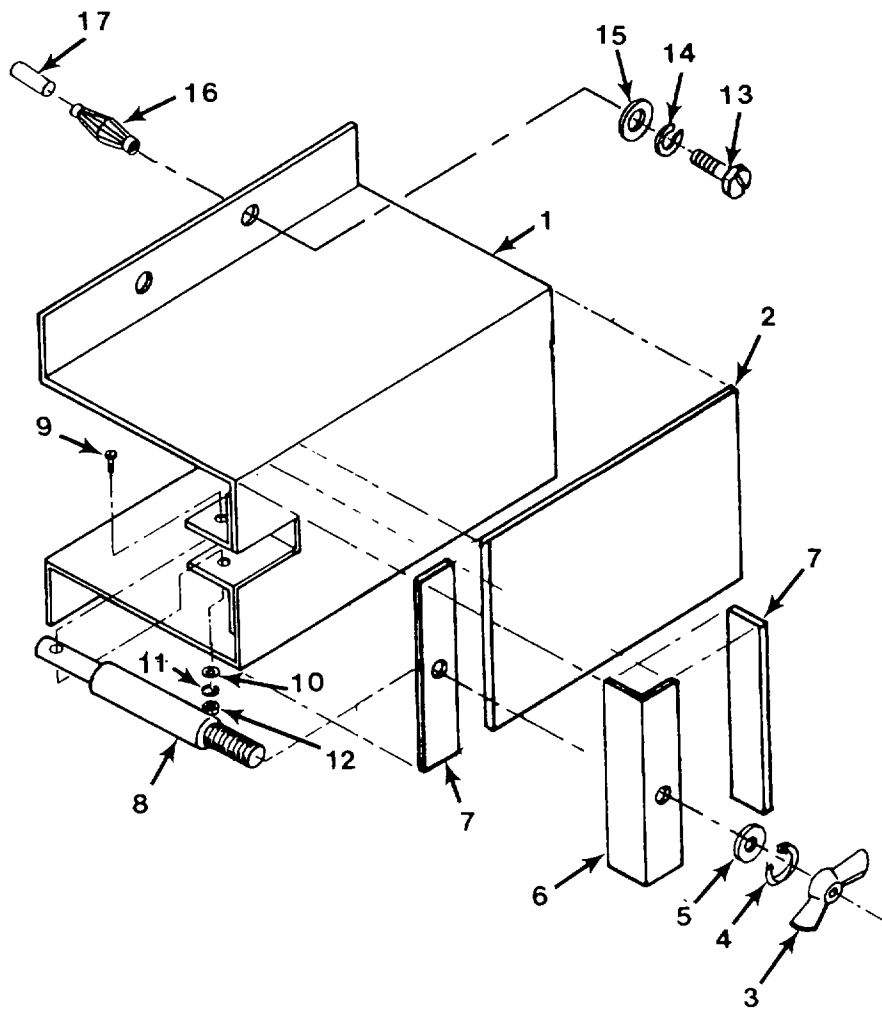

Figure 45. Storage Clamp Assembly

SECTION II

TM 5-3610-293-13&P

(1) ITEM NO	(2) SMR CODE	(3) CAGEC	(4) PART NUMBER	(5) DESCRIPTION AND USABLE ON CODES(UOC)	(6) QTY
GROUP 19 MISCELLANEOUS SUPPORT ITEMS					
FIG. 45 STORAGE CLAMP ASSEMBLY					
	XDOOO	81337	5-13-4830	ASSY, STORAGE CLAMP	1
1	XDDZZ	81337	5-13-4728	.SUPPORT, WELD ASSY	1
2	XDOZZ	81349	M6855/1-023211	.SHEET, RUBBER	1
3	XDOZZ	96906	MS35425-74	.NUT, PLAIN, WING	1
4	XDOZZ	96906	MS35338-46	.WASHER, LOCK	1
5	XDOZZ	96906	MS15795-413	.WASHER, FLAT	1
6	XDOZZ	81337	5-13-4730	.CLAMP	1
7	XDOZZ	81349	M6855/1-041211	.SHEET, RUBBER	1
8	XDOZZ	81337	5-13-4729	.STUD, LOCKING	1
9	XDOZZ	96906	MS35206-265	.SCREW, MACHINE	1
10	XDOZZ	96906	MS15795-442	.WASHER, FLAT	1
11	XDOZZ	96906	MS35338-43	.WASHER, LOCK	1
12	XDOZZ	96906	MS35649-202	.NUT, PLAIN, HEXAGON	1
13	XDOZZ	96906	MS90726-8	.SCREW, HEXAGON HD	8
14	XDOZZ	96906	MS35338-44	.WASHER, LOCK	8
15	XDOZZ	96906	MS15795-410	.WASHER, FLAT	8
16	XDDZZ	81337	5-4-4934	.EXPANDER	8
17	XDDZZ	81337	5-4-4831	.SLEEVE	8

END OF FIGURE

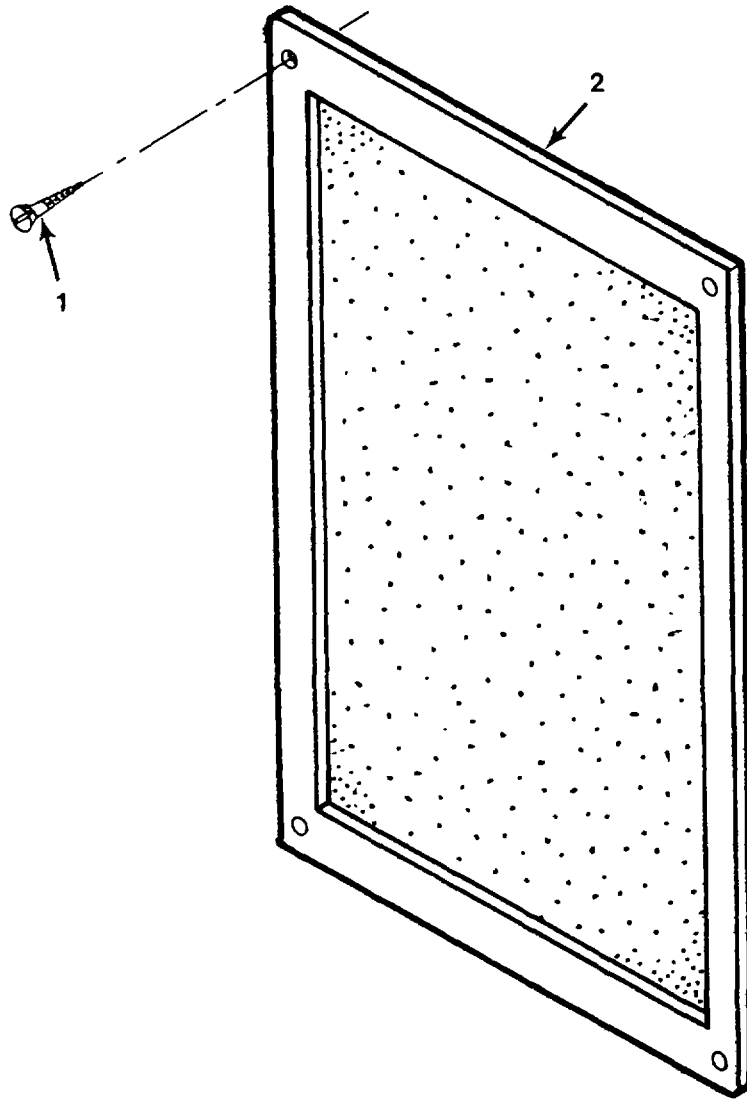

Figure 46. Bulletin Board

SECTION II

TM 5-3610-293-13&P

(1) ITEM NO	(2) SMR CODE	(3) CAGEC	(4) PART NUMBER	(5) DESCRIPTION AND USABLE ON CODES(UOC)	(6) QTY
-------------------	--------------------	--------------	-----------------------	---	------------

GROUP 19 MISCELLANEOUS SUPPORT ITEMS

FIG. 46 BULLETIN BOARD

1	XDOZZ	96906	M535201-263	.SCREW,MACHINE	4
2	XDOZZ	81337	5-13-4988	BULLETIN BOARD	1

END OF FIGURE

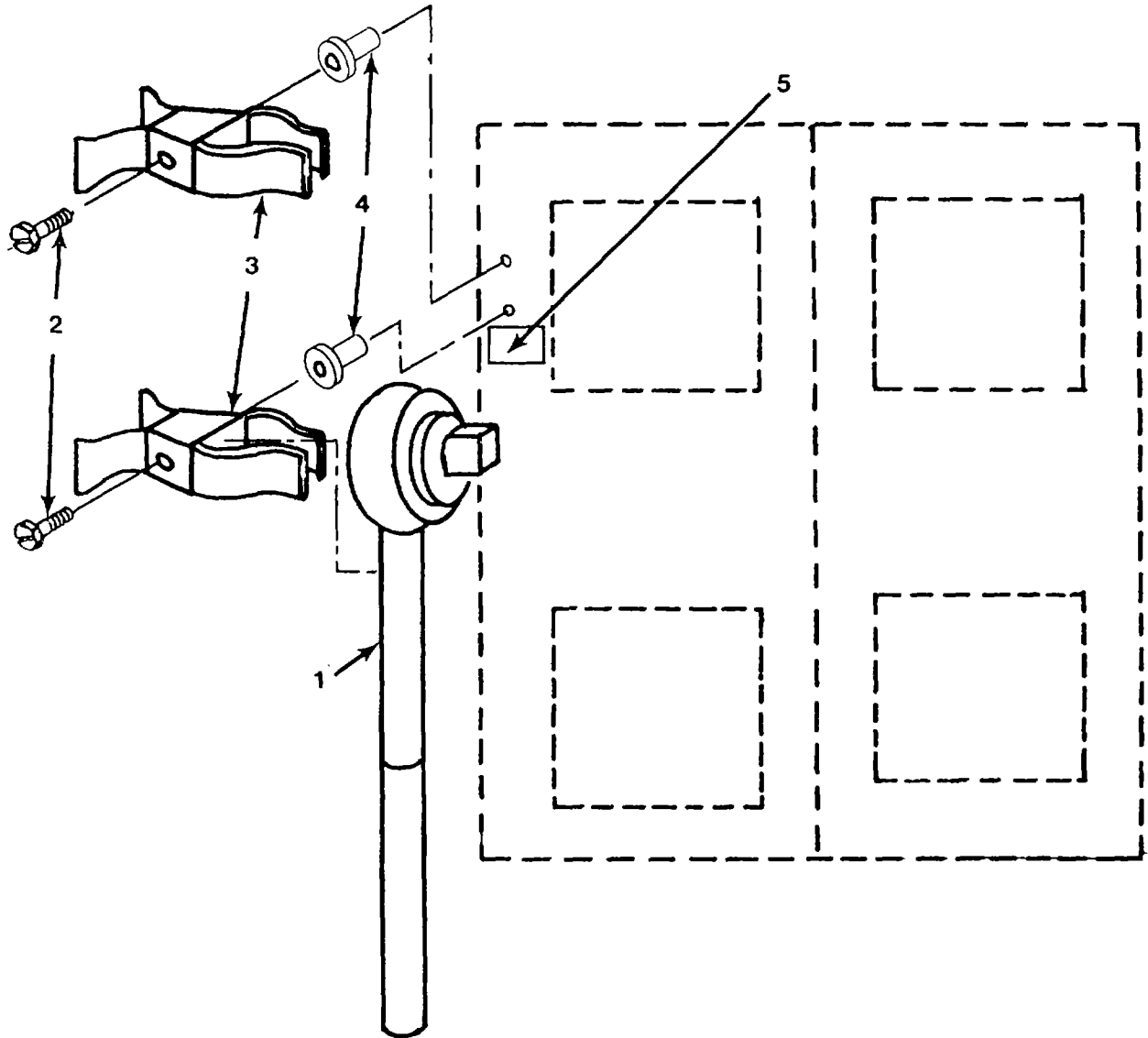

Figure 47. Solar Bar Wrench Handle Installation

SECTION II

TM 5-3610-293-13&P

(1) ITEM NO	(2) SMR CODE	(3) CAGEC	(4) PART NUMBER	(5) DESCRIPTION AND USABLE ON CODES(UOC)	(6) QTY
GROUP 19 MISCELLANEOUS SUPPORT ITEMS					
FIG. 47 SOLAR BAR WRENCH HANDLE INSTALLATION					
	XDOZZ	81337	5-13-5000	HANDLE, WRENCH, SB	1
1	XDOZZ	81348	GGG-W-641	.HANDLE, SOCKET WR PAINT RED	1
2	XDOZZ	96906	MS35206-245	.SCREW, MACHINE 8-32 X .50	2
3	XDOZZ	81337	5-4-5106	.CLIP, SPRING TENSION	2
4	XDOZZ	96906	MS27130-A13	.NUT, PLAIN, BLIND RIV	2
5	XDOZZ	81337	5-13-4720	.STENCIL, .25, BLACK SOCKET HANDLE,	1
				STORAGE LOCATION.....	

END OF FIGURE

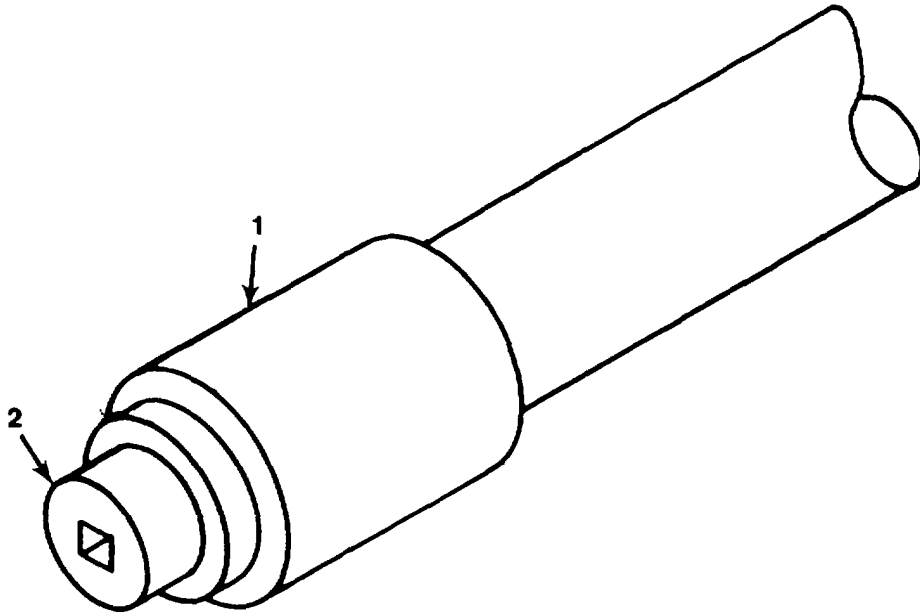

Figure 48. Solar Bar Handle Modifications

SECTION II

TM 5-3610-293-13&P

(1) ITEM NO	(2) SMR CODE	(3) CAGEC	(4) PART NUMBER	(5) DESCRIPTION AND USABLE ON CODES(UOC)	(6) QTY
GROUP 19 MISCELLANEOUS SUPPORT ITEMS					
FIG. 48 SOLAR BAR HANDLE MODIFICATIONS					
	XDOZZ	81337	5-13-5033	HANDLE, SOLAR BAR MO	1
1	XDDZZ	81337	5-4-3050	.SOLAR BAR, MODIFIED SEE TM 10-5411-..... 200-24P FOR PART NUMBER OF UNMODIFIED SOLAR BAR MODIFY BY CUTTING OFF HANDLE AND WELDING ON SOCKET P240	1
2	XDDZZ	55719	P240	.SOCKET, WRENCH NOTE: CUT OFF 1/2..... IN THICK AND WELD TO SOLAR BAR	1

END OF FIGURE

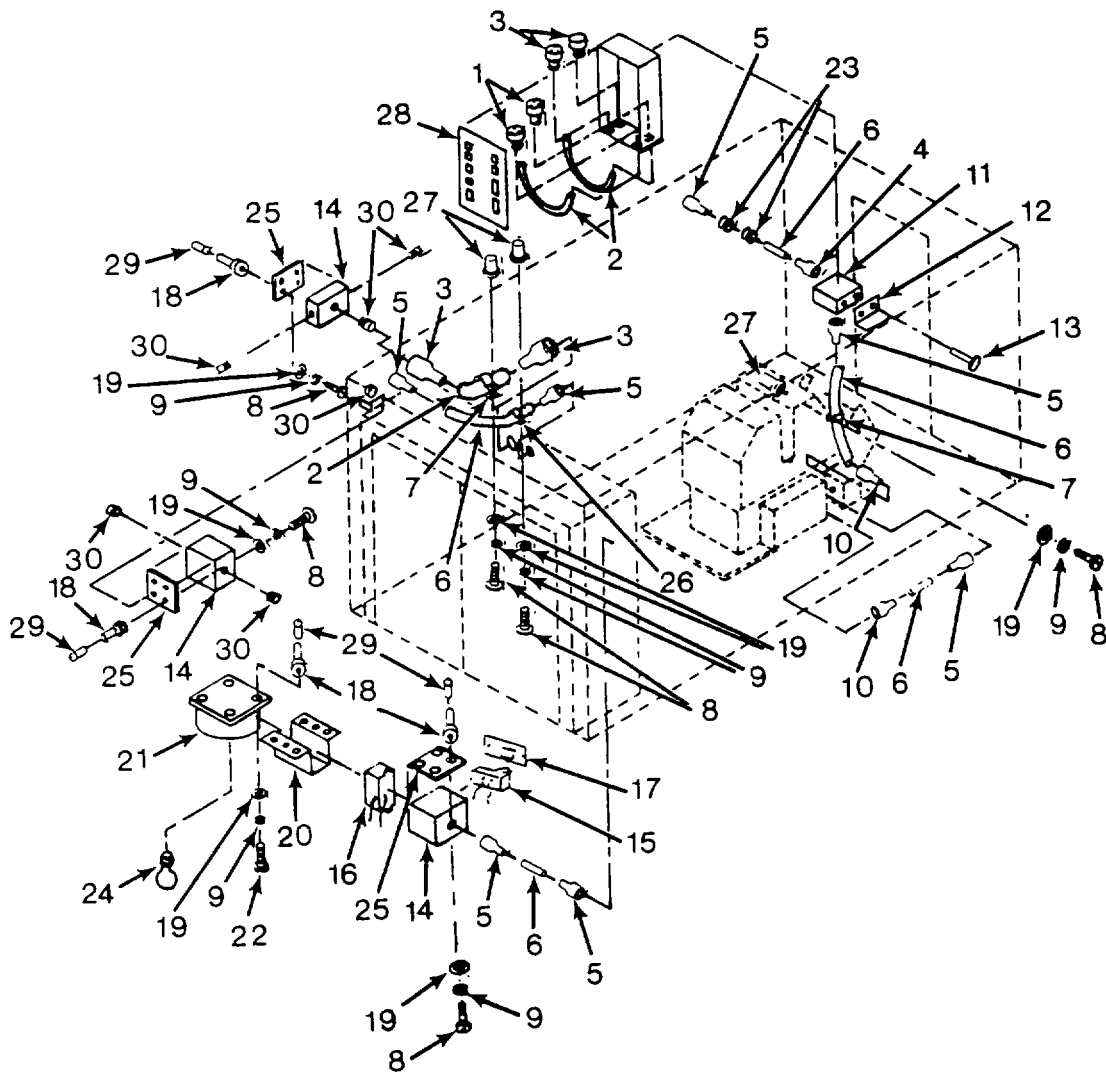

Figure 49. Electrical Installation

SECTION II

TM 5-3610-293-13&P

(1) ITEM NO	(2) SMR CODE	(3) CAGEC	(4) PART NUMBER	(5) DESCRIPTION AND USABLE ON CODES(UOC)	(6) QTY
GROUP 19 MISCELLANEOUS SUPPORT ITEMS					
FIG. 49 ELECTRICAL INSTALLATION					
	XCOOO	81337	5-13-4907	ELEC INSTAL	1
1	XDOZZ	96906	5975-00-995-2168	.CONN, CONDUIT	2
2	XDOZZ	97403	13227E5736	.CONDUIT, LQ TIGHT	V
3	XDOZZ	97403	13227E6253	.CONN, CONDUIT	4
4	XDOZZ	97403	13227E	.CONN, CONDUIT	1
5	XDOZZ	39428	7119K12	.CONN, CONDUIT	7
6	XDOZZ	39428	7127K25	.CONDUIT, LQ TIGHT	V
7	XDOZZ	96906	MS35140-14	.STRAP, RETAINING	3
8	XDOZZ	96906	MS35191-272	.SCREW, MACHINE	18
9	XDOZZ	96906	MS35338-43	.WASHER, LOCK	22
10	XDOZZ	39428	7119K21	.CONN, CONDUIT	2
11	XDOOO	81337	5-13-5013	.BOX, ELEC MODS	1
12	XDOZZ	29215	JP2050-1	..JUNCTION BOX	1
13	XDOZZ	97403	13226E6991	..BRACKET, TOOL BX	2
14	XDOZZ	81349	MIL-R-24243/6-A4 04H	..RIVET	4
15	XDOZZ	79725	2151-2	.BOX, RECP	2
16	PAOZZ	74545	1221PL	.SWITCH, TOGGLE	1
17	XDOZZ	81349	WC596/12-4	.OUTLET, RECP	1
18	XDOZZ	23828	1138V	.CVR, SW & RECP	1
19	XDOZZ	81337	5-4-4984	.EXPANDER	12
20	XDOZZ	96906	M515795-408	.WASHER, FLAT	25
21	XDOZZ	03350	200	.RACEWAY SURFACE	V
22	XDOZZ	16327	2V637	.LIGHT ASSY	1
23	XDOZZ	96906	MS35191-277	.SCREW, MACHINE	4
24	XDOZZ	76385	Z-4023	.GROMMET	2
25	PAOZZ	88204	52A/SS	.LAMP, INCANDESCENT 52 WATT	1
26	XDOZZ	90759	400	.CVR, BX	2
27	XDOZZ	96906	MS35140-12	.STRAP, RETAINING	3
28	XDOZZ	96906	MS27130-A29	.NUT, BLIND RIVET	13
29	XCOOO	81337	5-13-4980	.PANEL, BD, MOD	1
30	XDOZZ	81337	5-4-4928	.SLEEVE	12
31	XDOZZ	28520	3210	.FITTING, LQ TIGHT	4

END OF FIGURE

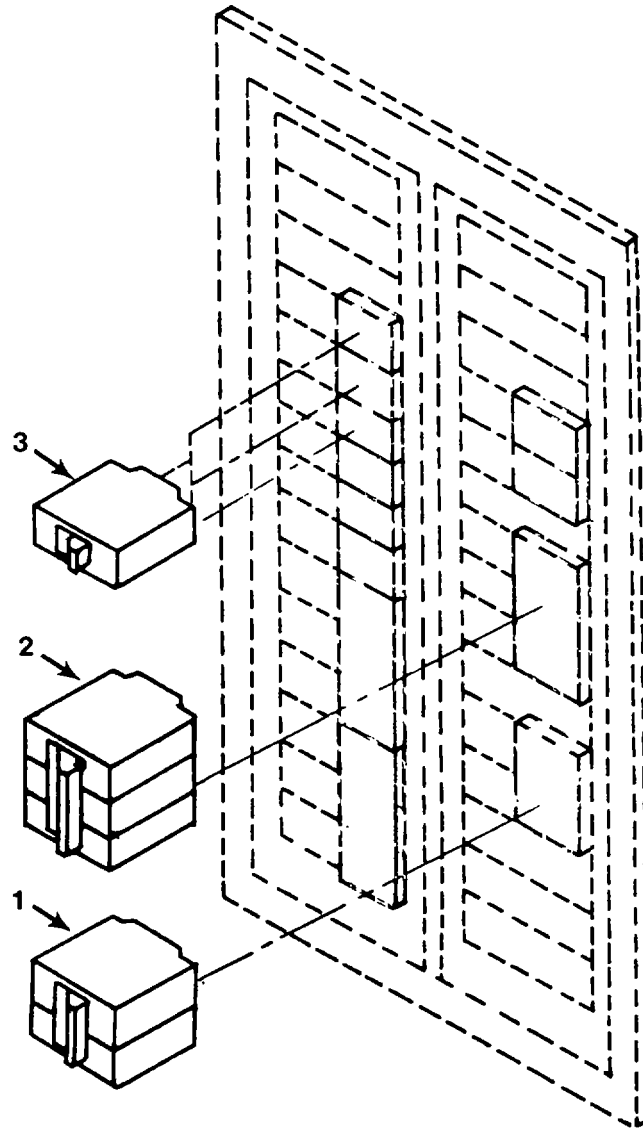

Figure 50. Power Panel Modifications

SECTION II

TM 5-3610-293-13&P

(1) ITEM NO	(2) SMR CODE	(3) CAGEC	(4) PART NUMBER	(5) DESCRIPTION AND USABLE ON CODES(UOC)	(6) QTY
-------------------	--------------------	--------------	-----------------------	---	------------

GROUP 19 MISCELLANEOUS SUPPORT ITEMS

FIG. 50 POWER PANEL MODIFICATIONS

1	PBOZZ	56365	QOB250	..CIRCUIT BREAKER OLE, 50 AMP	1
2	PBOZZ	56365	QOB340	..CIRCUIT BREAKER OLE, 40 AMP	1
3	PBOZZ	56365	QOB120	..CIRCUIT BREAKER OLE, 20 AMP	3

END OF FIGURE

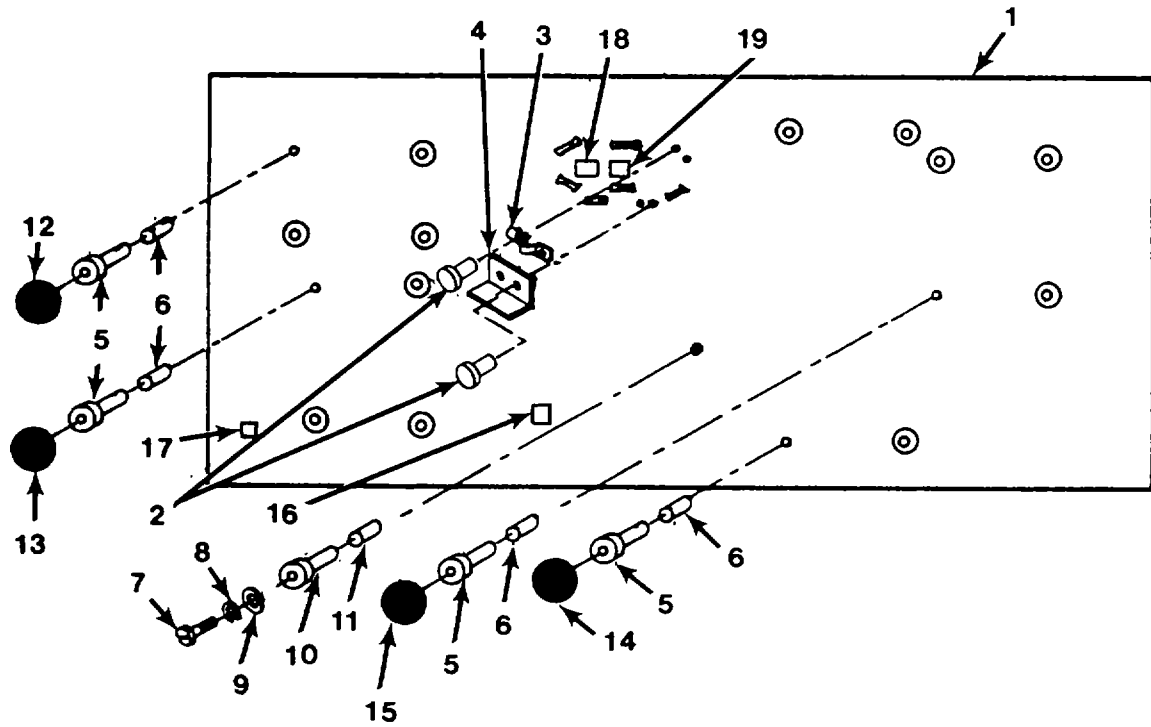

Figure 51. Floor Inserts Installation

SECTION II

TM 5-3610-293-13&P

(1) ITEM NO	(2) SMR CODE	(3) CAGEC	(4) PART NUMBER	(5) DESCRIPTION AND USABLE ON CODES(UOC)	(6) QTY
GROUP 19 MISCELLANEOUS SUPPORT ITEMS					
FIG. 51 FLOOR INSERTS INSTALLATION					
1	XCDDD	81337	5-13-4702	INSERTS, FL, FINISH	1
2	XDOZZ	81349	MIL-R-24243/3-B4 04	.RIVET	16
3	XDOZZ	96906	MS51939-1	.LOOP, STRAP FASTENER	6
4	XDOZZ	97403	13226E6991	.BRACKET, TOOL BX	2
5	XDDZZ	81337	5-4-4968	.EXPANDER.....	22
6	XDDZZ	81337	5-4-4930	.SLEEVE	22
7	XDOZZ	96906	MS90726-8	.SCREW,HEXAGON HD	18
8	XDOZZ	96906	MS35338-44	.WASHIER, LOCK	60
9	XDOZZ	96906	MS15795-410	.WASHER, FLAT	60
10	XDDZZ	81337	5-4-4934	.EXPANDER	60
11	XDDZZ	81337	5-4-4831	.SLEEVE	60
12	XDOZZ	81337	5-13-4718	.STENCIL, 1.5DOT BRN	4
13	XDOZZ	81337	5-13-4718	.STENCIL, 1.5DOT BLU	4
14	XDOZZ	81337	5-13-4718	.STENCIL, 1.5DOT BLK	4
15	XDOZZ	81337	5-13-4718	.STENCIL, 1.5DOT RED	4
16	XDOZZ	81337	5-13-4822	.STENCIL, .5, BLACK FLOOR MAT STORAGE	1
17	XDOZZ	81337	5-13-4822	.STENCIL, .5, BLACK TRASH CAN STORAGE	1
18	XDOZZ	81337	5-13-4822	.STENCIL, .5, BLACK FLAMMABLE WASTE..... CAN STORAGE	1
19	XDOZZ	81337	5-13-4822	.STENCIL, .5, BLACK FLAMMABLE LIQUID..... CAN STORAGE	1

END OF FIGURE

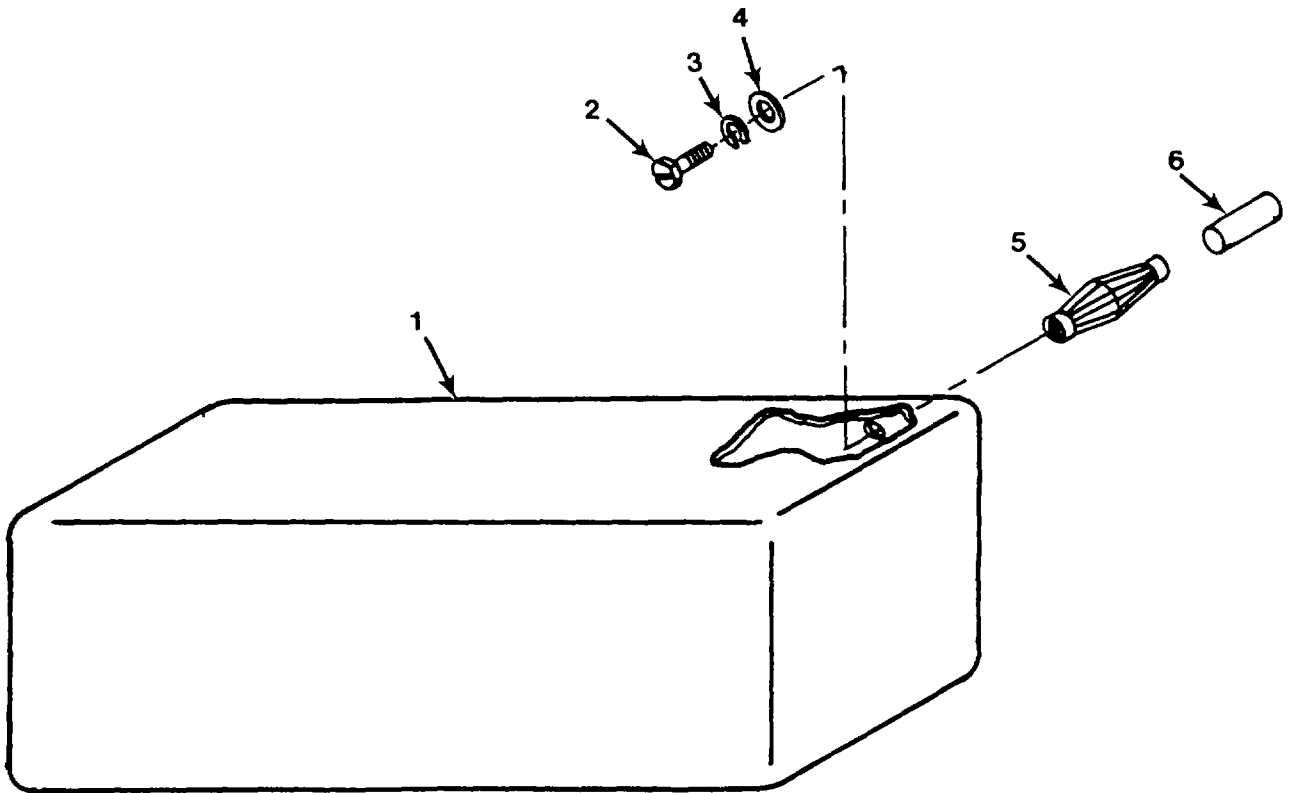

Figure 52. Towel Dispenser Assembly

SECTION II

TM 5-3610-293-13&P

(1) ITEM NO	(2) SMR CODE	(3) CAGEC	(4) PART NUMBER	(5) DESCRIPTION AND USABLE ON CODES(UOC)	(6) QTY
-------------------	--------------------	--------------	-----------------------	---	------------

GROUP 19 MISCELLANEOUS SUPPORT ITEMS

FIG. 52 TOWEL DISPENSER ASSEMBLY

1	XDOZZ	81348	WW-D, 1909, TY1	.DISPENSER, TOWEL	1
2	XDOZZ	96906	MS35191-274	.SCREW, MACHINE	4
3	XDOZZ	96906	MS35338-43	.WASHER, LOCK	4
4	XDOZZ	96906	MS15795-442	.WASHER, FLAT	4
5	XDDZZ	81337	5-4-4935	.EXPANDER.....	4
6	XDDZZ	81337	5-4-4928	.SLEEVE	4

END OF FIGURE

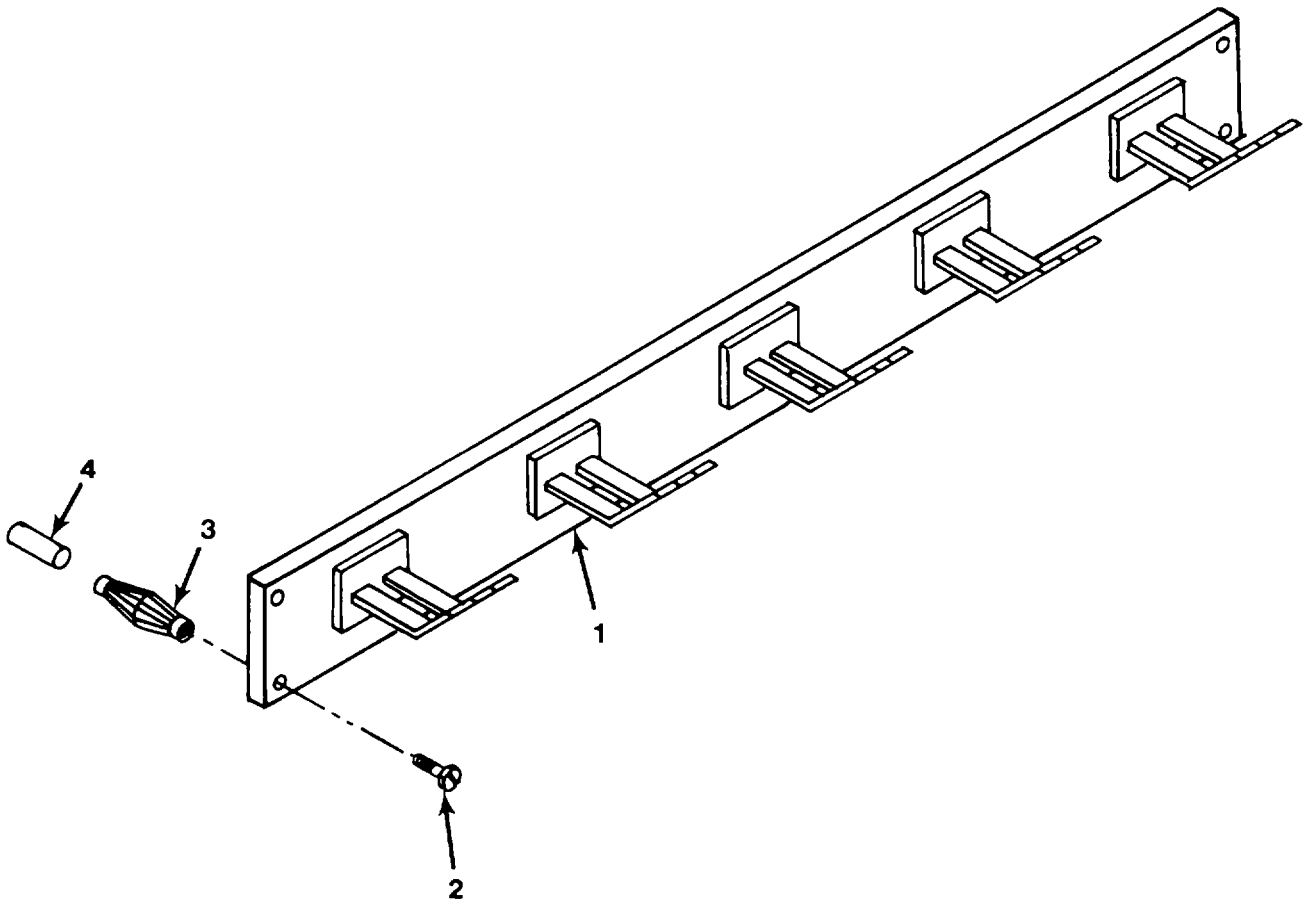

Figure 53. Coat Rack Assembly

SECTION II

TM 5-3610-293-13&P

(1) ITEM NO	(2) SMR CODE	(3) CAGEC	(4) PART NUMBER	(5) DESCRIPTION AND USABLE ON CODES(UOC)	(6) QTY
-------------------	--------------------	--------------	-----------------------	---	------------

GROUP 19 MISCELLANEOUS SUPPORT ITEMS

FIG. 53 COAT RACK ASSEMBLY

1	XDOZZ	97403	13226E4508	.RACK, COAT	1
2	XDOZZ	96906	MS24693-280	.SCREW, MACHINE	4
3	XDDZZ	81337	5-4-4935	.EXPANDER	4
4	XDDZZ	81337	5-4-4928	.SLEEVE	4

END OF FIGURE

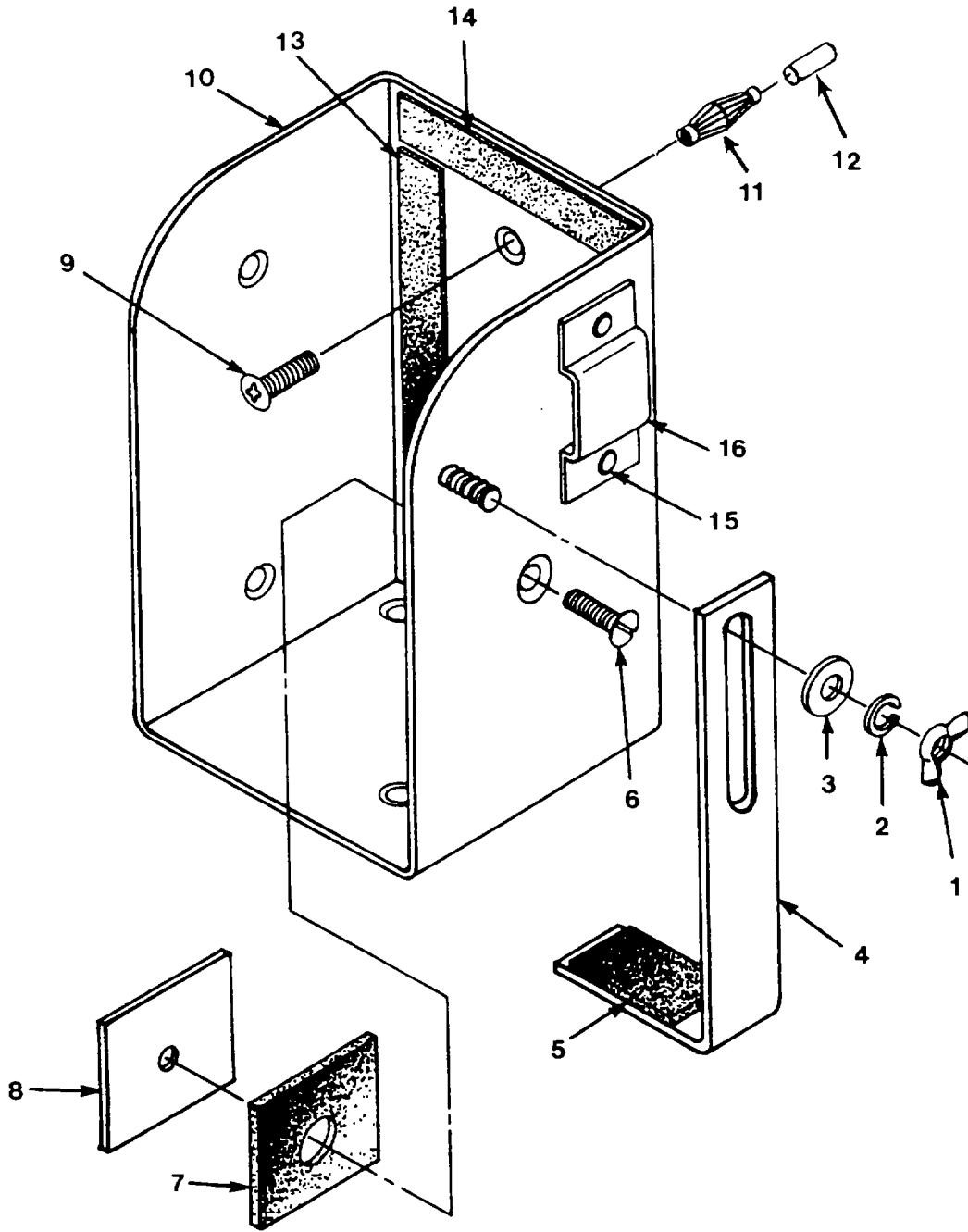

Figure 54. Telephone Bracket Assembly

SECTION II

TM 5-3610-293-13&P

(1) ITEM NO	(2) SMR CODE	(3) CAGEC	(4) PART NUMBER	(5) DESCRIPTION AND USABLE ON CODES(UOC)	(6) QTY
GROUP 19 MISCELLANEOUS SUPPORT ITEMS					
FIG. 54 TELEPHONE BRACKET ASSEMBLY					
	XDOOO	81337	6-1-7543	ASSY, TELEPHONE BRAC	1
1	XDOZZ	96906	M535425-70	.NUT, PLAIN, WING	1
2	XDOZZ	96906	MS35338-44	.WASHER, LOCK	1
3	XDOZZ	96906	MS27183-10	.WASHER, FLAT	1
4	XDOZZ	81337	6-1-7543-2	.SLIDE	1
5	XDOZZ	81337	6-1-7543-8	.PAD, SLIDE	1
6	XDOZZ	96906	MS35190-287	.SCREW, MACHINE	1
7	XDOZZ	81337	6-1-7543-5	.PAD, PLATE	1
8	XDOZZ	81337	6-1-7543-4	.PLATE	1
9	XDOZZ	96906	MS35191-291	.SCREW, MACHINE	2
10	XDOZZ	81337	6-1-7543-1	.BOX, PHONE MOUNTING	1
11	XDDZZ	81337	5-4-4934	.EXPANDER	2
12	XDDZZ	81337	5-4-4831	.SLEEVE	2
13	XDOZZ	81337	6-1-7543-6	.PAD, BOX	1
14	XDOZZ	81337	6-1-7543-7	.PAD, BOX	1
15	XDOZZ	96906	MS20470-AD6-8	.RIVET, SOLID	2
16	XDOZZ	81337	6-1-7543-3	.RETAINER	1

END OF FIGURE

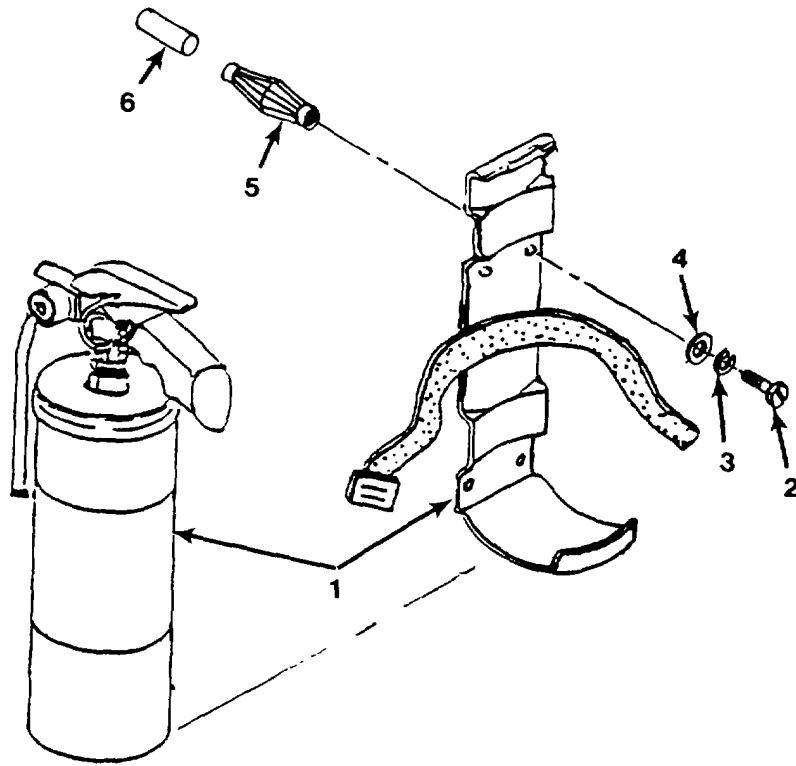

Figure 55. Fire Extinguisher Assembly

SECTION II

TM 5-3610-293-13&P

(1) ITEM NO	(2) SMR CODE	(3) CAGEC	(4) PART NUMBER	(5) DESCRIPTION AND USABLE ON CODES(UOC)	(6) QTY
-------------------	--------------------	--------------	-----------------------	---	------------

GROUP 19 MISCELLANEOUS SUPPORT ITEMS

FIG. 55 FIRE EXTINGUISHER ASSEMBLY

1	PAOZZ	58536	A-A-393	.EXTINGUISHER, FIRE, D	2
2	XDOZZ	96906	MS35207-263	.SCREW, MACHINE	4
3	XDOZZ	96906	MS35338-43	.WASHER, LOCK	4
4	XDOZZ	96906	MS15795-442	.WASHER, FLAT	4
5	XDDZZ	81337	5-4-4935	.EXPANDER.....	4
6	XDDZZ	81337	5-4-4928	.SLEEVE	4

END OF FIGURE

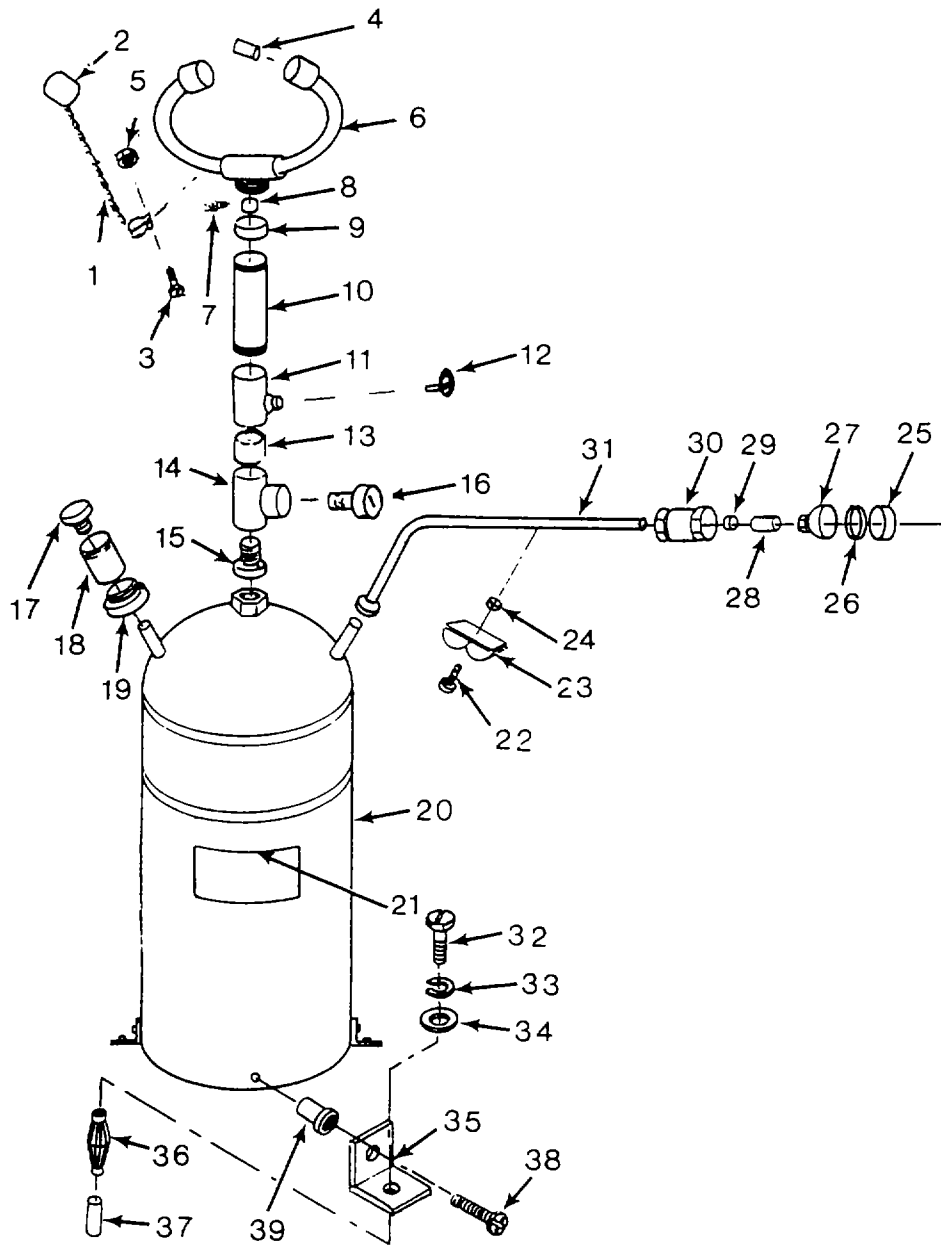

Figure 56. Eye Wash Assembly

SECTION II

TM 5-3610-293-13&P

(1) ITEM NO	(2) SMR CODE	(3) CAGEC	(4) PART NUMBER	(5) DESCRIPTION AND USABLE ON CODES(UOC)	(6) QTY
GROUP 19 MISCELLANEOUS SUPPORT ITEMS					
FIG. 56 EYE WASH ASSEMBLY					
	PBOOZ	87327	SE-590	..EYE-FACE WASH, PORTA	1
1	XDOZZ	87327	G05-0461	..CHAIN, DUST COVER	2
2	XDOZZ	87327	07-0065	..DUST COVER	2
3	XDOZZ	87327	8-0116	..SCREW	2
4	XDOZZ	87327	8-0234	..SPRAY NOZZLE	2
5	XDOZZ	87327	01-0632	..NUT	1
6	XDOZZ	87327	G24-0075	..TEE & TUBE ASSY	1
7	XDOZZ	87327	8-0275	..SCREW, BALANCE	1
8	XDOZZ	87327	20-0830	..FLOW CONTROL, .4GPM	1
9	XDOZZ	87327	05-0478	..SOCKET, 3/8 COVER	1
10	XDOZZ	87327	31-0292	..PIPE, 3/8	1
11	XDOZZ	87327	20-0756	..VALVE, BALL	1
12	XDOZZ	87327	RPG04-0438	..HANDLE	1
13	XDOZZ	87327	31-0356	..PIPE, 3/8	1
14	XDOZZ	87327	24-0244	..TEE	1
15	XDOZZ	87327	05-1668	..OUTLET ADAPTER	1
16	XDOZZ	87327	05-1671	..AIR GAGE	1
17	XDOZZ	87327	24-0246	..TEE	1
18	XDOZZ	87327	20-0783	..VALVE	1
19	XDOZZ	87327	05-1669	..ADAPTER	1
20	XDOZZ	87327	05-1670	..TANK, 10GAL	1
21	XDOZZ	87327	90-0111	..DECAL	1
22	XDOZZ	87327	48-0097	..SCREW	1
23	XDOZZ	87327	05-1672	..HOSE HANGER	1
24	XDOZZ	87327	01-0681	..NUT	1
25	XDOZZ	87327	38-0202	..FACE	1
26	XDOZZ	87327	45-0071	..WASHER	1
27	XDOZZ	87327	8-0137	..SHANK	1
28	XDOZZ	87327	05-1768	..ADAPTER	1
29	XDOZZ	87327	20-0830	..FLOW CONTROL, .4GPM	1
30	XDOZZ	87327	G20-0584	..VALVE	1
31	XDOZZ	87327	G63-0022	..HOSE ASSY	1
32	XDOZZ	96906	MS90728-64	..SCREW, CAP, HEXAGON H.....	3
33	XDOZZ	96906	MS35338-46	..WASHER, LOCK.....	3
34	XDOZZ	96906	MS15795-413	..WASHER, FLAT.....	3
35	XDOZZ	81337	5-13-5056	..BRACKET, EYEWASH	3
36	XDDZZ	81337	5-4-4968	..EXPANDER	3
37	XDDZZ	81337	5-4-4930	..SLEEVE	3
38	XDOZZ	96906	MS35191-272	..SCREW, MACHINE	3
39	XDOZZ	96906	MS27130-A26	..NUT, RIVET	3

END OF FIGURE

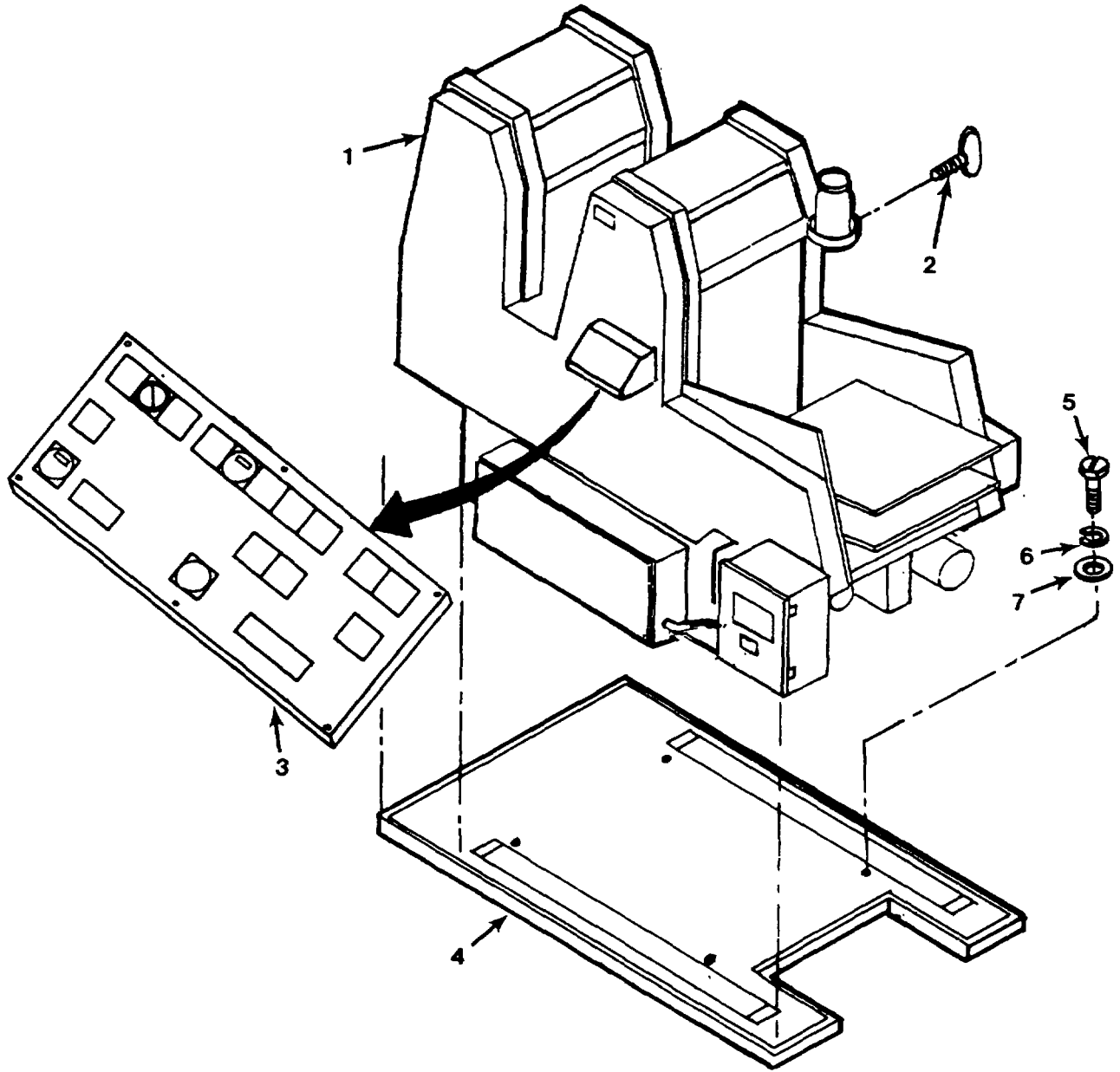

Figure 57. Printing Press Assembly

SECTION II

TM 5-3610-293-13&P

(1) ITEM NO	(2) SMR CODE	(3) CAGEC	(4) PART NUMBER	(5) DESCRIPTION AND USABLE ON CODES(UOC)	(6) QTY
GROUP 20 PRINTING PRESS					
FIG. 57 PRINTING PRESS ASSEMBLY					
	XCDDD	81337	5-13-4969	ASSY, PRESS	1
1	MDDDD	81337	5-13-4946	.PRESS, PRINTING MAKE FROM NSN 3610-.....	1
				01-259-5952, HEIDELBERG MODEL GTOZP- 52PRINTING PRESS, OFFSET, 2 COLOR, PERFECTING	
2	XDOZZ	96906	MS21316-13	.THUMBSCREW	1
3	XDDZZ	81337	5-13-4881	.PLATE, PRESS ASSY	1
4	XDDZZ	81337	5-13-4964	.PAN, DRIP, MOD	1
5	XDDZZ	96906	M590727-163	.SCREW, CAP, HEXAGON H	4
6	XDDZZ	96906	MS35338-50	.WASHER, LOCK, 5/8	4
7	XDDZZ	96906	MS15795-420	.WASHER, LOCK	4

END OF FIGURE

SECTION III

SPECIAL TOOLS LIST (NOT APPLICABLE)

SECTION IV

TM 5-3610-293-13&P

CROSS-REFERENCE INDEXES
NATIONAL STOCK NUMBER INDEX

STOCK NUMBER	FIG.	ITEM	STOCK NUMBER	FIG.	ITEM
5930-00-036-8716	24	7	5360-01-331-6404	20	4
5920-00-056-6620	41	6		30	4
5925-00-074-5750	50	1		34	4
5920-00-280-8342	37	4	4320-01-332-8509	25	1
5930-00-325-6153	41	19	5925-01-333-2419	25	8
6350-00-383-1189	39	1	4320-01-336-8163	25	2
6650-00-477-9613	17	17	4320-01-336-9207	25	3
5930-00-539-7013	24	8	4120-01-340-6032	3	1
6240-00-556-8655	17	18	4120-01-340-6033	4	1
6240-00-556-8657	41	7			
5930-00-558-6842	24	9			
5930-00-687-0553	40	8			
5925-00-728-1289	50	3			
5930-00-735-2803	37	8			
5925-00-785-4251	50	2			
5975-00-878-3791	43	6			
4210-00-889-2491	55	1			
6240-00-893-2507	37	6			
6545-00-922-1200	42	1			
4810-00-922-5464	28	12			
6210-00-944-8835	37	5			
6625-00-964-7927	37	2			
6240-01-024-6370	49	25			
5975-01-036-9575	3	13			
	4	13			
5930-01-056-5150	2	3			
6625-01-081-8850	37	9			
5920-01-087-1952	23	10			
6210-01-142-0431	44	5			
5930-01-167-7035	37	10			
5999-01-178-0168	37	15			
6685-01-188-3338	11	4			
4240-01-226-1073	56				
5930-01-233-8370	24	6			
	49	16			
7125-01-318-0312	16				
7125-01-318-0313	31				
7195-01-318-3628	22				
3610-01-319-9029	23				
6625-01-320-8929	37				
6230-01-326-0057	11	10			
	41				
4130-01-327-6293	10	5			
	10	8			
	10	34			
4540-01-328-1285	25	4			
6685-01-328-3995	23	6			
6130-01-328-6491	25	5			
6240-01-331-3410	24	4			
5360-01-331-6404	15	4			

CROSS-REFERENCE INDEXES

CAGEC	PART NUMBER	PART NUMBER INDEX		FIG.	ITEM
			STOCK NUMBER		
58536	A-A-231			23	8
58536	A-A-393		4210-00-889-2491	55	1
71400	AGC3-1/2		5920-01-087-1952	23	10
82370	A104		5975-00-878-3791	43	6
94222	A5-21-074-10			13	33
94222	A5-21-089-10			13	34
07294	CN04WCSN114		6240-00-893-2507	37	6
9R714	C808-4			6	8
9R714	C93-15			6	14
08108	FC8T9/CW		6240-00-556-8655	17	18
81349	FO2A250V1A		5920-00-280-8342	37	4
79725	G-20115			11	22
79725	G-2100B			11	18
79725	G-2100C			11	17
79725	G-2106			11	21
79725	G-2141			11	24
81348	GGG-W-641			47	1
87327	G05-0461			56	1
87327	G20-0584			56	30
5P872	G22-726		5925-01-333-2419	25	8
87327	G24-0075			56	6
87327	G63-0022			56	31
4R884	HP11-51			44	6
15806	HTAB-169		6685-01-188-3338	11	4
98003	H5371BA			13	3
				17	13
				32	10
81349	J-C-58056CK3/14S			23	12
	RSJ				
29215	JP2050-1			49	12
15607	LFMA5GY		6650-00-477-9613	17	17
81349	MIL-F-21840			38	6
				42	2
				42	3
81349	MIL-F-21840,TYPE II ,CL1			22	17
81349	MIL-F-71840,TYPE II ,CL1			22	20
81349	MIL-R-24243/3-B4 04			51	2
81349	MIL-R-24243/3B40 4			3	11
				4	11
81349	MIL-R-24243/6-A4 04H			2	9
				49	14
81349	MIL-R-24243/6-A4 05H			10	14
81349	MIL-T-55164-3			25	6
96906	MS15795-407			40	2
96906	MS15795-408			2	7

SECTION IV

TM 5-3610-293-13&P

CROSS-REFERENCE INDEXES

CAGEC	PART NUMBER	PART NUMBER INDEX		FIG.	ITEM
			STOCK NUMBER		
96906	MS15795-408			49	20
96906	MS15795-410			1	6
				3	21
				4	21
				5	5
				8	14
				10	23
				11	13
				12	4
				13	17
				15	7
				16	4
				17	9
				20	7
				23	18
				27	3
				30	7
				31	4
				34	7
				43	9
				45	15
				51	9
96906	MS15795-413			45	5
				56	34
96906	MS15795-414			14	6
				19	6
				29	6
				33	6
96906	MS15795-417			14	5
				19	5
				29	5
				33	5
96906	MS15795-420			57	7
96906	MS15795-442			11	14
				27	11
				38	10
				42	6
				45	10
				52	4
				55	4
96906	MS15795-805			3	8
				4	8
96906	MS15795-812			3	5
				4	5
96906	MS16187-11			18	9
96906	MS16556-29			15	1
				20	1
				30	1
				34	1
96906	MS16998-74			14	4
				19	4

CROSS-REFERENCE INDEXES

CAGEC	PART NUMBER	PART NUMBER INDEX		FIG.	ITEM
			STOCK NUMBER		
96906	MS16998-74			29	4
				33	4
96906	MS20470-AD6-8			54	15
96906	MS20600-B6W3			10	53
96906	MS20600-B6W5			10	58
96906	MS20600-B6W6			13	9
				18	1
96906	MS20600-MP4W6			13	2
				17	12
				22	14
				32	9
				38	4
96906	MS20600-M4W2			13	13
96906	MS20600-M4W3			13	28
96906	MSZ0601-AD4W4			8	10
96906	MS20604-B4T6			36	1
				41	8
96906	MS21316-13			57	2
96906	MS21316-23			43	4
96906	MS21316-35			17	1
96906	MS21316-36			8	1
				10	49
				13	16
				32	2
96906	MS21318-29			41	17
96906	MS24617-46			11	3
				32	17
96906	MS24630-48			3	17
				4	17
				10	1
96906	MS24693-S93			22	9
96906	MS24693-26			10	41
96906	MS24693-280			53	2
96906	MS27130-A13			8	7
				40	6
				44	4
				47	4
96906	MS27130-A19			6	2
				6	6
				32	16
				41	3
96906	MS27130-A20			2	1
96906	MS27130-A26			10	52
				56	39
96906	MS27130-A29			49	28
96906	MS27130-A3			17	3
96906	MS27130-A31			6	3
				6	5
				8	4
				13	11
				32	6

CROSS-REFERENCE INDEXES

CAGEC	PART NUMBER	PART NUMBER INDEX		FIG.	ITEM
			STOCK NUMBER		
96906	MS27130-A32			11	29
				32	12
96906	MS27130-A37			8	9
96906	MS27130-419			38	11
96906	MS27183-10			21	2
				54	3
96906	MS27734-22	5930-00-036-8716		24	7
96906	MS27735-21	5930-00-558-6842		24	9
96906	MS27735-22	5930-00-325-6153		41	19
96906	MS27736-28	5930-01-167-7035		37	10
96906	MS3368-1-0B	5975-01-036-9575		3	13
				4	13
96906	MS35140-12			49	27
96906	MS35140-14			49	7
96906	MS35140-6			43	5
96906	MS35190-287			54	6
96906	MS35191-272			49	8
				56	38
96906	MS35191-274			2	5
				42	4
				52	2
96906	MS35191-277			49	23
96906	MS35191-291			10	39
				54	9
96906	MS35191-47			6	7
96906	MS35201-263			46	1
96906	MS35206-226			37	11
96906	MS35206-243			44	1
96906	MS35206-245			8	5
				40	1
				47	2
96906	MS35206-263			32	13
				41	1
96906	MS35206-264			38	8
96906	MS35206-265			45	9
96906	MS35206-270			38	12
96906	MS35207-263			55	2
96906	MS35207-264			6	9
96906	MS35207-267			22	23
				38	14
96906	MS35333-37			10	42
96906	MS35335-33			8	2
96906	MS35338-136			3	7
				4	7
96906	MS35338-138			32	14
96906	MS35338-139			18	8
96906	MS35338-140			3	4
				4	4
96906	MS35338-40			22	10
96906	MS35338-41			37	12
96906	MS35338-42			27	7

CROSS-REFERENCE INDEXES

CAGEC	PART NUMBER	PART NUMBER INDEX		FIG.	ITEM
			STOCK NUMBER		
96906	MS35338-42			40	3
96906	MS35338-43			2	6
				27	10
				38	9
				41	2
				42	5
				45	11
				49	9
				52	3
				55	3
96906	MS35338-44			1	5
				3	20
				4	20
				5	4
				8	13
				10	22
				11	12
				12	3
				13	5
				15	8
				16	5
				17	5
				20	8
				21	4
				23	17
				27	2
				30	8
				31	5
				32	18
				34	8
				43	8
				45	14
				51	8
				54	2
96906	MS35338-46			45	4
				56	33
96906	MS35338-50			57	6
96906	MS35425-70			18	6
				43	1
				54	1
96906	MS35425-74			45	3
96906	MS35489-6			23	7
96906	MS35492			22	19
96906	MS35492-251			22	16
96906	MS35492-253			11	6
96906	MS35492-52			11	19
96906	MS35492-76			22	1
96906	MS35492-78			22	6
96906	MS35649-202			27	12
				45	12
96906	MS35649-2252			5	6

CROSS-REFERENCE INDEXES

CAGEC	PART NUMBER	PART NUMBER INDEX		FIG.	ITEM
			STOCK NUMBER		
				10	29
				13	6
				15	9
				16	6
				17	6
				18	7
				20	9
				21	5
				22	11
				23	19
				27	5
				30	9
				31	6
				34	9
96906	MS35649-2382			32	8
96906	MS35649-262			10	43
96906	MS35649-264			3	10
				4	10
96906	M535649-282			27	8
96906	MS35650-5			3	3
				4	3
96906	MS35822-9			38	7
96906	MS35842-10			28	2
96906	MS51095-303			14	2
				19	2
				29	2
				33	2
96906	MS51849-95			5	3
				15	6
				20	6
				30	6
				34	6
96906	MS51861-37			5	8
				11	1
				18	3
96906	MS51861-47			6	16
				10	11
96906	MS51861-65			17	15
96906	MS51861-67			11	27
96906	MS51862-12C			10	4
96906	MS51939-1			13	10
				51	3
96906	MS51957-30			3	6
				4	6
96906	MS51957-47			27	6
96906	MS51957-63			27	14
96906	MS51957-64			27	9
96906	MS51957-67			27	13
96906	MS51957-80			27	1
96906	MS51957-81			27	4
96906	MS51959-26			37	14

CROSS-REFERENCE INDEXES

CAGEC	PART NUMBER	PART NUMBER INDEX		FIG.	ITEM
			STOCK NUMBER		
96906	MS51959-28			27	15
96906	MS90275-8			4	19
96906	MS90725-11			11	11
96906	MS90725-13			5	7
				10	25
96906	MS90725-17			21	1
96906	MS90725-6			1	4
				6	12
				10	27
				13	4
				17	4
96906	MS90726-12			8	12
96906	MS90726-8			45	13
				51	7
96906	MS90727-163			57	5
96906	MS90728-64			56	32
96906	MS90728-8			3	19
				10	21
				12	2
				16	2
				23	16
				31	2
				43	7
81349	M16878/5BGEO			39	2
				39	3
81349	M19207/16-FHN26G			23	11
	1			37	3
81349	M24243/3B404			7	1
81349	M24243/6-A403H			39	5
81349	M5423/02-01	5930-00-539-7013		24	8
81349	M6855/1-023211			18	4
				45	2
81349	M6855/1-041211			45	7
81349	M6855/1-1012			6	11
71590	PAIOO1M	5930-00-735-2803		37	8
2R621	PA19108			13	1
53215	PD324			23	5
53215	PD324 PROBE			25	9
55719	P240			48	2
45225	P74-144			43	3
56365	QOB120	5925-00-728-1289		50	3
56365	QOB250	5925-00-074-5750		50	1
56365	QOB340	5925-00-785-4251		50	2
52359	Q674L1181			44	7
87327	RPG04-0438			56	12
87327	SE-590	4240-01-226-1073		56	
81345	UL 514AANDUL 514			11	25
12621	V778			38	3
81349	W-C-596/12-4			11	26
81349	WC596/12-4			49	17

CROSS-REFERENCE INDEXES

CAGEC	PART NUMBER	PART NUMBER INDEX		FIG.	ITEM
			STOCK NUMBER		
81348	WW-D, 1909, TY1			52	1
5P872	W69-157		4320-01-336-9207	25	3
5P872	W88-959		4320-01-336-8163	25	2
76385	Z-4023			49	24
87327	01-0632			56	5
87327	01-0681			56	24
84120	05-0065-00			38	16
87327	05-0478			56	9
87327	05-1668			56	15
87327	05-1669			56	19
87327	05-1670			56	20
87327	05-1671			56	16
87327	05-1672			56	23
87327	05-1768			56	28
87327	07-0065			56	2
18338	100653-020		5920-00-056-6620	41	6
07295	100707			41	20
55026	10220		6625-00-964-7927	37	2
23828	1138V			49	18
19207	11677011		6545-00-922-1200	42	1
56962	12PC		6240-01-331-3410	24	4
74545	1221PL		5930-01-233-8370	24	6
				49	16
39428	1224T25			10	60
25472	13-40-XKN			15	10
				20	10
				30	10
				34	10
97403	13225E3143			43	11
97403	13225E3283		5999-01-178-0168	37	15
97403	13226E4397			32	7
97403	13226E4433-1			28	4
97403	13226E4442-3			28	1
97403	13226E4508			53	1
97403	13226E4527			38	2
97403	13226E4550			28	6
97403	13226E6982-1			13	18
97403	13226E6982-2			13	19
97403	13226E6989			13	27
97403	13226E6991			13	15
				49	13
				51	4
97403	13226E7833-1			13	12
97403	13226E7834-1			13	14
97403	13226E7922			43	10
97403	13226E7945			11	9
97403	13226E7946			11	7
97403	13226E7947			11	8
97403	13226E7961			17	2
97403	13226E7965			17	7
97403	13227E			49	4

CROSS-REFERENCE INDEXES

CAGEC	PART NUMBER	PART NUMBER INDEX		FIG.	ITEM
			STOCK NUMBER		
97403	13227E5689-1			43	12
97403	13227E5689-2			43	13
97403	13227E5726-1			41	18
97403	13227E5735			43	2
97403	13227E5736			49	2
97403	13227E6253			49	3
31795	15330206			41	5
39428	1570All			22	12
39428	1664AS			10	13
39428	1676A12			22	15
03743	180-A			11	23
84570	1925-S			35	2
84570	1925-T1			35	1
16327	2V637			49	22
87327	20-0756			56	11
87327	20-0783			56	18
87327	20-0830			56	8
				56	29
32108	20F892			24	2
03350	200			49	21
39428	2069K11	4130-01-327-6293		10	5
				10	8
				10	34
66607	2088-403-444	4320-01-332-8509		25	1
79725	2100WC			11	20
79725	2151-2			49	15
83330	2220			37	7
5F993	23F5658			40	7
39428	2386T14			22	13
87327	24-0244			56	14
87327	24-0246			56	17
08556	245AL			25	7
39428	2672K13			23	15
39428	2754K1			26	2
28520	285203210			41	21
39428	2897K18			23	14
74222	30-99-142-12			10	48
56962	30095/SM2			24	3
56962	30149			24	5
63686	3058 1/2			28	9
87327	31-0292			56	10
87327	31-0356			56	13
31356	31FX60CPS	6625-01-081-8850		37	9
28520	3210			49	31
28520	3219			23	13
19557	340-4N5	6350-00-383-1189		39	1
22003	343-0001	5930-00-687-0553		40	8
39428	3656K111	4540-01-328-1285		25	4
87327	38-0202			56	25
90759	400			49	26
39428	4067K63	6685-01-328-3995		23	6

CROSS-REFERENCE INDEXES

CAGEC	PART NUMBER	PART NUMBER INDEX		FIG.	ITEM
			STOCK NUMBER		
39428	4452K434			28	8
87327	45-0071			56	26
08108	4510		6240-00-556-8657	41	7
39428	4548F171			28	7
39428	4548K176			28	13
39428	4652K23			26	1
39428	4743K1			28	10
87327	48-0097			56	22
39428	4813K81			28	17
39428	4819K14			28	11
39428	4823K14			28	14
39428	4823K18			28	16
39428	4832K14			28	15
81337	5-13-4114-1			10	3
81337	5-13-4702			51	1
81337	5-13-4703-1			31	7
81337	5-13-4703-2			23	20
81337	5-13-4703-3			12	5
81337	5-13-4703-4			16	7
81337	5-13-4704-1			33	1
81337	5-13-4704-3			14	1
81337	5-13-4704-4			19	1
81337	5-13-4704-5			29	1
81337	5-13-4705-1			33	7
81337	5-13-4705-2			29	7
81337	5-13-4705-3			14	7
81337	5-13-4705-4			19	7
81337	5-13-4708			15	5
				20	5
				30	5
				34	5
81337	5-13-4711			14	3
				19	3
				29	3
				33	3
81337	5-13-4712			13	23
				14	8
				19	8
				29	8
				33	8
81337	5-13-4713-1			4	12
81337	5-13-4713-2			3	12
81337	5-13-4715			15	2
				20	2
				30	2
				34	2
81337	5-13-4716			15	3
				20	3
				30	3
				34	3
81337	5-13-4718			51	12

CROSS-REFERENCE INDEXES

CAGEC	PART NUMBER	PART NUMBER INDEX		FIG.	ITEM
			STOCK NUMBER		
81337	5-13-4718			51	13
				51	14
				51	15
81337	5-13-4719			2	19
				2	21
81337	5-13-4720			1	3
				2	22
				2	23
				11	30
				11	31
				13	39
		47	5		
81337	5-13-4721		7195-01-318-3628	22	
81337	5-13-4722			22	2
81337	5-13-4727			22	4
81337	5-13-4728			45	1
81337	5-13-4729			45	8
81337	5-13-4730			45	6
81337	5-13-4731			22	3
81337	5-13-4732			13	31
81337	5-13-4733			3	2
81337	5-13-4734			12	1
81337	5-13-4734-4			13	8
81337	5-13-4735			13	7
81337	5-13-4736			13	26
81337	5-13-4737			13	38
81337	5-13-4738			13	25
81337	5-13-4740			12	
81337	5-13-4742			13	30
81337	5-13-4743			13	29
81337	5-13-4744			13	35
81337	5-13-4745			13	36
81337	5-13-4746			16	1
81337	5-13-4746-15			17	14
81337	5-13-4747			17	10
81337	5-13-4750			17	8
81337	5-13-4752			17	11
81337	5-13-4753-1			18	5
81337	5-13-4753-2			18	11
81337	5-13-4754			18	10
81337	5-13-4755			18	2
81337	5-13-4756			17	16
81337	5-13-4757			17	20
81337	5-13-4758			13	22
				14	10
				19	10
				29	10
				33	10
				13	24
81337	5-13-4759			14	9
				19	9

CROSS-REFERENCE INDEXES

CAGEC	PART NUMBER	PART NUMBER INDEX		FIG.	ITEM
			STOCK NUMBER		
81337	5-13-4759			29	9
				33	9
81337	5-13-4760			16	3
81337	5-13-4761			17	22
81337	5-13-4762			31	1
81337	5-13-4763			4	2
81337	5-13-4764			32	19
81337	5-13-4768			32	4
81337	5-13-4769			32	15
81337	5-13-4773			32	11
81337	5-13-4774-1			22	7
81337	5-13-4774-2			22	8
81337	5-13-4775			38	1
81337	5-13-4776			38	5
81337	5-13-4777			42	7
81337	5-13-4780	6230-01-326-0057		11	10
				41	
81337	5-13-4780-15			41	16
81337	5-13-4781			41	4
81337	5-13-4782-1			41	9
81337	5-13-4782-1-1			41	11
81337	5-13-4782-1-4			41	10
81337	5-13-4782-2			41	12
81337	5-13-4782-2-1			41	14
81337	5-13-4782-2-4			41	13
81337	5-13-4783			41	15
81337	5-13-4784	6625-01-320-8929		37	
81337	5-13-4785			37	1
81337	5-13-4789			39	
81337	5-13-4793			23	1
81337	5-13-4796			23	22
81337	5-13-4797			23	21
81337	5-13-4799			23	25
81337	5-13-4800			23	23
81337	5-13-4801			23	24
81337	5-13-4803			28	
81337	5-13-4806			25	11
81337	5-13-4810			23	9
81337	5-13-4811			25	12
81337	5-13-4812			23	3
81337	5-13-4815			23	2
81337	5-13-4822			2	20
				3	24
				4	24
				10	35
				10	63
				10	64
				13	20
				13	21
				35	3
				51	16

CROSS-REFERENCE INDEXES

CAGEC	PART NUMBER	PART NUMBER INDEX		FIG.	ITEM
			STOCK NUMBER		
81337	5-13-4822			51	17
				51	18
				51	19
81337	5-13-4823			13	37
81337	5-13-4826		7125-01-318-0312	16	
81337	5-13-4827			32	3
81337	5-13-4827-3			32	5
81337	5-13-4828		7125-01-318-0313	31	
81337	5-13-4829			22	5
81337	5-13-4829-6			22	18
81337	5-13-4830			45	
81337	5-13-4832-16			17	21
81337	5-13-4833			17	19
81337	5-13-4834			17	
81337	5-13-4835			31	3
81337	5-13-4846-1			37	16
81337	5-13-4846-2			37	17
81337	5-13-4846-3			37	18
81337	5-13-4846-4			37	19
81337	5-13-4846-5			37	20
81337	5-13-4846-6			37	21
81337	5-13-4846-7			37	22
81337	5-13-4846-8			37	23
81337	5-13-4846-9			37	24
81337	5-13-4881			57	3
81337	5-13-4888			11	
81337	5-13-4889			10	
81337	5-13-4889-44			10	12
81337	5-13-4890			10	38
81337	5-13-4891			10	20
81337	5-13-4892			10	18
81337	5-13-4893			10	32
81337	5-13-4894			10	19
81337	5-13-4895			10	17
81337	5-13-4896			10	28
81337	5-13-4897			10	45
81337	5-13-4898			10	44
81337	5-13-4900		4120-01-340-6032	3	1
81337	5-13-4900-17			3	14
81337	5-13-4901			10	37
81337	5-13-4902			10	30
81337	5-13-4904		4120-01-340-6033	4	1
81337	5-13-4904-17			4	14
81337	5-13-4905			10	31
81337	5-13-4907			49	
81337	5-13-4908			10	46
81337	5-13-4911			10	36
81337	5-13-4912			10	40
81337	5-13-4913-1			11	28
81337	5-13-4914-2			10	2
81337	5-13-4916-2			10	33

CROSS-REFERENCE INDEXES

CAGEC	PART NUMBER	PART NUMBER INDEX		FIG.	ITEM
			STOCK NUMBER		
81337	5-13-4917-1			10	6
81337	5-13-4917-2			10	9
81337	5-13-4918-1			10	7
81337	5-13-4918-2			10	10
81337	5-13-4919			10	26
81337	5-13-4921			24	1
81337	5-13-4922			5	1
81337	5-13-4923			8	3
81337	5-13-4927-1			3	15
81337	5-13-4927-2			4	15
81337	5-13-4930			3	18
81337	5-13-4931			4	18
81337	5-13-4932			3	22
81337	5-13-4936			4	22
81337	5-13-4940			5	2
81337	5-13-4941			23	4
81337	5-13-4942		3610-01-319-9029	23	
81337	5-13-4943			25	14
81337	5-13-4944			25	13
81337	5-13-4945			25	15
81337	5-13-4946			57	1
81337	5-13-4950			42	
81337	5-13-4954			6	17
81337	5-13-4955			6	18
81337	5-13-4956			6	13
81337	5-13-4957-1			6	19
81337	5-13-4957-2			6	20
81337	5-13-4958			7	2
81337	5-13-4959			6	10
81337	5-13-4960			7	3
81337	5-13-4962			6	
81337	5-13-4963			8	
81337	5-13-4964			57	4
81337	5-13-4966			6	1
81337	5-13-4967			6	4
81337	5-13-4968			2	
81337	5-13-4969			57	
81337	5-13-4972			11	2
				44	
81337	5-13-4973			25	16
				44	3
81337	5-13-4974			44	2
81337	5-13-4976			44	8
81337	5-13-4977			43	
81337	5-13-4980			49	29
81337	5-13-4988			46	2
81337	5-13-4989			40	5
81337	5-13-4990			40	4
81337	5-13-4992			1	1
81337	5-13-4994			2	17
81337	5-13-4995			2	13

CROSS-REFERENCE INDEXES

CAGEC	PART NUMBER	PART NUMBER INDEX		FIG.	ITEM
			STOCK NUMBER		
81337	5-13-4996			2	10
81337	5-13-4998			2	11
81337	5-13-4999			2	15
81337	5-13-5000			47	
81337	5-13-5003			22	24
81337	5-13-5004			22	25
81337	5-13-5005			11	5
81337	5-13-5006			2	8
81337	5-13-5007			2	2
81337	5-13-5008			2	4
81337	5-13-5011			5	9
81337	5-13-5013			49	11
81337	5-13-5014			2	18
81337	5-13-5015			2	14
81337	5-13-5016			38	15
81337	5-13-5020			1	2
81337	5-13-5021			10	55
81337	5-13-5024			36	
81337	5-13-5026			36	2
81337	5-13-5027			38	13
81337	5-13-5028			36	3
81337	5-13-5031-1			4	9
81337	5-13-5031-2			3	9
81337	5-13-5032			1	7
81337	5-13-5033			48	
81337	5-13-5036			35	
81337	5-13-5040			10	56
81337	5-13-5042			10	54
81337	5-13-5043			10	59
81337	5-13-5044			10	61
81337	5-13-5045			10	62
81337	5-13-5046			10	57
81337	5-13-5051			22	22
81337	5-13-5052-2			22	21
81337	5-13-5053			8	16
81337	5-13-5054			8	15
81337	5-13-5055			8	19
81337	5-13-5056			56	35
81337	5-13-5063			36	4
81337	5-13-5064			10	50
81337	5-4-2954			9	1
81337	5-4-3019			8	11
81337	5-4-3042			2	12
				2	16
81337	5-4-3050			48	1
81337	5-4-4831			8	18
				45	17
				51	11
				54	12
81337	5-4-4928			38	18
				42	9

CROSS-REFERENCE INDEXES

CAGEC	PART NUMBER	PART NUMBER INDEX		FIG.	ITEM
			STOCK NUMBER		
81337	5-4-4928			49	30
				52	6
				53	4
				55	6
81337	5-4-4930			51	6
				56	37
81337	5-4-4934			8	17
				45	16
				51	10
81337	5-4-4935			54	11
				38	17
				42	8
				52	5
				53	3
81337	5-4-4968			55	5
				51	5
81337	5-4-4984			56	36
				49	19
81337	5-4-5106			8	6
81337	5-4-5107			47	3
				8	8
82685	5K809			10	15
72619	508-8738-504	6210-01-142-0431		10	16
72619	508-8745-504	6210-00-944-8835		44	5
88204	52A/SS	6240-01-024-6370		37	5
39428	5266K59			49	25
39428	5373K25			10	51
39428	5373K73			28	3
96906	5975-00-995-2168			28	5
81337	6-1-5888-2			49	1
81337	6-1-7503-17			39	4
81337	6-1-7539			21	9
81337	6-1-7543			21	6
81337	6-1-7543-1			54	
81337	6-1-7543-2			54	10
81337	6-1-7543-3			54	4
81337	6-1-7543-4			54	16
81337	6-1-7543-5			54	8
81337	6-1-7543-6			54	7
81337	6-1-7543-7			54	13
81337	6-1-7543-8			54	14
81337	6-1-7547-6			54	5
42689	60-016-24TYPEF			21	3
2R621	627			21	8
42689	68-090			32	1
39428	7119K12			21	7
39428	7119K21			49	5
39428	7127K25			49	10
87327	8-0116			49	6
87327	8-0137			56	3
				56	27

SECTION IV

TM 5-3610-293-13&P

CROSS-REFERENCE INDEXES

CAGEC	PART NUMBER	PART NUMBER INDEX		FIG.	ITEM
			STOCK NUMBER		
87327	8-0234			56	4
87327	8-0275			56	7
09353	8168		5930-01-056-5150	2	3
04845	8210D2		4810-00-922-5464	28	12
2R182	8345			37	13
55814	86-12-312		6130-01-328-6491	25	5
39428	8614K23			3	16
				4	16
87327	90-0111			56	21
39428	90975A029			10	24
				10	47
				11	15
94222	92-20-305-72			13	32
39428	9326K5			25	10
39428	9350K1			6	15
39428	9385K21			3	23
				4	23
39428	9417K4			11	16
39428	9620K24		5360-01-331-6404	15	4
				20	4
				30	4
				34	4
39428	9775K21			26	3

CROSS-REFERENCE INDEXES

FIGURE AND ITEM NUMBER INDEX

FIG.	ITEM	STOCK NUMBER	CAGEC	PART NUMBER
1	1		81337	5-13-4992
1	2		81337	5-13-5020
1	3		81337	5-13-4720
1	4		96906	MS90725-6
1	5		96906	MS35338-44
1	6		96906	MS15795-410
1	7		81337	5-13-5032
2			81337	5-13-4968
2	1		96906	MS27130-A20
2	2		81337	5-13-5007
2	3	5930-01-056-5150	09353	8168
2	4		81337	5-13-5008
2	5		96906	MS35191-274
2	6		96906	MS35338-43
2	7		96906	MS15795-408
2	8		81337	5-13-5006
2	9		81349	MIL-R-24243/6-A4 04H
2	10		81337	5-13-4996
2	11		81337	5-13-4998
2	12		81337	5-4-3042
2	13		81337	5-13-4995
2	14		81337	5-13-5015
2	15		81337	5-13-4999
2	16		81337	5-4-3042
2	17		81337	5-13-4994
2	18		81337	5-13-5014
2	19		81337	5-13-4719
2	20		81337	5-13-4822
2	21		81337	5-13-4719
2	22		81337	5-13-4720
2	23		81337	5-13-4720
3	1	4120-01-340-6032	81337	5-13-4900
3	2		81337	5-13-4733
3	3		96906	MS35650-5
3	4		96906	MS35338-140
3	5		96906	MS15795-812
3	6		96906	MS51957-30
3	7		96906	MS35338-136
3	8		96906	MS15795-805
3	9		81337	5-13-5031-2
3	10		96906	MS35649-264
3	11		81349	MIL-R-24243/3B40 4
3	12		81337	5-13-4713-2
3	13	5975-01-036-9575	96906	MS3368-1-0B
3	14		81337	5-13-4900-17
3	15		81337	5-13-4927-1
3	16		39428	8614K23
3	17		96906	M524630-48
3	18		81337	5-13-4930

CROSS-REFERENCE INDEXES

FIGURE AND ITEM NUMBER INDEX

FIG.	ITEM	STOCK NUMBER	CAGEC	PART NUMBER
3	19		96906	MS90728-8
3	20		96906	MS35338-44
3	21		96906	MS15795-410
3	22		81337	5-13-4932
3	23		39428	9385K21
3	24		81337	5-13-4822
4	1	4120-01-340-6033	81337	5-13-4904
4	2		81337	5-13-4763
4	3		96906	MS35650-5
4	4		96906	MS35338-140
4	5		96906	MS15795-812
4	6		96906	MS51957-30
4	7		96906	MS35333-136
4	8		96906	MS15795-805
4	9		81337	5-13-5031-1
4	10		96906	tIS35649-264
4	11		81349	MIL-R-24243/3B40 4
4	12		81337	5-13-4713-1
4	13	5975-01-036-9575	96906	MS3368-1-0B
4	14		81337	5-13-4904-17
4	15		81337	5-13-4927-2
4	16		39428	8614K23
4	17		96906	MS24630-48
4	18		81337	5-13-4931
4	19		96906	MS90275-8
4	20		96906	MS35338-44
4	21		96906	MS15795-410
4	22		81337	5-13-4936
4	23		39428	9385K21
4	24		81337	5-13-4822
5	1		81337	5-13-4922
5	2		81337	5-13-4940
5	3		96906	MS51849-95
5	4		96906	MS353338-44
5	5		96906	MS15795-410
5	6		96906	MS35649-2252
5	7		96906	MS90725-13
5	8		96906	MS51861-37
5	9		81337	5-13-5011
6			81337	5-13-4962
6	1		81337	5-13-4966
6	2		96906	MS27130-A19
6	3		96906	MS27130-A31
6	4		81337	5-13-4967
6	5		96906	MS27130-A31
6	6		96906	MS27130-A19
6	7		96906	MS35191-47
6	8		9R714	C808-4
6	9		96906	MS35207-264
6	10		81337	5-13-4959

CROSS-REFERENCE INDEXES

FIGURE AND ITEM NUMBER INDEX

FIG.	ITEM	STOCK NUMBER	CAGEC	PART NUMBER
6	11		81349	M6855/1-1012
6	12		96906	NS90725-6
6	13		81337	5-13-4956
6	14		9R714	C93-15
6	15		39428	9350K1
6	16		96906	MS51861-47
6	17		81337	5-13-4954
6	18		81337	5-13-4955
6	19		81337	5-13-4957-1
6	20		81337	5-13-4957-2
7	1		81349	M24243/3B404
7	2		81337	5-13-4958
7	3		81337	5-13-4960
8			81337	5-13-4963
8	1		96906	MS21316-36
8	2		96906	MS35335-33
8	3		81337	5-13-4923
8	4		96906	MS27130-A31
8	5		96906	MS35206-245
8	6		81337	5-4-5106
8	7		96906	MS27130-A13
8	8		81337	5-4-5107
8	9		96906	MS27130-A37
8	10		96906	MS20601-AD4W4
8	11		81337	5-4-3019
8	12		96906	MS90726-12
8	13		96906	MS35338-44
8	14		96906	MS15795-410
8	15		81337	5-13-5054
8	16		81337	5-13-5053
8	17		81337	5-4-4934
8	18		81337	5-4-4831
8	19		81337	5-13-5055
9	1		81337	5-4-2954
10			81337	5-13-4889
10	1		96906	MS24630-48
10	2		81337	5-13-4914-2
10	3		81337	5-13-4114-1
10	4		96906	MS51862-12C
10	5	4130-01-327-6293	39428	2069K11
10	6		81337	5-13-4917-1
10	7		81337	5-13-4918-1
10	8	4130-01-327-6293	39428	2069K11
10	9		81337	5-13-4917-2
10	10		81337	5-13-4918-2
10	11		96906	MS51861-47
10	12		81337	5-13-4889-44
10	13		39428	1664AS
10	14		81349	MIL-R-24243/6-A4
10				05H
10	15		82685	5K809

CROSS-REFERENCE INDEXES

FIGURE AND ITEM NUMBER INDEX

FIG.	ITEM	STOCK NUMBER	CAGEC	PART NUMBER
10	16		82685	5K809
10	17		81337	5-13-4895
10	18		81337	5-13-4892
10	19		81337	5-13-4894
10	20		81337	5-13-4891
10	21		96906	MS90728-8
10	22		96906	MS35338-44
10	23		96906	MS15795-410
10	24		39428	90975A029
10	25		96906	MS90725-13
10	26		81337	5-13-4919
10	27		96906	MS90725-6
10	28		81337	5-13-4896
10	29		96906	MS35649-2252
10	30		81337	5-13-4902
10	31		81337	5-13-4905
10	32		81337	5-13-4893
10	33		81337	5-13-4916-2
10	34	4130-01-327-6293	39428	2069K11
10	35		81337	5-13-4822
10	36		81337	5-13-4911
10	37		81337	5-13-4901
10	38		81337	5-13-4890
10	39		96906	MS35191-291
10	40		81337	5-13-4912
10	41		96906	MS24693-26
10	42		96906	MS35333-37
10	43		96906	MS35649-262
10	44		81337	5-13-4898
10	45		81337	5-13-4897
10	46		81337	5-13-4908
10	47		39428	90975A029
10	48		74222	30-99-142-12
10	49		96906	MS21316-36
10	50		81337	5-13-5064
10	51		39428	5266K59
10	52		96906	MS27130-A26
10	53		96906	MS20600-B6W3
10	54		81337	5-13-5042
10	55		81337	5-13-5021
10	56		81337	5-13-5040
10	57		81337	5-13-5046
10	58		96906	MS20600-B6W5
10	59		81337	5-13-5043
10	60		39428	1224T25
10	61		81337	5-13-5044
10	62		81337	5-13-5045
10	63		81337	5-13-4822
10	64		81337	5-13-4822
11			81337	5-13-4888
11	1		96906	MS51861-37

CROSS-REFERENCE INDEXES

FIGURE AND ITEM NUMBER INDEX

FIG.	ITEM	STOCK NUMBER	CAGEC	PART NUMBER
11	2		81337	5-13-4972
11	3		96906	MS24617-46
11	4	6685-01-188-3338	15806	HTAB-169
11	5		81337	5-13-5005
11	6		96906	MS35492-253
11	7		97403	13226E7946
11	8		97403	13226E7947
11	9		97403	13226E7945
11	10	6230-01-326-0057	81337	5-13-4780
11	11		96906	MS90725-11
11	12		96906	MS35338-44
11	13		96906	MS15795-410
11	14		96906	MS15795-442
11	15		39428	90975A029
11	16		39428	9417K4
11	17		79725	G-2100C
11	18		79725	G-2100B
11	19		96906	MS35492-52
11	20		79725	2100WC
11	21		79725	G-2106
11	22		79725	G-20115
11	23		03743	180-A
11	24		79725	G-2141
11	25		81345	UL 514AANDUL 514
11	26		81349	W-C-596/12-4
11	27		96906	MS51861-67
11	28		81337	5-13-4913-1
11	29		96906	MS27130-A32
11	30		81337	5-13-4720
11	31		81337	5-13-4720
12			81337	5-13-4740
12	1		81337	5-13-4734
12	2		96906	MS90728-8
12	3		96906	MS35338-44
12	4		96906	MS15795-410
12	5		81337	5-13-4703-3
13	1		2R621	PA19108
13	2		96906	MS20600-MP4W6
13	3		98003	H5371BA
13	4		96906	MS90725-6
13	5		96906	MS35338-44
13	6		96906	MS35649-2252
13	7		81337	5-13-4735
13	8		81337	5-13-4734-4
13	9		96906	MS20600-B6W6
13	10		96906	MS51939-1
13	11		96906	MS27130-A31
13	12		97403	13226E7833-1
13	13		96906	MSZ20600-M14W2
13	14		97403	13226E7834-1
13	15		97403	13226E6991

CROSS-REFERENCE INDEXES

FIGURE AND ITEM NUMBER INDEX

FIG.	ITEM	STOCK NUMBER	CAGEC	PART NUMBER
13	16		96906	MS21316-36
13	17		96906	M515795-410
13	18		97403	13226E6982-1
13	19		97403	13226E6982-2
13	20		81337	5-13-4822
13	21		81337	5-13-4822
13	22		81337	5-13-4758
13	23		81337	5-13-4712
13	24		81337	5-13-4759
13	25		81337	5-13-4738
13	26		81337	5-13-4736
13	27		97403	13226E6989
13	28		96906	MS20600-M4W3
13	29		81337	5-13-4743
13	30		81337	5-13-4742
13	31		81337	5-13-4732
13	32		94222	92-20-305-72
13	33		94222	A5-21-074-10
13	34		94222	A5-21-089-10
13	35		81337	5-13-4744
13	36		81337	5-13-4745
13	37		81337	5-13-4823
13	38		81337	5-13-4737
13	39		81337	5-13-4720
14	1		81337	5-13-4704-3
14	2		96906	MS51095-303
14	3		81337	5-13-4711
14	4		96906	MS16998-74
14	5		96906	MS15795-417
14	6		96906	MS15795-414
14	7		81337	5-13-4705-3
14	8		81337	5-13-4712
14	9		81337	5-13-4759
14	10		81337	5-13-4758
15	1		96906	MS16556-29
15	2		81337	5-13-4715
15	3		81337	5-13-4716
15	4	5360-01-331-6404	39428	9620K24
15	5		81337	5-13-4708
15	6		96906	MS51849-95
15	7		96906	MS15795-410
15	8		96906	MS35338-44
15	9		96906	MS35649-2252
15	10		25472	13-40-XKN
16		7125-01-318-0312	81337	5-13-4826
16	1		81337	5-13-4746
16	2		96906	MS90728-8
16	3		81337	5-13-4760
16	4		96906	MS15795-410
16	5		96906	MS35338-44
16	6		96906	MS35649-2252

CROSS-REFERENCE INDEXES

FIGURE AND ITEM NUMBER INDEX

FIG.	ITEM	STOCK NUMBER	CAGEC	PART NUMBER
16	7		81337	5-13-4703-4
17			81337	5-13-4834
17	1		96906	M521316-35
17	2		97403	13226E7961
17	3		96906	MS27130-A3
17	4		96906	MS90725-6
17	5		96906	MS35338-44
17	6		96906	MS35649-2252
17	7		97403	13226E7965
17	8		81337	5-13-4750
17	9		96906	MS15795-410
17	10		81337	5-13-4747
17	11		81337	5-13-4752
17	12		96906	MS20600-MP4W6
17	13		98003	H5371BA
17	14		81337	5-13-4746-15
17	15		96906	MS51861-65
17	16		81337	5-13-4756
17	17	6650-00-477-9613	15607	LFMA5GY
17	18	6240-00-556-8655	08108	FC8T9/CW
17	19		81337	5-13-4833
17	20		81337	5-13-4757
17	21		81337	5-13-4832-16
17	22		81337	5-13-4761
18	1		96906	MS20600-B6W6
18	2		81337	5-13-4755
18	3		96906	MS51861-37
18	4		81349	M6855/1-023211
18	5		81337	5-13-4753-1
18	6		96906	MS35425-70
18	7		96906	MS35649-2252
18	8		96906	MS35338-139
18	9		96906	MS16187-11
18	10		81337	5-13-4754
18	11		81337	5-13-4753-2
19	1		81337	5-13-4704-4
19	2		96906	MS51095-303
19	3		81337	5-13-4711
19	4		96906	MS16998-74
19	5		96906	MS15795-417
19	6		96906	MS15795-414
19	7		81337	5-13-4705-4
19	8		81337	5-13-4712
19	9		81337	5-13-4759
19	10		81337	5-13-4758
20	1		96906	MS16556-29
20	2		81337	5-13-4715
20	3		81337	5-13-4716
20	4	5360-01-331-6404	39428	9620K24
20	5		81337	5-13-4708
20	6		96906	MS51849-95

CROSS-REFERENCE INDEXES

FIGURE AND ITEM NUMBER INDEX

FIG.	ITEM	STOCK NUMBER	CAGEC	PART NUMBER
20	7		96906	MS15795-410
20	8		96906	MS35338-44
20	9		96906	MS35649-2252
20	10		25472	13-40-XKN
21	1		96906	MS90725-17
21	2		96906	MS27183-10
21	3		81337	6-1-7547-6
21	4		96906	MS35338-44
21	5		96906	MS35649-2252
21	6		81337	6-1-7539
21	7		42689	68-090
21	8		42689	60-016-24TYPEF
21	9		81337	6-1-7503-17
22		7195-01-318-3628	81337	5-13-4721
22	1		96906	MS35492-76
22	2		81337	5-13-4722
22	3		81337	5-13-4731
22	4		81337	5-13-4727
22	5		81337	5-13-4829
22	6		96906	MS35492-78
22	7		81337	5-13-4774-1
22	8		81337	5-13-4774-2
22	9		96906	MS24693-S93
22	10		96906	MS35338-40
22	11		96906	MS35649-2252
22	12		39428	1570A11
22	13		39428	2386T14
22	14		96906	MS20600-MP4W6
22	15		39428	1676A12
22	16		96906	MS35492-251
22	17		81349	MIL-F-21840,TYPE II, CL1
22	18		81337	5-13-4829-6
22	19		96906	MS35492
22	20		81349	MIL-F-71840,TYPE II, CL1
22	21		81337	5-13-5052-2
22	22		81337	5-13-5051
22	23		96906	MS35207-267
22	24		81337	5-13-5003
22	25		81337	5-13-5004
23		3610-01-319-9029	81337	5-13-4942
23	1		81337	5-13-4793
23	2		81337	5-13-4815
23	3		81337	5-13-4812
23	4		81337	5-13-4941
23	5		53215	PD324
23	6	6685-01-328-3995	39428	4067K63
23	7		96906	MS35489-6
23	8		58536	A-A-231
23	9		81337	5-13-4810

CROSS-REFERENCE INDEXES

FIGURE AND ITEM NUMBER INDEX

FIG.	ITEM	STOCK NUMBER	CAGEC	PART NUMBER
23	10	5920-01-087-1952	71400	AGC3-1/2
23	11		81349	M19207/16-FHN26G 1
23	12		81349	J-C-58056CK3/14S RSJ
23	13		28520	3219
23	14		39428	2897K18
23	15		39428	2672K13
23	16		96906	MS90728-8
23	17		96906	MS35338-44
23	18		96906	MS15795-410
23	19		96906	MS35649-2252
23	20		81337	5-13-4703-2
23	21		81337	5-13-4797
23	22		81337	5-13-4796
23	23		81337	5-13-4800
23	24		81337	5-13-4801
23	25		81337	5-13-4799
24	1		81337	5-13-4921
24	2		32108	20F892
24	3		56962	30095/SM2
24	4	6240-01-331-3410	56962	12PC
24	5		56962	30149
24	6	5930-01-233-8370	74545	1221PL
24	7	5930-00-036-8716	96906	MS27734-22
24	8	5930-00-539-7013	81349	M5423/02-01
24	9	5930-00-558-6842	96906	MS27735-21
25	1	4320-01-332-8509	66607	2088-403-444
25	2	4320-01-336-8163	5P872	W88-959
25	3	4320-01-336-9207	5P872	W69-157
25	4	4540-01-328-1285	39428	3656K111
25	5	6130-01-328-6491	55814	86-12-312
25	6		81349	MIL-T-55164-3
25	7		08556	245AL
25	8	5925-01-333-2419	5P872	G22-726
25	9		53215	PD324 PROBE
25	10		39428	9326K5
25	11		81337	5-13-4806
25	12		81337	5-13-4811
25	13		81337	5-13-4944
25	14		81337	5-13-4943
25	15		81337	5-13-4945
25	16		81337	5-13-4973
26	1		39428	4652K23
26	2		39428	2754K1
26	3		39428	9775K21
27	1		96906	MS51957-80
27	2		96906	MS35338-44
27	3		96906	MS15795-410
27	4		96906	MS51957-81
27	5		96906	MS35649-2252

CROSS-REFERENCE INDEXES

FIGURE AND ITEM NUMBER INDEX

FIG.	ITEM	STOCK NUMBER	CAGEC	PART NUMBER
27	6		96906	MS551957-47
27	7		96906	MS35338-42
27	8		96906	MS35649-282
27	9		96906	MS51957-64
27	10		96906	MS35338-43
27	11		96906	MS15795-442
27	12		96906	MS35649-202
27	13		96906	MS551957-67
27	14		96906	MS51957-63
27	15		96906	MS51959-28
28			81337	5-13-4803
28	1		97403	13226E4442-3
28	2		96906	M535842-10
28	3		39428	5373K25
28	4		97403	13226E4433-1
28	5		39428	5373K73
28	6		97403	13226E4550
28	7		39428	4548F171
28	8		39428	4452K434
28	9		63686	3058 1/2
28	10		39428	4743K1
28	11		39428	4819K14
28	12	4810-00-922-5464	04845	8210D2
28	13		39428	4548K176
28	14		39428	4823K14
28	15		39428	4832K14
28	16		39428	4823K18
28	17		39428	4813K81
29	1		81337	5-13-4704-5
29	2		96906	MS51095-303
29	3		81337	5-13-4711
29	4		96906	MS16998-74
29	5		96906	MS15795-417
29	6		96906	MS15795-414
29	7		81337	5-13-4705-2
29	8		81337	5-13-4712
29	9		81337	5-13-4759
29	10		81337	5-13-4758
30	1		96906	M516556-29
30	2		81337	5-13-4715
30	3		81337	5-13-4716
30	4	5360-01-331-6404	39428	9620K24
30	5		81337	5-13-4708
30	6		96906	MS51849-95
30	7		96906	MS15795-410
30	8		96906	MS35338-44
30	9		96906	MS35649-2252
30	10		25472	13-40-XKN
31		7125-01-318-0313	81337	5-13-4828
31	1		81337	5-13-4762
31	2		96906	MS90728-8

CROSS-REFERENCE INDEXES

FIGURE AND ITEM NUMBER INDEX

FIG.	ITEM	STOCK NUMBER	CAGEC	PART NUMBER
31	3		81337	5-13-4835
31	4		96906	MS15795-410
31	5		96906	MS35338-44
31	6		96906	MS35649-2252
31	7		81337	5-13-4703-1
32	1		2R621	627
32	2		96906	MS21316-36
32	3		81337	5-13-4827
32	4		81337	5-13-4768
32	5		81337	5-13-4827-3
32	6		96906	MS27130-A31
32	7		97403	13226E4397
32	8		96906	MS35649-2382
32	9		96906	MS20600-MP4W6
32	10		98003	H5371BA
32	11		81337	5-13-4773
32	12		96906	MS27130-A32
32	13		96906	MS35206-263
32	14		96906	MS35338-138
32	15		81337	5-13-4769
32	16		96906	MS27130-A19
32	17		96906	MS24617-46
32	18		96906	MS35338-44
32	19		81337	5-13-4764
33	1		81337	5-13-4704-1
33	2		96906	MS51095-303
33	3		81337	5-13-4711
33	4		96906	MS16998-74
33	5		96906	MS15795-417
33	6		96906	MS15795-414
33	7		81337	5-13-4705-1
33	8		81337	5-13-4712
33	9		81337	5-13-4759
33	10		81337	5-13-4758
34	1		96906	MS16556-29
34	2		81337	5-13-4715
34	3		81337	5-13-4716
34	4	5360-01-331-6404	39428	9620K24
34	5		81337	5-13-4708
34	6		96906	MS51849-95
34	7		96906	MS15795-410
34	8		96906	MS35338-44
34	9		96906	MS35649-2252
34	10		25472	13-40-XKN
35			81337	5-13-5036
35	1		84570	1925-T1
35	2		84570	1925-S
35	3		81337	5-13-4822
36			81337	5-13-5024
36	1		96906	MS20604-B4T6
36	2		81337	5-13-5026

CROSS-REFERENCE INDEXES

FIGURE AND ITEM NUMBER INDEX

FIG.	ITEM	STOCK NUMBER	CAGEC	PART NUMBER
36	3		81337	5-13-5028
36	4		81337	5-13-5063
37		6625-01-320-8929	81337	5-13-4784
37	1		81337	5-13-4785
37	2	6625-00-964-7927	55026	10220
37	3		81349	M19207/16-FHN26G 1
37	4	5920-00-280-8342	81349	FO2A250V1A
37	5	6210-00-944-8835	72619	508-8745-504
37	6	6240-00-893-2507	07294	CN04WCSN114
37	7		83330	2220
37	8	5930-00-735-2803	71590	PA1001M
37	9	6625-01-081-8850	31356	31FX60CPS
37	10	5930-01-167-7035	96906	MS27736-28
37	11		96906	MS35206-226
37	12		96906	MS35338-41
37	13		2R182	8345
37	14		96906	MS51959-26
37	15	5999-01-178-0168	97403	13225E3283
37	16		81337	5-13-4846-1
37	17		81337	5-13-4846-2
37	18		81337	5-13-4846-3
37	19		81337	5-13-4846-4
37	20		81337	5-13-4846-5
37	21		81337	5-13-4846-6
37	22		81337	5-13-4846-7
37	23		81337	5-13-4846-8
37	24		81337	5-13-4846-9
38	1		81337	5-13-4775
38	2		97403	13226E4527
38	3		12621	V778
38	4		96906	MS20600-MP4W6
38	5		81337	5-13-4776
38	6		81349	MIL-F-21840
38	7		96906	MS35822-9
38	8		96906	MS35206-264
38	9		96906	MS35338-43
38	10		96906	MS15795-442
38	11		96906	MS27130-419
38	12		96906	M535206-270
38	13		81337	5-13-5027
38	14		96906	MS35207-267
38	15		81337	5-13-5016
38	16		84120	05-0065-00
38	17		81337	5-4-4935
38	18		81337	5-4-4928
39			81337	5-13-4789
39	1	6350-00-383-1189	19557	340-4N5
39	2		81349	M16878/5BGEO
39	3		81349	M16878/5BGEO
39	4		81337	6-1-5888-2

CROSS-REFERENCE INDEXES

FIGURE AND ITEM NUMBER INDEX

FIG.	ITEM	STOCK NUMBER	CAGEC	PART NUMBER
39	5		81349	M24243/6-A403H
40	1		96906	MS35206-245
40	2		96906	MS15795-407
40	3		96906	MS35338-42
40	4		81337	5-13-4990
40	5		81337	5-13-4989
40	6		96906	MS27130-A13
40	7		5F993	23F5658
40	8	5930-00-687-0553	22003	343-0001
41		6230-01-326-0057	81337	5-13-4780
41	1		96906	MS35206-263
41	2		96906	MS35338-43
41	3		96906	MS27130-A19
41	4		81337	5-13-4781
41	5		31795	15330206
41	6	5920-00-056-6620	18338	100653-020
41	7	6240-00-556-8657	08108	4510
41	8		96906	MS20604-B4T6
41	9		81337	5-13-4782-1
41	10		81337	5-13-4782-1-4
41	11		81337	5-13-4782-1-1
41	12		81337	5-13-4782-2
41	13		81337	5-13-4782-2-4
41	14		81337	5-13-4782-2-1
41	15		81337	5-13-4783
41	16		81337	5-13-4780-15
41	17		96906	MS21318-29
41	18		97403	13227E5726-1
41	19	5930-00-325-6153	96906	MS27735-22
41	20		07295	100707
41	21		28520	285203210
42			81337	5-13-4950
42	1	6545-00-922-1200	19207	11677011
42	2		81349	MIL-F-21840
42	3		81349	MIL-F-21840
42	4		96906	MS35191-274
42	5		96906	MS35338-43
42	6		96906	MS15795-442
42	7		81337	5-13-4777
42	8		81337	5-4-4935
42	9		81337	5-4-4928
43			81337	5-13-4977
43	1		96906	MS35425-70
43	2		97403	13227E5735
43	3		45225	P74-144
43	4		96906	MS21316-23
43	5		96906	MS35140-6
43	6	5975-00-878-3791	82370	A104
43	7		96906	MS90728-8
43	8		96906	MS35338-44
43	9		96906	MS15795-410

CROSS-REFERENCE INDEXES

FIGURE AND ITEM NUMBER INDEX

FIG.	ITEM	STOCK NUMBER	CAGEC	PART NUMBER
43	10		97403	13226E7922
43	11		97403	13225E3143
43	12		97403	13227E5689-1
43	13		97403	13227E5689-2
44			81337	5-13-4972
44	1		96906	MS35206-243
44	2		81337	5-13-4974
44	3		81337	5-13-4973
44	4		96906	MS27130-A13
44	5	6210-01-142-0431	72619	508-8738-504
44	6		4R884	HP11-51
44	7		52359	Q674L1181
44	8		81337	5-13-4976
45			81337	5-13-4830
45	1		81337	5-13-4728
45	2		81349	M6855/1-023211
45	3		96906	MS35425-74
45	4		96906	MS35338-46
45	5		96906	MS15795-413
45	6		81337	5-13-4730
45	7		81349	M6855/1-041211
45	8		81337	5-13-4729
45	9		96906	M535206-265
45	10		96906	MS15795-442
45	11		96906	MS35338-43
45	12		96906	MS35649-202
45	13		96906	MS90726-8
45	14		96906	MS35338-44
45	15		96906	MS15795-410
45	16		81337	5-4-4934
45	17		81337	5-4-4831
46	1		96906	MS35201-263
46	2		81337	5-13-4988
47			81337	5-13-5000
47	1		81348	GGG-W-641
47	2		96906	MS35206-245
47	3		81337	5-4-5106
47	4		96906	MS27130-A13
47	5		81337	5-13-4720
48			81337	5-13-5033
48	1		81337	5-4-3050
48	2		55719	P240
49			81337	5-13-4907
49	1		96906	5975-00-995-2168
49	2		97403	13227E5736
49	3		97403	13227E6253
49	4		97403	13227E
49	5		39428	7119K12
49	6		39428	7127K25
49	7		96906	MS35140-14
49	8		96906	MS35191-272

CROSS-REFERENCE INDEXES

FIGURE AND ITEM NUMBER INDEX

FIG.	ITEM	STOCK NUMBER	CAGEC	PART NUMBER
49	9		96906	MS35338-43
49	10		39428	7119K21
49	11		81337	5-13-5013
49	12		29215	JP2050-1
49	13		97403	13226E6991
49	14		81349	MIL-R-24243/6-A4 04H
49	15		79725	2151-2
49	16	5930-01-233-8370	74545	1221PL
49	17		81349	WC596/12-4
49	18		23828	1138V
49	19		81337	5-4-4984
49	20		96906	MS15795-408
49	21		03350	200
49	22		16327	2V637
49	23		96906	MS35191-277
49	24		76385	Z-4023
49	25	6240-01-024-6370	88204	52A/SS
49	26		90759	400
49	27		96906	MS35140-12
49	28		96906	MS27130-A29
49	29		81337	5-13-4980
49	30		81337	5-4-4928
49	31		28520	3210
50	1	5925-00-074-5750	56365	Q0B250
50	2	5925-00-785-4251	56365	Q0B340
50	3	5925-00-728-1289	56365	Q0B120
51	1		81337	5-13-4702
51	2		81349	MIL-R-24243/3-B4 04
51	3		96906	MS51939-1
51	4		97403	13226E6991
51	5		81337	5-4-4968
51	6		81337	5-4-4930
51	7		96906	MS90726-8
51	8		96906	MS35338-44
51	9		96906	MS15795-410
51	10		81337	5-4-4934
51	11		81337	5-4-4831
51	12		81337	5-13-4718
51	13		81337	5-13-4718
51	14		81337	5-13-4718
51	15		81337	5-13-4718
51	16		81337	5-13-4822
51	17		81337	5-13-4822
51	18		81337	5-13-4822
51	19		81337	5-13-4822
52	1		81348	WW-D, 1909, TY1
52	2		96906	MS35191-274
52	3		96906	MS35338-43
52	4		96906	MS15795-442

CROSS-REFERENCE INDEXES

FIGURE AND ITEM NUMBER INDEX

FIG.	ITEM	STOCK NUMBER	CAGEC	PART NUMBER
52	5		81337	5-4-4935
52	6		81337	5-4-4928
53	1		97403	13226E4508
53	2		96906	MS24693-280
53	3		81337	5-4-4935
53	4		81337	5-4-4928
54			81337	6-1-7543
54	1		96906	MS35425-70
54	2		96906	MS35338-44
54	3		96906	MS27183-10
54	4		81337	6-1-7543-2
54	5		81337	6-1-7543-8
54	6		96906	MS35190-287
54	7		81337	6-1-7543-5
54	8		81337	6-1-7543-4
54	9		96906	MS35191-291
54	10		81337	6-1-7543-1
54	11		81337	5-4-4934
54	12		81337	5-4-4831
54	13		81337	6-1-7543-6
54	14		81337	6-1-7543-7
54	15		96906	MS20470-AD6-8
54	16		81337	6-1-7543-3
55	1	4210-00-889-2491	58536	A-A-393
55	2		96906	MS35207-263
55	3		96906	MS35338-43
55	4		96906	MS15795-442
55	5		81337	5-4-4935
55	6		81337	5-4-4928
56		4240-01-226-1073	87327	SE-590
56	1		87327	G05-0461
56	2		87327	07-0065
56	3		87327	8-0116
56	4		87327	8-0234
56	5		87327	01-0632
56	6		87327	G24-0075
56	7		87327	8-0275
56	8		87327	20-0830
56	9		87327	05-0478
56	10		87327	31-0292
56	11		87327	20-0756
56	12		87327	RPG04-0438
56	13		87327	31-0356
56	14		87327	24-0244
56	15		87327	05-1668
56	16		87327	05-1671
56	17		87327	24-0246
56	18		87327	20-0783
56	19		87327	05-1669
56	20		87327	05-1670
56	21		87327	90-0111

CROSS-REFERENCE INDEXES

FIGURE AND ITEM NUMBER INDEX

FIG.	ITEM	STOCK NUMBER	CAGEC	PART NUMBER
56	22		87327	48-0097
56	23		87327	05-1672
56	24		87327	01-0681
56	25		87327	38-0202
56	26		87327	45-0071
56	27		87327	8-0137
56	28		87327	05-1768
56	29		87327	20-0830
56	30		87327	G20-0584
56	31		87327	G63-0022
56	32		96906	MS90728-64
56	33		96906	MS35338-46
56	34		96906	MS15795-413
56	35		81337	5-13-5056
56	36		81337	5-4-4968
56	37		81337	5-4-4930
56	38		96906	MS35191-272
56	39		96906	M527130-A26
57			81337	5-13-4969
57	1		81337	5-13-4946
57	2		96906	MS21316-13
57	3		81337	5-13-4881
57	4		81337	5-13-4964
57	5		96906	MS90727-163
57	6		96906	MS35338-50
57	7		96906	MS15795-420

Change 1 F-163/(F-164 blank)

APPENDIX G

ILLUSTRATED LIST OF MANUFACTURED ITEMS

THERE ARE NO MANUFACTURED PARTS LISTED FOR THE PRESS SECTION.

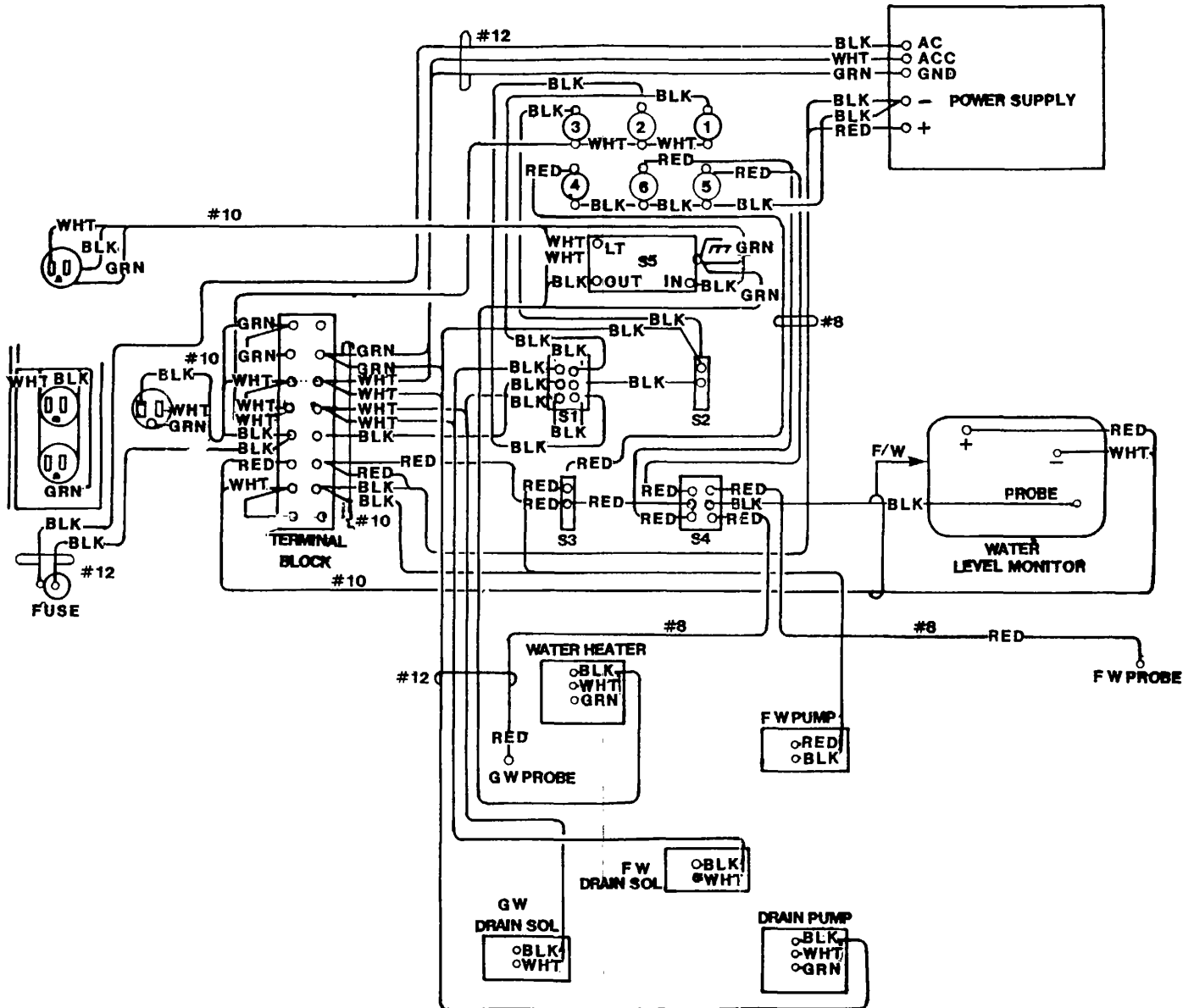

FO-1. Sink Assembly Wiring Diagram
FO-1

ALL WIRING IS AWG 20

RED
BLU
BLK
WHT

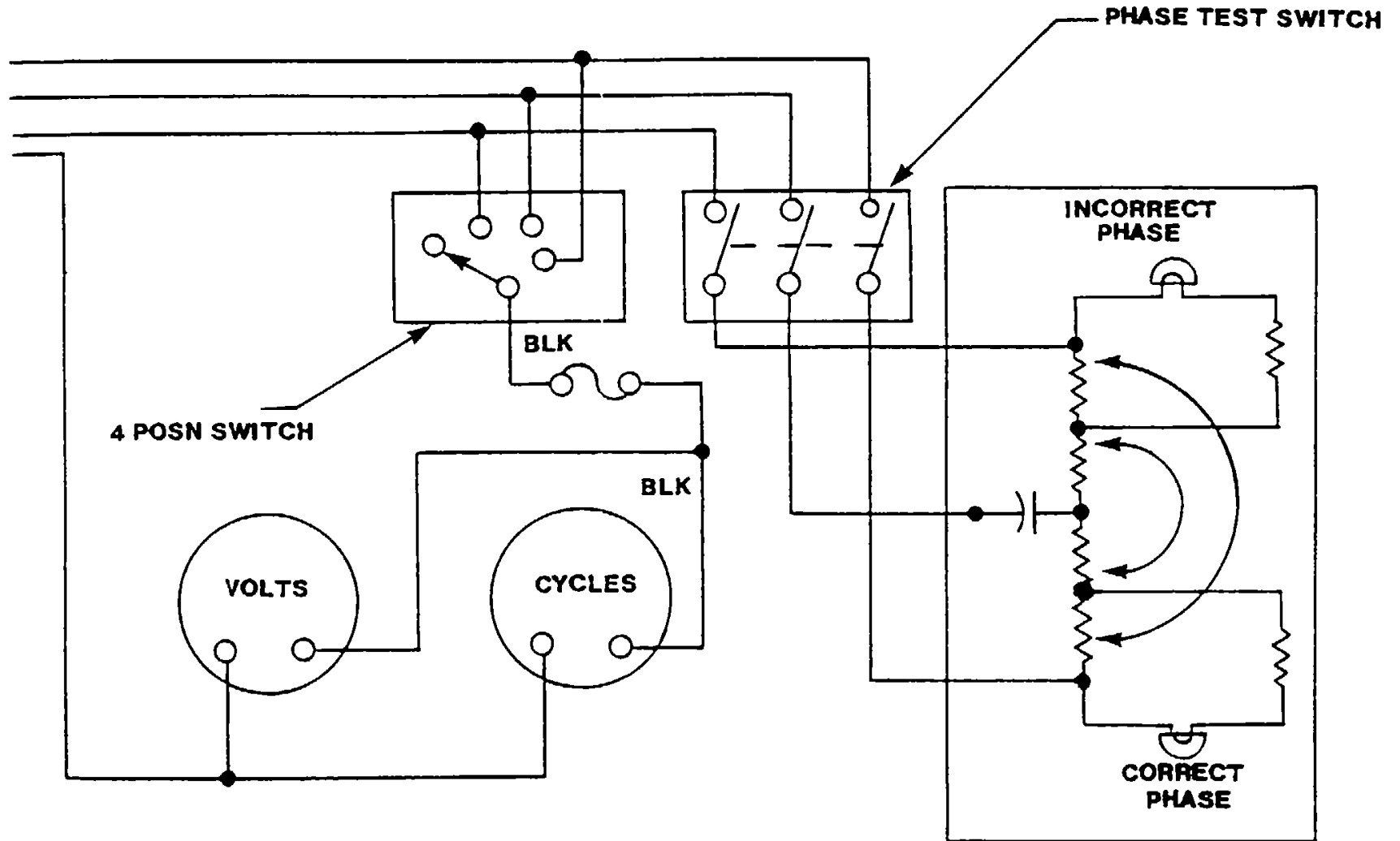

FO-2. Phase Monitor Meter Wiring Diagram
FO-2

By Order of the Secretary of the Army:

CARL E. VUONO
General, United States Army
Chief of Staff

Official:

THOMAS F. SIKORA
Brigadier General, United States Army
The Adjutant General

DISTRIBUTION:

To be distributed in accordance with DA Form 12-25E, (Qty rqr blk nos. 1237, 1238 and 1239), Operator, Unit and Direct Support Maintenance requirements for. Paper Conditioning Section, Topographic Support System, Model ADC-TSS-15 (TM 5-3610-252 Series)

RECOMMENDED CHANGES TO EQUIPMENT TECHNICAL PUBLICATIONS

 <p style="font-size: 1.2em; font-weight: bold;">SOMETHING WRONG WITH PUBLICATION</p>		FROM: (PRINT YOUR UNIT'S COMPLETE ADDRESS)	
		DATE SENT	
PUBLICATION NUMBER	PUBLICATION DATE	PUBLICATION TITLE	
BE EXACT PIN-POINT WHERE IT IS		IN THIS SPACE, TELL WHAT IS WRONG AND WHAT SHOULD BE DONE ABOUT IT.	
PAGE NO.	PARA-GRAPH		FIGURE NO.
PRINTED NAME, GRADE OR TITLE AND TELEPHONE NUMBER		SIGN HERE	

The Metric System and Equivalents

Linear Measure

1 centimeter = 10 millimeters = .39 inch
 1 decimeter = 10 centimeters = 3.94 inches
 1 meter = 10 decimeters = 39.37 inches
 1 dekameter = 10 meters = 32.8 feet
 1 hectometer = 10 dekameters = 328.08 feet
 1 kilometer = 10 hectometers = 3,280.8 feet

Weights

1 centigram = 10 milligrams = .15 grain
 1 decigram = 10 centigrams = 1.54 grains
 1 gram = 10 decigrams = .035 ounce
 1 decagram = 10 grams = .35 ounce
 1 hectogram = 10 decagrams = 3.52 ounces
 1 kilogram = 10 hectograms = 2.2 pounds
 1 quintal = 100 kilograms = 220.46 pounds
 1 metric ton = 10 quintals = 1.1 short tons

Liquid Measure

1 centiliter = 10 milliliters = .34 fl. ounce
 1 deciliter = 10 centiliters = 3.38 fl. ounces
 1 liter = 10 deciliters = 33.81 fl. ounces
 1 dekaliter = 10 liters = 2.64 gallons
 1 hectoliter = 10 dekaliters = 26.42 gallons
 1 kiloliter = 10 hectoliters = 264.18 gallons

Square Measure

1 sq. centimeter = 100 sq. millimeters = .155 sq. inch
 1 sq. decimeter = 100 sq. centimeters = 15.5 sq. inches
 1 sq. meter (centare) = 100 sq. decimeters = 10.76 sq. feet
 1 sq. dekameter (are) = 100 sq. meters = 1,076.4 sq. feet
 1 sq. hectometer (hectare) = 100 sq. dekameters = 2.47 acres
 1 sq. kilometer = 100 sq. hectometers = .386 sq. mile

Cubic Measure

1 cu. centimeter = 1000 cu. millimeters = .06 cu. inch
 1 cu. decimeter = 1000 cu. centimeters = 61.02 cu. inches
 1 cu. meter = 1000 cu. decimeters = 35.31 cu. feet

Approximate Conversion Factors

<i>To change</i>	<i>To</i>	<i>Multiply by</i>	<i>To change</i>	<i>To</i>	<i>Multiply by</i>
inches	centimeters	2.540	ounce-inches	Newton-meters	.007062
feet	meters	.305	centimeters	inches	.394
yards	meters	.914	meters	feet	3.280
miles	kilometers	1.609	meters	yards	1.094
square inches	square centimeters	6.451	kilometers	miles	.621
square feet	square meters	.093	square centimeters	square inches	.155
square yards	square meters	.836	square meters	square feet	10.764
square miles	square kilometers	2.590	square meters	square yards	1.196
acres	square hectometers	.405	square kilometers	square miles	.386
cubic feet	cubic meters	.028	square hectometers	acres	2.471
cubic yards	cubic meters	.765	cubic meters	cubic feet	35.315
fluid ounces	milliliters	29.573	cubic meters	cubic yards	1.308
pints	liters	.473	milliliters	fluid ounces	.034
quarts	liters	.946	liters	pints	2.113
gallons	liters	3.785	liters	quarts	1.057
ounces	grams	28.349	liters	gallons	.264
pounds	kilograms	.454	grams	ounces	.035
short tons	metric tons	.907	kilograms	pounds	2.205
pound-feet	Newton-meters	1.356	metric tons	short tons	1.102
pound-inches	Newton-meters	.11296			

Temperature (Exact)

°F	Fahrenheit temperature	5/9 (after subtracting 32)	Celsius temperature	°C
----	------------------------	----------------------------	---------------------	----

PIN: 045062-002